

## CHAPTER 9: CFS III MAINTENANCE

### 9.1 Description

The UNICUS 4i containment fill stations are designed and have been tested to offer the operator protection against the explosive force and resulting shrapnel should a cylinder fail during the filling operation.



### WARNING

If a cylinder fails during a filling operation, the Containment Fill Station must be considered damaged beyond repair and destroyed to prevent its ever being used again.

The fill station features fill hoses complete with bleed valves and SCBA fill adapters of choice, mechanical door interlock, and a fill control panel with individual pressure gauges.

### 9.2 Fill Station Air Flow

Refer to the Pneumatic Diagram DGM-1137, after the Appendix.

From the air inlet, compressed air flows to the Fill Pressure Regulator (R1) where the desired bottle fill pressure is set and maintained. The Regulator Inlet Pressure Gauge (P1) indicates the supply pressure to the Regulator (R1). The Regulator Outlet Pressure Gauge (P2) indicates this regulated pressure. The Fill Pressure Relief Valve (RV1) ensures against overfilling the bottle if the Fill Pressure Regulator (R1) fails.

The Door Interlock Valves (V1) are operated when the door is closed and the lock bar is in the down and locked position. This prevents the filling of bottles until the door is properly closed and locked.

When the Mechanical Door Interlock Valves (V1) are operated it allows compressed air to flow from the outlet of the Fill Pressure Regulator (R1) to the Fill Hoses (H1) via the Fill Hose Shut Off Valve (V2).

Fill Pressure Gauge (P3) is used to monitor the progress of the recharging operation.

The operator closes the Fill Hose Shut Off Valve (V2) when the bottle reaches the desired pressure, stopping the flow of air to the bottle.

The optional Fill Pressure Relief Valves (RV2) can be used to allow multiple fill pressures in the same CFS II.

Should the operator not close the Fill Hose Shut Off Valve (V2) when the bottle is full, the Relief Valve (RV2) will open, venting excess pressure.

When the recharging operation is complete the operator presses down on the Door Handle and opens the door which disengages the Mechanical Door Interlock Valves (V1) eliminating the possibility of the flow of compressed air to the bottles.

Before the bottles can be removed from the fill station the bottle valve must be closed and the pressure remaining in the Fill Hoses (H1) bled off by opening the Drain/Bleed Valve (V3).

### 9.3 Maintenance

#### 9.3.1 General Maintenance

Develop a regular program of visual inspection, looking for clogged drains and broken or missing parts.

### 9.3.2 Nonadjustable Valves

The condensate drain valve, bleed valve and check valves are not adjustable. The condensate drain valve and bleed valve have seats and seals which should be replaced if the valve leaks. Check valves are not adjustable or repairable and must be replaced if they malfunction.

### 9.3.3 Pressure Gauges

Observe the pressure gauges daily. If the readings of any of the gauges seem to be incorrect, bleed off all system pressure. Check that the gauges correctly read zero then reapply pressure to the system. If the reading is still incorrect contact Bauer Compressors for service. All broken or damaged gauges must be replaced immediately.

### 9.3.4 Safety Valves



The safety valve must be checked periodically for proper functioning.

1. Operate the compressor with the shut-off valve closed until the safety valve vents.
2. Note the pressure registered on the pressure gauge.

The safety valve is adjusted at the factory to the required pressure and does not normally require maintenance or readjustment. In case readjustment does become necessary, have the safety valve adjusted by a Bauer qualified technician (contact the Bauer service department for details) or return the valve to the factory.

### 9.3.5 Pneumatic Connections



#### **WARNING**

Maintenance of pipe and tubing connections should not be attempted while the unit is under pressure. Serious injury or equipment damage will result if the connection fails or is loosened.

After determining that a pneumatic connection is leaking, Relieve compressed air pressure and tighten just firmly enough so that leakage is stopped (finger tight plus up to an additional 1/2 turn as necessary). Please note that the compression type coupling fittings are capable of exerting extreme force on the tubing and should not be tightened more than is required to seal the joint. To improve the sealing of the pipe connections and to facilitate installation, the following should be observed:

Apply a thin layer of Never-Seez® NSW1 or equivalent on the outside of the ferrule during assembly.

Lubricate the threads of the connector with Never-Seez® NSW1 or a similar PTFE base lubricant to facilitate future disassembly.

### 9.3.6 Bearings for Bottle Door Pivot

There is no need for relubrication under normal conditions.

If the setscrews should become loose, tighten as follows:

Setscrew diameter	Hex size	Recommended torque (inch lbs)
5/16"	5/32"	165

### 9.3.7 Pressure Hoses

The hoses should be inspected periodically for wear and damage. If a hose is worn or damaged, remove and replace it.

### 9.3.8 Door Gas Spring

A special tool, Spring Holder, TOO-0020 is required.

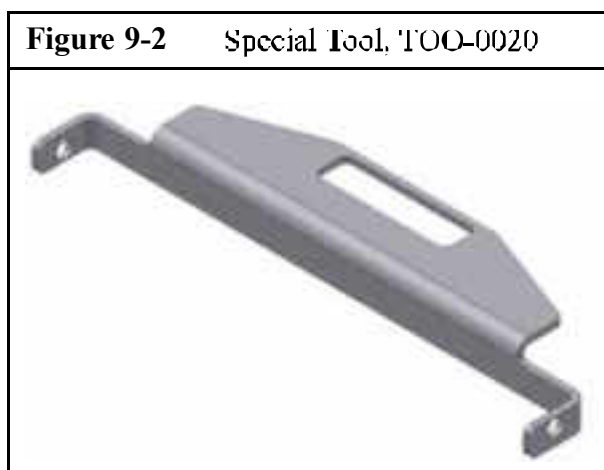

To remove and install a Door Gas Spring proceed as follows:

1. Place a piece of cardboard in the bottom of the door opening to protect the finish of the Door and Enclosure.
2. Remove the Door Stop and Mount from the inside rear of the Enclosure.
3. Lower the Door until it touches the cardboard.
4. Install the Spring Holder, TOO-0020 and raise the Door until the Holder is holding the Door Gas Spring.
5. Remove the nut on the lower mounting stud and remove the Door Gas Spring from the Door.
6. Lower the Door and allow it to rest on the cardboard.
7. Remove the nut on the upper spring mounting stud and remove the Door Gas Spring.
8. Install the replacement Door Gas Spring in the reverse order.

**9.4 Replacement Parts List**

**9.4.1 CFS III Assemblies**

**Figure 9-3** CFS III Assembly



Item	Qty	Part No.	Description	Notes
1	3	HOL-0124	Bottle Holder	
2	1	DOR-0114	Door	
3	3	HOS-0115	Fill Whip	
4	1	HAN-0078	Handle	

1. Replaced by ASY-8067 if unit has RFID option

**Figure 9-4** Fil. Whips & Brackets

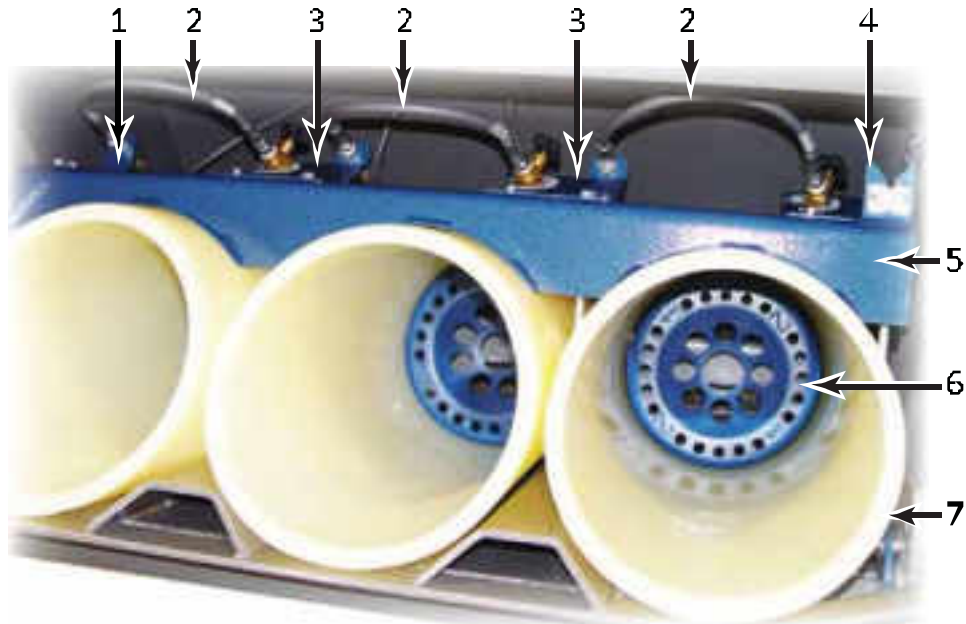

Item	Qty	Part No.	Description	Notes
1	1	MTS-0316	Hose Bracket	
2	3	HIOS-0145	Fill Whip	1 per fill position
3	2	MTS-0315	Hose Bracket with Whip Holder	
4	1	HIOL-0077	Fill Whip Holder with Door Interlock Actuator	
with	1	PLT-0396	Plastic Wear Plate	
5	1	CMP-0144	Bottle Holder Bracket	CFS III - 1
6	3	SPC-0118	Bottle Riser	1 per fill position
7	3	HIOL-0124 <sup>1</sup>	Bottle Holder	1 per fill position

<sup>1</sup>. Replaced by ASY-8067 if unit has RFID option

**Figure 9-5** CFS III Door Lock Assembly

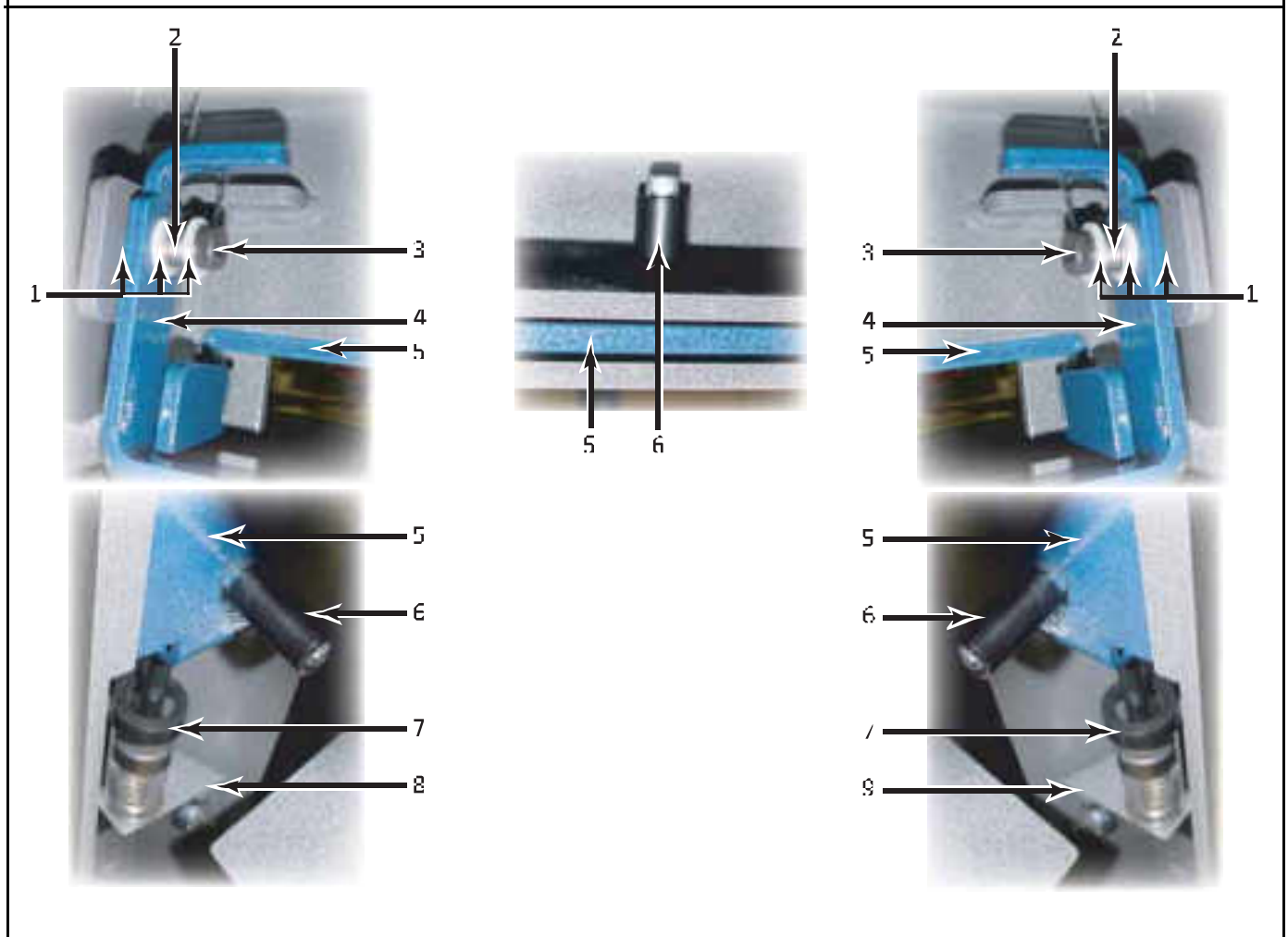

Item	Qty	Part No.	Description	Notes
1	6	—	Nylon Flat Washer	3/8"
2	2	SPG-0052	Torsion Spring	
3	2	—	Socket Head Shoulder Screw	3/8" x 7/8"
4	2	LCII-0048	Latch	
5	1	LCII-0090	Door Lock	
6	3	BUS-0153	Bushing	
7	2	CYL-0059	Damper	
8	1	BRK-0673	Cylinder Bracket	Right
9	1	BRK-0672	Cylinder Bracket	Left

**Figure 9-6** Door Handle, Pivot and Bracket

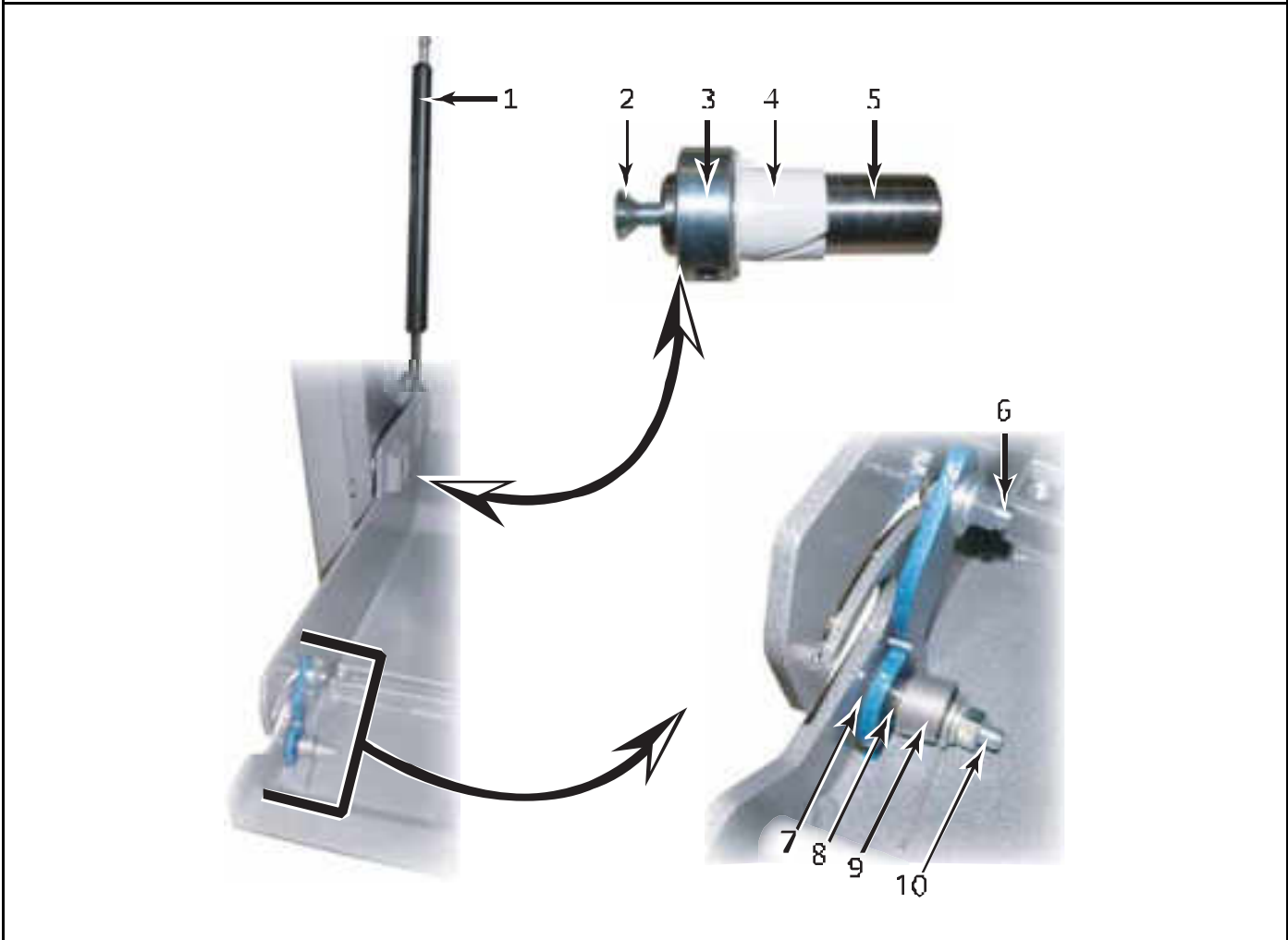

Item	Qty	Part No.	Description	Notes
1	1	SPG-0078	Gas Spring	
2	2		Flat Head Socket Cap Screw	5 16x18 x 3 4" UNC
3	2	CLR-0001	Collar	
4	2	BUS-0121	Bushing	
5	2	PIN-0047	Pin	
6	2		Socket: Head Cap Screw	3 8-16 x 1" UNC
7	2		Washer, Nylon	5 8"
8	2	BUS-0122	Bushing	
9	1	SPG-0054	Spring	Right Side
NS	1	SPG-0053	Spring	Left Side
10	2		Socket: Head Cap Screw	3 8-16 x 2" UNC

**Figure 9-7** CFS III Door Interlock

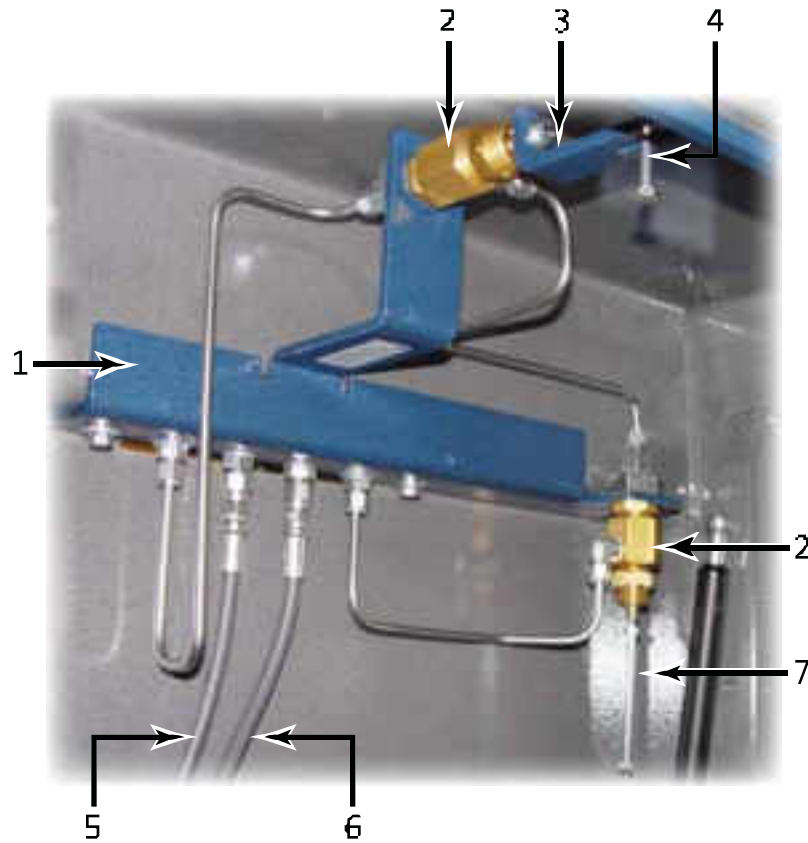

Item	Qty	Part No.	Description	Notes
1	1	BRK-0671	Bracket	
2	2	VAL-0130	Interlock Valve	
3	1	LEV-0025	Lever	
4	1	SCR-0078	Hex Head Cap Screw	1/2-20 x 4" UNC
5	1	HOS-0147	Hose, Left	
6	2	HOS-0146	Hose	
7	1	—	Hex Head Cap Screw	1/2-20 x 4 1/2" UNC



9.5 Fill Hose Assemblies

Figure 9-8 Standard Fill Hose Assemblies

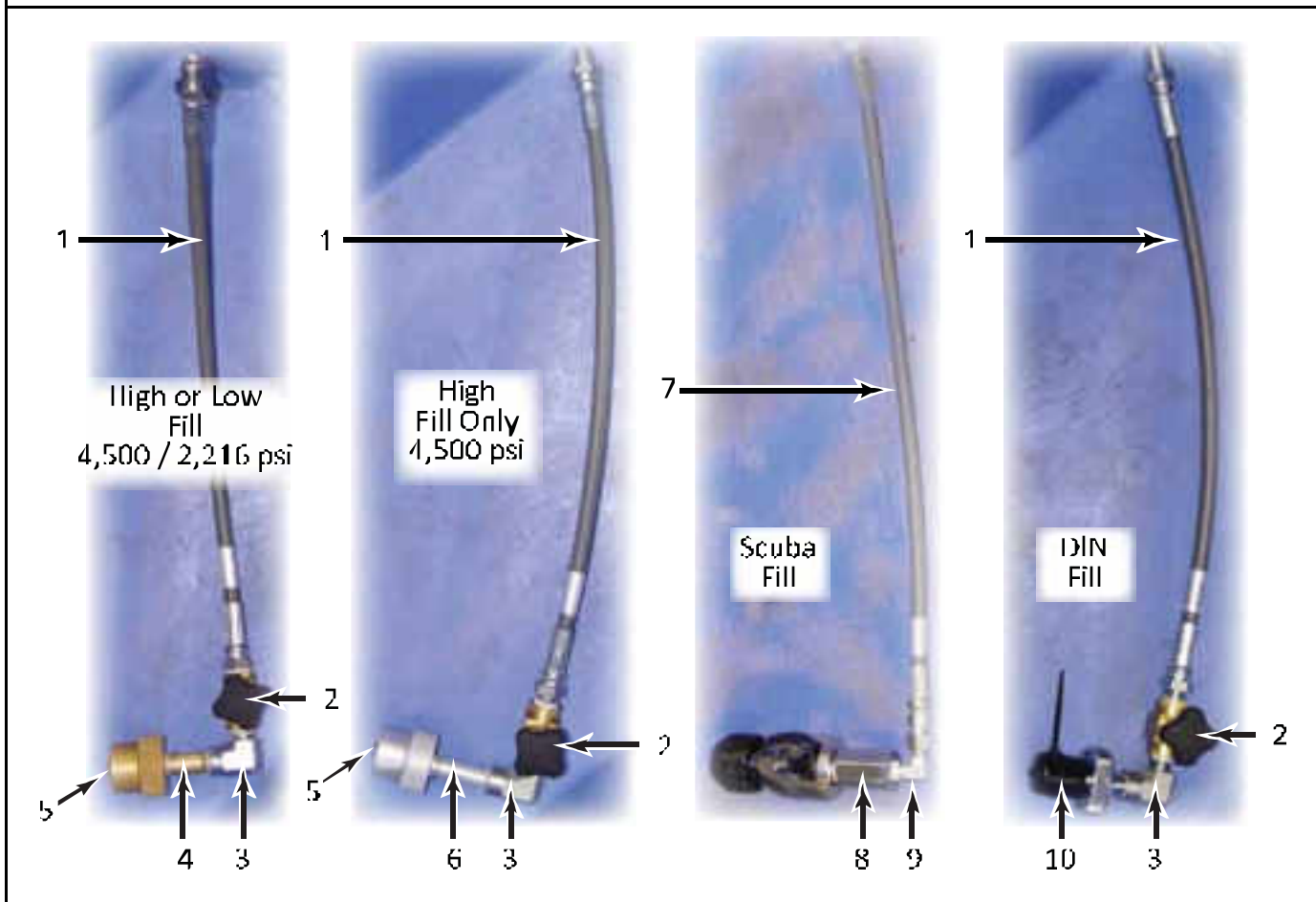

Item	Qty	Part No.	Description	Notes
1	1	HOS-0145	Fill Hose	25"
2	1	065126	Bleed Valve	
3	1	ELL-0018	Elbow	
4	1	ADP-0112	Adapter	4,500 / 2,216 psi Cylinder
5	1	N04483	O-ring	
6	1	ADP-0113	Adapter	4,500 psi Cylinder
7	1	HOS-0150	Fill Hose, Scuba	27"
8	1	ELL-0031	Elbow	<i>scuba fill only</i>
9	1	YOK-0001	Scuba Fill Yoke with Bleed Valve	
10	1	ADP-0207	DIN Fill Adapter	4,350 psig (300 bar)



**Figure 9-9** Fill Whips with Options

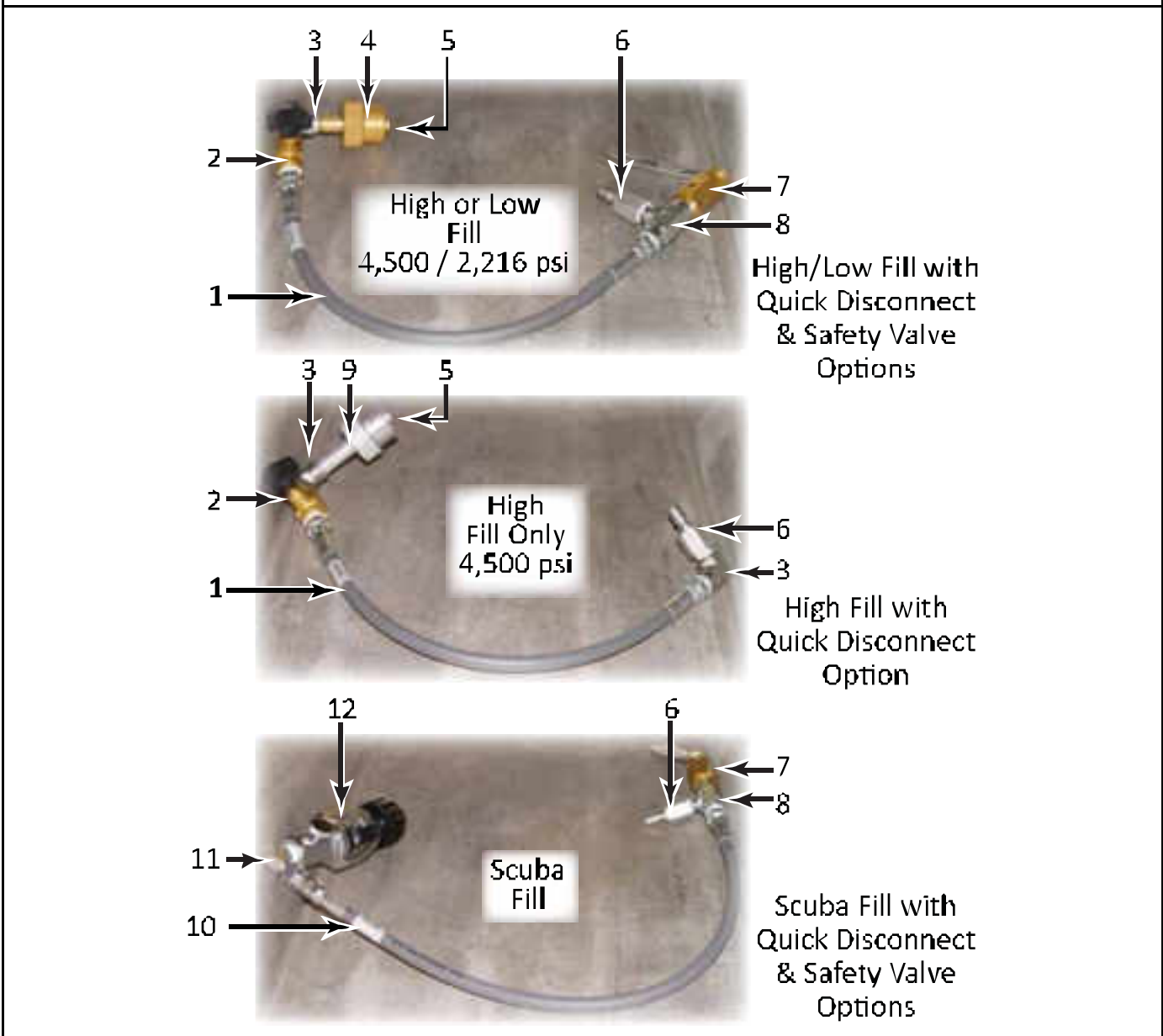

Item	Qty	Part No.	Description	Notes
1	1	HOS-0145	Fill Hose	
2	1	065126	Bleed Valve	
3	-	ELT-0018	Elbow	
4	1	ADP-0112	Adapter	4,500 / 2,216 psi Cylinder
5	1	N04483	O-ring	
6	1	CON-0223	Quick Disconnect	
7	1	VAL-0169	Safety Valve	
8	1	TUE-0014	Tee	

**MNL-0021****Figure 9-9 (cont.)****Standard Fill Hose Assemblies**

<b>Item</b>	<b>Qty</b>	<b>Part No.</b>	<b>Description</b>	<b>Notes</b>
9	1	ADP-0113	Adapter	4,500 psi Cylinder
10	1	HOS-0150	Fill Hose, Scuba	
11	1	ELL-0031	Elbow	
12	1	YOK-0001	Scuba Fill Yoke with Bleed Valve	

**CHAPTER 10: UNICUS III HP AIR STORAGE**

**10.1 Bottle Specifications**

Storage systems are available to meet the code requirements of either the United Nations (UN) model regulations (ISO 9809-PART 2) or the American Society of Mechanical Engineers (ASME). Standard operating temperature range for storage systems is -20 to 150 °F. Designs to -40 °F are an available option.

**10.1.1 ISO/UN; ISO 9809-PART2 / United Nations**

These vessels are approved by the US Department of Transportation. The cylinders must be equipped with the proper cylinder valve and CGA recommended outlet. Retest period for ISO UN cylinders is mandatory every ten (10) years.

Bauer can supply 5,000 psig and 6,000 psig ISO/UN systems complete with interpiping, pressure gauges, cylinder valves and check valve. Optional mounting racks are available.

Vessel	ISO / UN		
	4,500 psig	5,000 psig	6,000 psig
Material	Lightweight Steel Alloy		
Volume	437 cf (@ 4,500 psig)	472 cf (@ 5,000 psig)	510 cf (@ 6,000 psig)
Working Pressure	4,500 psig	5,000 psig	6,000 psig
Test Pressure	6,750 psig	7,500 psig	9,000 psig
Diameter	9.41"		
Height	55" with Valve	56" with Valve	
Weight	155 lbs	170 lbs	195 lbs
Cylinder Valve	Dual-Out 1/2" NPTF	CGA 347	Dual-Out 1/2" NPTF
Finish	Primer and Topcoat		

**10.1.2 ASME; American Society of Mechanical Engineers**

Each vessel should have a shut-off valve and an A.S.M.E. approved safety valve. Vessels with working pressures of 5,000 psig, have a safety factor of 4 to 1. Vessels with working pressures of 6,000 psig, have a safety factor of 3 to 1. Bauer can supply 5,000 psig and 6,000 psig A.S.M.E. storage systems complete with interpiping, pressure gauges, safety valves, cylinder valves and check valves. Optional mounting racks are available.

Vessel	ASME	
	5,250 psig	6,600 psig
<b>Material</b>	Steel ASME SA 372 Class V Type A AT51 4130	
<b>Volume</b>	424 cf @ 5,000 psig	481 cf @ 6,000 psig
<b>Working Pressure</b>	5,000 psig	6,000 psig
<b>Test Pressure</b>	7,875 psig	10,500 psig
<b>Diameter</b>	9.58"	
<b>Height</b>	55" without Valve	
<b>Weight</b>	400 lbs	
<b>Cylinder Valve</b>	Standard Valve Supplied	
<b>Finish</b>	Primer and Topcoat	

## 10.2 Description and Maintenance

### 10.2.1 Description

The air storage system consists of one (or more) D.O.T. or A.S.M.E. storage vessels with line valves, safety valves, interconnecting tubing, pressure gauges, check valves and mounting clamps.

D.O.T. vessels are approved by the Department of Transportation for portable usage. D.O.T. systems are available at 5,000 psi and 6,000 psi.

A.S.M.E. vessels conform to the American Society of Mechanical Engineers codes for permanent installation. These vessels have working pressures of 5000 psig, with a safety factor of 4 to 1; and 6,000 psig, with a safety factor of 3 to 1. A safety device is provided on each vessel to protect against excess pressure. It is preset at the factory and sealed. It should not be adjusted.

**Figure 10-1 UNICUS III Storage Systems**

## 10.2.2 Maintenance

### 10.2.2.1 Storage Bottles

All storage bottles should be visually inspected internally every year. Every five (5) years, D.O.T. bottles must be hydro-tested.

Check local and state regulations regarding testing of ASME or D.O.T. bottles. Some states require an annual visual inspection, and hydro-testing requirements also differ from state to state.

### 10.2.2.2 Pressure Gauges

1. Observe the pressure gauges daily.
2. If the readings of any of the gauges seem to be incorrect, bleed off all system pressure.
3. Then, remove the gauge and check for wear and tear, accuracy and proper functioning by comparing it to a precision test gauge or a dead weight tester.
4. Replace all broken or damaged gauges immediately.

### 10.2.2.3 Tube Connections

Pipe connections (swivel nuts): Tighten just firmly enough so that leakage is stopped (finger tight plus up to an additional 1/2 turn as necessary). Please note that the compression type coupling fittings are capable of exerting extreme force on the tubing and should not be tightened more than is required to seal the joint.

To improve the sealing of the pipe connections and to facilitate installation apply a thin layer of Never-See<sup>®</sup> NSWT or a similar PTFE base lubricant to the ferrule and the threads of the connector to facilitate future disassembly.

### 10.2.2.4 Safety Valve

**Figure 10-2** Safety Valve; VAL-0022



- Develop a regular program of visual inspection, looking for clogged drains and discharge pipe, dirt build-up in and around the valve seat, and broken or missing parts.
- Avoid excessive operation of the safety valve, as even one opening can provide a means for leakage. Safety valves should be operated only often enough to assure that they are in good working order.
- Do not paint, oil or otherwise cover any interior or working parts of any safety valve. They do not require any lubrication or protective coating to work properly.

### 10.2.2.5 Pressure Hoses

The hoses should be inspected periodically for wear and damage. If a hose is worn or damaged, remove and replace it.



### 10.3 Autocascade System

#### 10.3.1 General

The auto cascade system utilizes Siemens PLC technology to open and close valves from up to 4 storage banks. The auto cascade system opens storage banks as needed and allows the compressor to refill the depleted storage banks in a systematic order. The system replaces what previously required a human operator. It monitors the storage banks and open and closes the valves as needed, all automatically.

This section gives an overview of how the autocascade system functions.



**Figure 10-3** Autocascade System

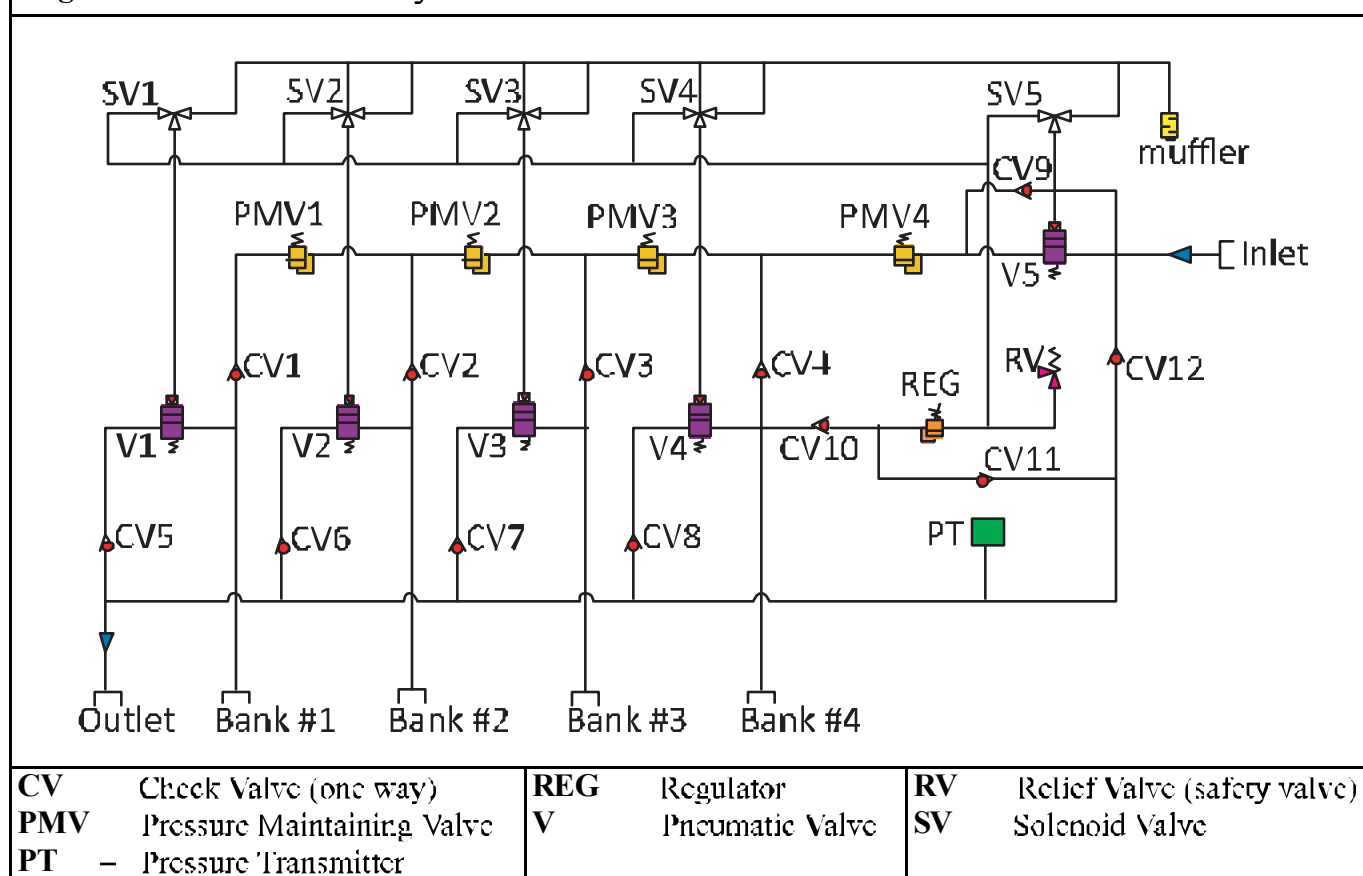

### **10.3.2 Electrical**

Siemens electronics are used for this application. The PLC monitors the Pressure Transmitter continuously and opens solenoid valves 1-5 as needed.

### **10.3.3 Filling the Storage Banks**

When the compressor begins delivering purified compressed air it is applied to the inlet of the first priority valve (5). It opens and begins filling the 1st storage bank (9). As this storage bank (9) fills, the pressure is applied to the inlet port of the 2nd priority valve (6). When the actuation pressure is reached, the 2nd priority valve opens and fills the 2nd storage bank (10). This same sequence of operations continues and allows the 3rd storage bank (11) to be filled by the 3rd priority valve (7) and 4th storage bank (12) to be filled by 4th priority valve (8). The actuation point of the priority valves is approximately 1,000 psi less than the cut off pressure of the compressors final pressure switch thus ensuring the storage banks are individually filled to the actuation pressure. Once all the storage banks are at this pressure the compressor then fills all the storage banks simultaneously to the compressor final pressure. When this pressure is reached the storage banks are fully charged and compressor shuts down.

### **10.3.4 Filling Bottles from the Storage Banks**

When the outlet is used for filling, the compressed air is drawn from the 4th storage bank. When the difference on the control ports of the 4th sequence valve falls below approximately 200 psi the valve is forced to the other position and compressed air begins flowing from the 3rd storage bank. The 3rd sequence valve controls the flow until the pressure differential is again less than 200 psi when it is forced to the other position and filling begins from the 2nd storage bank. Once again when the pressure differential drops below 200 psi the sequence valve moves to the other position and air flows from the 1st storage bank. When the pressure in the 1st storage bank drops to the cut on pressure of the compressor, the compressor starts and provides air directly to the outlet.

### **10.3.5 Manual Bypass**

The autocascade is equipped with a manual bypass in case of power failure or if the operator wishes to utilize the CFS straight from the storage cylinders and not using the compressor. The top gauge tells the pressure in the storage tanks. The valve on top must be opened by turning clockwise. The bottom valve is the regulator, used to set the pressure to fill the cylinders in the CFS. The bottom gauge shows the pressure going to the CFS.

---







**CHAPTER 11:APPENDIX****11.1 Safety****11.1.1 General Safety Precautions**

- Read the operating manual before installing or operating this compressor unit. Follow appropriate handling, operation and maintenance procedures from the very beginning. The maintenance schedule contains measures required to keep this compressor unit in good condition. Maintenance is simple, but must be executed regularly to achieve safe operation, maximum efficiency and long service life.
- We recommend that all maintenance work be recorded in a service book, showing the date and details of the work carried out. This will help to avoid expensive repair caused by missed maintenance work. If it is necessary to make a Claim against the warranty, it will help to have proof that regular maintenance has been carried out and that the damage has not been caused by insufficient maintenance.
- This compressor unit must be installed, operated, maintained and repaired only by BAUER authorized, trained and qualified personnel. Information on BAUER training and becoming BAUER authorized can be accessed at (757)858-6006 or [productsupport@bauercomp.com](mailto:productsupport@bauercomp.com).
- Consult and follow all OSHA, NEMA, ASME and local regulations, laws and codes covering the installation and operation of this compressor and accessories before operating the unit.
- Do not operate this unit in excess of its rated capacity, speed, pressure, temperature, or otherwise than in accordance with the instructions contained in this manual. Operation of this unit in excess of the conditions set forth in this manual will subject the unit to limits which it may not be designed to withstand.
- Keep safety guards in place.
- Do not modify the compressor or its systems.
- Do not wear loose clothing around machinery. Loose clothing, neckties, rings, wrists watches, bracelets, hand tags, etc. are potential hazards.
- Provide adequate fire protection. Make sure fire extinguishers are accessible. Select alternate routes of escape and post such routes.
- Make sure you are equipped with all required safety equipment; hearing protection, safety glasses, hard hats, safety shoes and fire extinguisher.
- Visually inspect the unit before starting. Remove and or replace any loose or broken components, tools, valves, missing equipment, etc.
- Do not tamper with, modify, or bypass safety and shutdown equipment.
- Do not tighten or adjust fittings or connections under pressure.
- The use of plastic pipe or rubber hose in place of steel tube or iron pipe, soldered joints or failure to ensure system compatibility of flex joints and flexible hose can result in mechanical failure, property damage, and serious injury or death.
- The use of plastic or nonmetallic bowls on line filters without metal guards can be dangerous.
- Replace damaged fan blades promptly. Fan assemblies must remain in proper balance. An unbalanced fan can fly apart and create an extremely dangerous condition.

- Allow the compressor to cool before servicing. Whenever the compressor is shut down and overheating is suspected, a minimum period of 15 minutes must elapse before opening the crankcase. Premature opening of the crankcase of an overheated unit can result in an explosion.
- Incorrect placement of the inlet and pressure valves in a compressor cylinder head can cause an extremely dangerous condition. Refer to the appropriate section of this manual before installing or replacing valves.
- Before doing any work involving maintenance or adjustment, be sure the electrical supply has been disconnected, and the complete compressor system has been vented of all internal pressure. Failure to follow these warnings may result in an accident causing personal injury and/or property damage.
- Before working on the electrical system, be sure to disconnect the electrical supply from the system at the circuit breaker or other manual disconnect. Do not rely on the ON/OFF switch to disconnect the electrical supply.
- Installer must provide an earth ground and maintain proper clearance for all electrical components.
- All electrical installation must be in accordance with recognized national, state, and local electrical codes.
- Do not use gasoline, diesel fuel or other flammable products as a cleaning solution.
- A compressor which has been used for gas service is unsuitable for Gas applications. Should the purchaser and/or user proceed to use the compressor for Gas service after it has been used for gas, the purchaser and/or user assumes all liability resulting therefrom without any responsibility being assumed by Bauer Compressors, Inc. The purchaser is urged to include the above provision in any agreement for resale of this compressor.
- The use of repair parts other than those listed in this manual or purchased from Bauer Compressors, Inc. may create unsafe conditions over which Bauer has no control. Such unsafe conditions can lead to accidents that may be life-threatening, cause substantial bodily injury, and/or result in damage to the equipment. Therefore, Bauer Compressors, Inc. can bear no responsibility for equipment in which non-approved repair parts are installed.

### 11.1.2 Safety Warning Labels

Notes, labels and warning signs are displayed on the compressor unit according to model, application or equipment and may include any of the following.

	<p><b>HOT SURFACES DO NOT TOUCH!</b> Danger of burning if cylinders, cylinder heads, or pressure lines of individual compressor stages are touched.</p>
	<p><b>HIGH VOLTAGE!</b> Life threatening danger of electrical shock. Maintenance work on electric units or operating equipment should be carried out by a qualified electrician or by a person supervised by a qualified electrician according to electrical regulations.</p>
	<p><b>AUTOMATIC COMPRESSOR CONTROL UNIT MAY START WITHOUT WARNING!</b> Before carrying out maintenance and repGas work, switch off at the main switch and ensure the unit will not restart.</p>
	<p><b>THE INSTRUCTIONS MUST BE READ BEFORE OPERATING THE UNIT!</b> The instruction manual and all other applicable instructions, regulations, etc. must be read and understood by the operating personnel before using the machine.</p>
	<p><b>HEARING PROTECTION MUST BE WORN!</b> Hearing protectors must be worn when working on a machine which is running.</p>
	<p><b>DIRECTION OF ROTATION!</b> When switching on the machine, check the arrow on the compressor to ensure correct direction of rotation by the drive motor.</p>

## 11.2 Unpacking, Handling and Installation

### 11.2.1 Unpacking and Handling

This compressor unit is packaged according to the requirements for shipping via the requested type of carrier service. It is possible that the compressor unit could have been damaged during shipping. For this reason, we urge you to thoroughly examine the unit for possible damage and report any such damage to the shipping company immediately.

Care must be taken in unpacking the compressor unit. Serious damage could result by not checking for clearance between the item being unpacked and the packaging to be removed.

Handling of the unpacked unit should be performed using only the following devices. See Figure 11-1.

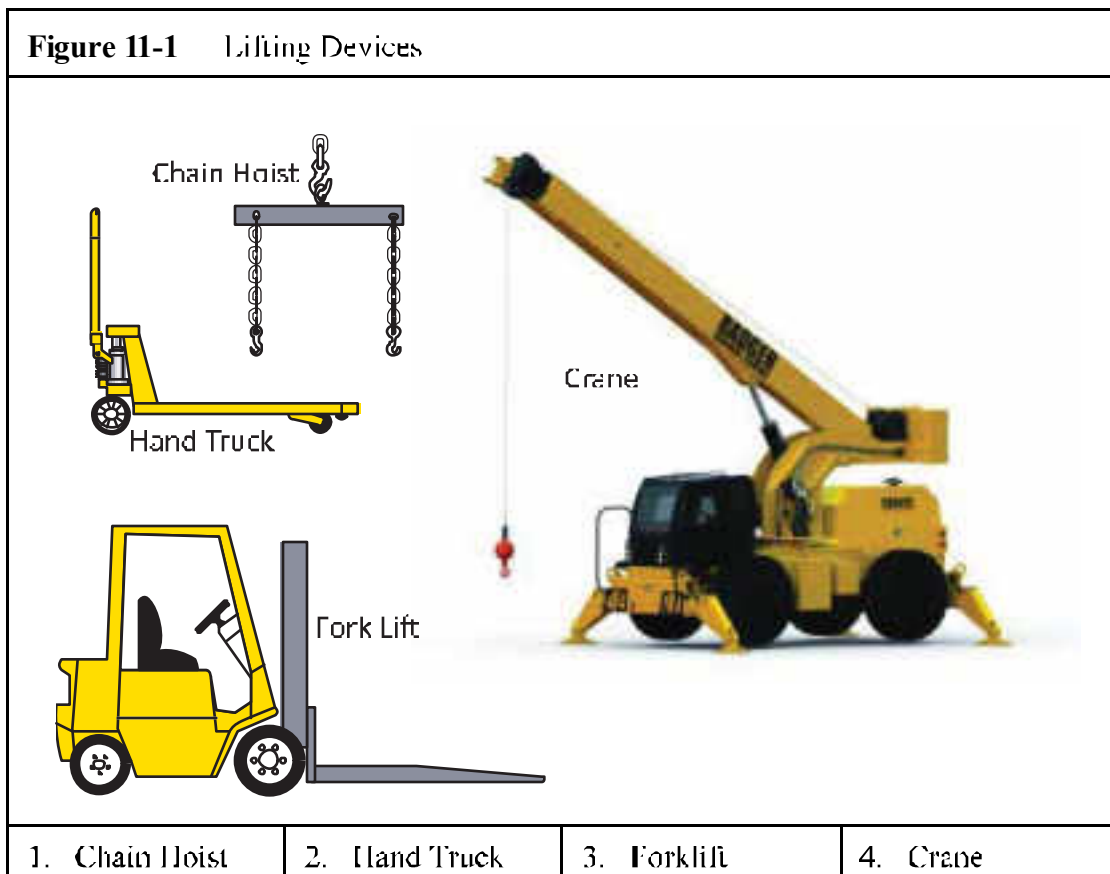

### WARNING

Be sure the lifting devices are capable of handling the weight of the unit (see Paragraph 1.4 for the approximate weight of the unit). Before lifting the unit, secure all loose or swinging parts to keep them from moving. Stay clear of lifted load.

The compressor unit may be furnished with one or more shipping braces for shipping and handling only. After installation and before operation, these braces must be removed entirely. Under no circumstances should the braces remain installed during operation or the manufacturer's warranty for the compressor unit will be voided. All braces are tagged and labeled.

## 11.2.2 Installation of the Compressor Unit

### 11.2.2.1 General

The floor site must be capable of supporting the weight of the unit. Secure the compressor unit to the floor using ½" lag bolts. Position the unit so that it is level. Permissible inclination of the compressor unit is listed in Paragraph 1.4.



### CAUTION

The inclination values listed in Paragraph 1.4 are valid only if the oil level of the compressor is level with but does not exceed the upper mark of the oil dipstick or oil level sight glass.

If equipped with machine leveling feet, ensure the unit is leveled to prevent movement when operating. Raise the unit with a forklift or crane to raise the unit at the leveling foot. Loosen the locking nut and turn the leveling bolt clockwise to desired height. Lock the leveling foot in place with the provided hex nut once the desired height is achieved. Set the unit back down on the floor and check adjusted height. If further adjustment is needed repeat.

**Figure 11-2** Leveling Feet

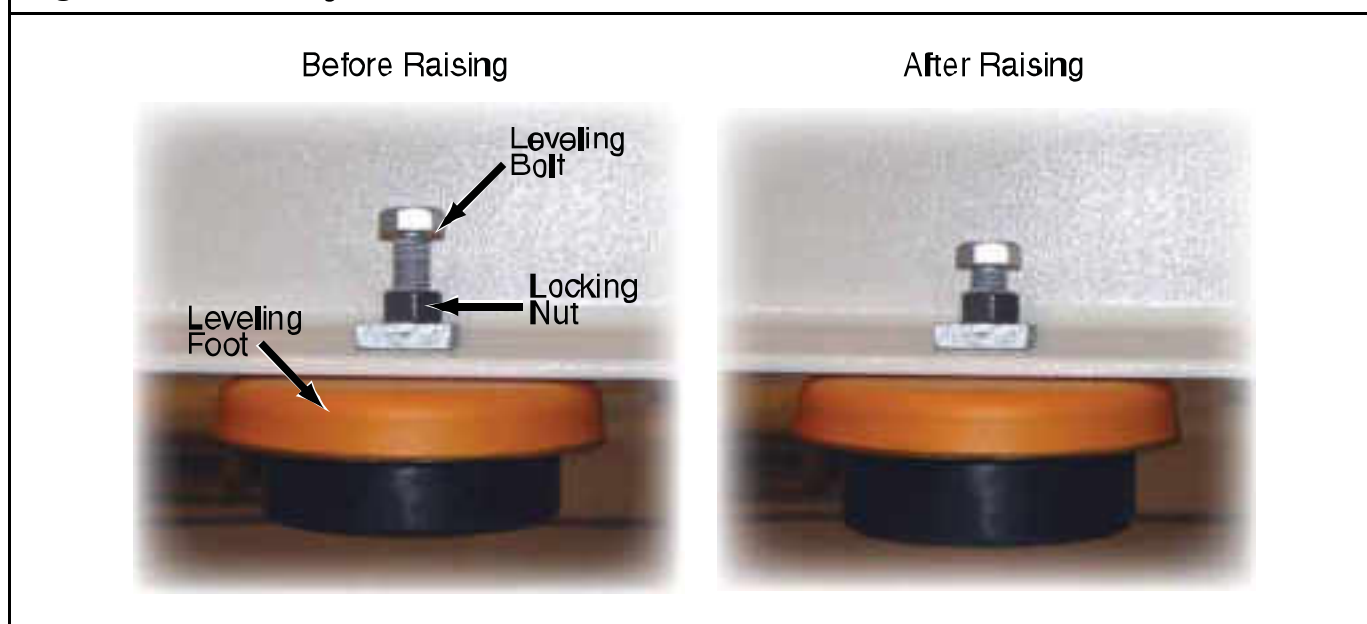

Ensure that the compressor Gas intake is supplied with fresh Gas. The intake Gas must not contain any exhaust fumes or flammable vapors such as paint solvents, which may cause an internal fire. Make sure that the intake Gas is unobstructed and moisture in the intake Gas is kept to a minimum. It is important that units draw in clean Gas. The quality of the incoming Gas determines the quality of the compressed Gas. This is important even for industrial Gas, as any incoming fumes will also be compressed and will increase the toxicity to anyone working with the compressed Gas.

If a remote control is provided, the unit must be equipped with a clearly visible plate warning the possibility of the unit starting. As an additional measure, anyone starting the unit by remote control must

make sure that no one is checking or operating the unit. For this purpose, a second warning plate should be provided at the remote control unit.



**AUTOMATIC COMPRESSOR CONTROL.  
UNIT MAY START WITHOUT WARNING!**

Before carrying out maintenance and repGas work, switch off at the main switch and ensure the unit will not restart.

Observe and maintain an ambient temperature range of 40 - 115 °F (5 - 45 °C).

The area in which the compressor unit is installed should be well lit and easily accessible to facilitate servicing and routine maintenance.

**11.2.2.2 Ventilation**

During normal compression, heat is generated by the compressor and by the drive motorengine. For Gas-cooled compressor units, this heat needs to be vented away by sufficient ventilation.

**11.2.2.2.1 Outdoor Installation**

It is recommended that all gasoline and diesel engine driven compressor units be installed outdoors. Electrically driven compressor units may be installed outdoors only if enclosed with weatherproof enclosure panels.

**11.2.2.2.2 Indoor Installation**

The best location to install the compressor unit indoors is against an outside wall with a suitably large Gas vent in front of the cooling fan. Additionally, it is necessary to position an exhaust opening in the opposite wall, close to the ceiling or in the ceiling.

As a basic rule of thumb, the room should be ventilated sufficiently so as to prevent the ambient room temperature from exceeding 105 °F (41 °C). Additional heat generating equipment or piping should be avoided or must be well insulated.

**11.2.2.2.3 Natural Ventilation**

Natural ventilation should only be used up to a maximum drive power of 20 Hp. Units with higher powered drives should incorporate forced ventilation. To determine the size of the required intake and exhaust openings for natural ventilation, refer to the following table:

Drive Hp	Intake and Exhaust Openings Dependent on Room Volume (V) and Height (h)					
	V = 1750 ft <sup>3</sup> h = 6.5 ft		V = 3500 ft <sup>3</sup> h = 10 ft		V = 7000 ft <sup>3</sup> h = 13 ft	
	Intake (ft <sup>2</sup> )	Exhaust (ft <sup>2</sup> )	Intake (ft <sup>2</sup> )	Exhaust (ft <sup>2</sup> )	Intake (ft <sup>2</sup> )	Exhaust (ft <sup>2</sup> )
3	1.3	1.1	...	...	...	...
5	3.2	2.7	1.3	1.1	...	...
7.5	4.5	3.8	2.6	2.2	2.3	1.1
10	9.7	8.1	6.5	5.4	2.6	2.2
15	14.5	12.4	9.7	8.1	5.8	4.8
20	20.6	17.2	15.6	12.9	9.7	8.1



**11.2.2.2.4 Forced Ventilation**

Forced ventilation should be utilized on units with drive power higher than 20 Hp. For units with lower powered drive natural ventilation may be used. To determine the size of the required intake and exhaust openings for forced ventilation, refer to the following table

Drive Hp	Intake & Exhaust Openings Dependent on Room Volume (V) and Height (h) <sup>a</sup>					
	V = 1750 ft <sup>3</sup> h = 8 ft		V = 3500 ft <sup>3</sup> h = 10 ft		V = 7000 ft <sup>3</sup> h = 13 ft	
	Intake (ft <sup>2</sup> )	Exhaust cfm	Intake (ft <sup>2</sup> )	Exhaust cfm	Intake (ft <sup>2</sup> )	Exhaust cfm
25	3.3	3,300	3.2	3,200	3.0	3,000
30	4.0	3,960	3.8	3,840	3.6	3,600
40	5.3	5,280	5.1	5,120	4.8	4,800
50	6.6	6,600	6.4	6,400	6.0	6,000
60	7.9	7,920	7.7	7,680	7.2	7,200
75	9.9	9,900	9.6	9,600	9.0	9,000
100	13.2	13,200	12.8	12,800	12.0	12,000
125	16.5	16,500	16.0	16,000	15.0	15,000
150	19.8	19,800	19.2	19,200	18.0	18,000

a. The intake sizes given in the above table are for a cooling Gas velocity of 1000 ft.min. Bauer recommends that the cooling Gas velocity be in the range of 600 ft.min. to 2000 ft.min.

**11.2.3 Intake Gas**

The quality of Gas produced by the compressor unit is directly related to the quality of Gas that is taken in by the compressor. Bauer compressors require clean, dry, shop Gas for optimal performance. The intake Gas source must be free of contaminants such as fumes, engine exhaust, and solvents. If the intake source will be piped in adhere to the following general rules:

- Use PVC or similar material that will not corrode and contaminate the incoming Gas.
- The entire run should be the same sized piping
- Install a moisture trap with a drain prior to the compressor inlet
- If using glue on the piping, allow sufficient time for the vapors to dissipate before using the compressor

**11.2.3.1 Inside Gas Source**

The location of the compressor and its Gas intake are significant to the quality of the Gas produced and the performance of the drying system. Locating the Gas intake near other heat producing equipment must be avoided when possible. A close proximity to water heaters, boilers, and such are potential contaminants to the quality of the processed Gas. Drying cartridge lifespans are dramatically reduced when the processed Gas's temperature is elevated. Inadequate ventilation reduces the ability of the compressor to cool itself or the Gas being compressed.

High levels of CO<sub>2</sub> are another cause of breathing Gas to become contaminated. CO<sub>2</sub> limits are 1,000 ppm, and most fresh Gas already contains about 330 ppm. A number of people inside poorly ventilated rooms can easily bring the CO<sub>2</sub> levels up to 600 ppm or more. If high levels of CO<sub>2</sub> are normally present at the compressor intake, increased ventilation may alleviate the problem. Moving the intake to an outside location is another viable solution.

**11.2.3.2 Outside Gas Source**

Moving a compressor’s Gas intake to an outside location can improve the quality of the processed Gas and increase the lifespan of the drying filters. Before moving a compressor’s intake to an outside location take into account the changing conditions that may occur around where the Gas intake will be. Other exhausts vents, vehicle or machinery exhausts and fumes may contaminate the Gas in the area you wish to place your Gas intake. Gas samples can be taken and submitted for laboratory analysis if there are any doubts in the Gas quality.

If your Gas source is located outside, inspect the inlet piping regularly to ensure nothing has obstructed or contaminated the Gas that is being taken in.

**11.2.4 Compressor Intake Piping**

It is best to keep intake piping as short and straight as possible. Minimum height should be 8 - 10 ft. The end of the piping should point downward to avoid precipitation. Nothing should be allowed to restrict the Gas flow.

Breathing Gas can often fail to meet CGA standards, unless procedures are taken to provide a fresh Gas source for the compressor intake. The inlet source should be the cleanest ambient Gas available. Factors to consider when installing compressor intake piping in a building are the length of pipe, the diameter, and the number of 90° bends. All intake pipes must have a bug screen on the inlet end to prevent birds, bugs, or large debris from entering the inlet system. A goose-neck end or water trap on the pipe will prevent water from entering the compressor system. See the following table for recommended inlet pipe diameter.

<b>Guideline for Intake Piping with Max. Four 90° bends</b>		
<b>Inlet Capacity</b>	<b>Distance</b>	<b>Pipe Diameter<sup>a</sup></b>
<b>&lt; 13 SCFM</b>	<50 ft	2"
	50 - 100 ft	3"
	100 - 150 ft	4"
<b>13 - 30 SCFM</b>	<50 ft	3"
	50 - 100 ft	4"
	100 - 150 ft	5"
<b>30 - 50 SCFM</b>	≤50 ft	4"
	50 - 100 ft	5"
	100 - 150 ft	6"

a. Add 1" of pipe diameter if the number of 90° bends exceeds four

### 11.2.5 Installation Procedures

1. Use PVC pipe for ease of installation.
2. Ensure pipe is attached securely to the wall
3. Terminate the PVC pipe 3 to 5 ft from the compressor intake with a stub reducer the same size as the compressor inlet housing pipe.

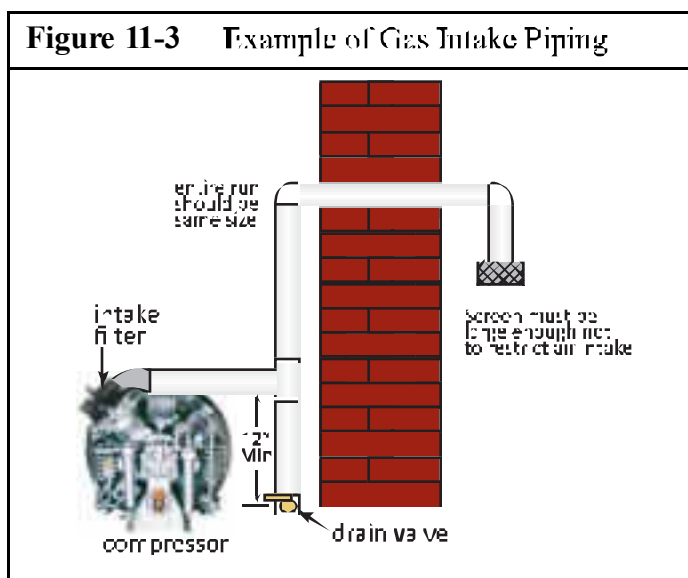

### 11.2.6 Electrical Installation

#### 11.2.6.1 Electric Drive

When making the electrical connections to the system, the following instructions are mandatory:

- Comply with all local, state and federal regulations concerning electrical installation.
- Arrange for the electrical connections to be made by a certified electrician only.
- Ensure that the motor voltage, control unit voltage, and frequency conform with the main voltage and frequency. Do not connect the compressor unit to a voltage other than the one specified on the nameplate.
- Provide all necessary cables and main fuses and a master disconnect switch. The fuse protection for the compressor must be carried out in compliance with local, state and national electrical regulations.

#### 11.2.6.2 Electrical Supply

The machine is factory wired according to order. If the voltage is to be changed, consult the factory for instructions and necessary parts.

For standard models the only customer wiring necessary is from the customer supplied disconnect switch to the compressor unit electrical enclosure. All wiring should be done by a licensed electrician familiar with national, state and local electrical codes.

The label shown in Figure 11-1 indicates where the incoming power is connected to the compressor unit electrical enclosure. This label must be removed before using the equipment.

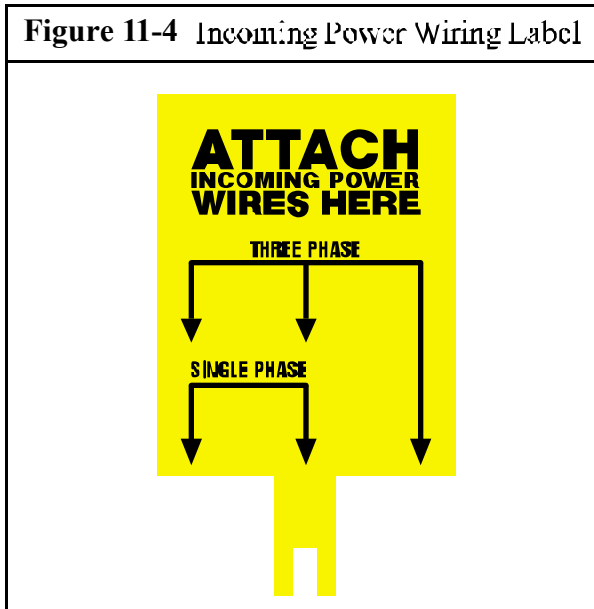

The use of improperly sized wire can result in sluggish operation, unnecessary tripping of overload relays and/or blowing of fuses. The following tables are provided as a guide for proper wire size

1 PHASE									
Motor Hp	Full Load Amps			Fuse Amps <sup>a</sup>			Minimum Wire Size <sup>b</sup>		
	120 V	208 V	230 V	120 V	208 V	230 V	120 V	208 V	230 V
2	24	13.2	12	30	20	17.5	10	...	14
3	34	18.7	17	50	30	25	8	10	10
5	56	30.8	28	80	50	40	4	8	8
7.5	80	44	40	100	70	60	3	8	8
10	...	55	50	...	90	60	...	6	6

- a. Dual element time delay fuse Amps.
- b. Normal Copper wire with THW, THWN, or XHHW insulation.

### 3 PHASE

Motor Hp	Full Load Amps			Fuse Amps <sup>a</sup>			Minimum Wire Size <sup>b</sup>		
	208 V	230 V	460V	208 V	230 V	460V	208 V	230 V	460V
2	7.5	6.8	3.4	12	10	5.6	14	14	14
3	10.6	9.6	4.8	17.5	15	8	14	14	14
5	16.7	15.2	7.6	25	25	12	10	12	14
7.5	24.2	22	11	40	30	17.5	8	10	14
10	30.8	28	14	50	40	20	8	8	12
15	46.2	42	21	60	60	30	6	6	10
20	59.4	54	27	90	80	40	4	4	8
25	74.8	68	34	100	100	50	3	4	8
30	88	80	40	125	100	60	2	3	8
40	114	104	52	175	150	80	1/0	1	6
50	143	130	65	200	200	100	3/0	2 0	4
60	169	154	77	250	200	100	4/0	3 0	3
75	211.2	192	96	300	300	150	300 mcm <sup>c</sup>	250 mcm	1
100	273	248	124	400	350	175	500 mcm	350 mcm	20
125	343.2	312	156	500	400	200	700 mcm	600 mcm	30
150	396	360	180	600	500	250	900 mcm	700 mcm	40
175	—	—	203	—	—	300	—	—	300 mcm

a. Dual element time delay fuse Amps.

b. Normal Copper wire with THW, THWN or XHHW insulation.

c. mcm = 1,000 circular mils

In the above tables, all values are based on 2011 NEC articles 430 and 310 (NFPA 70). These values are provided as a general guide; however, the information given on the motor nameplate supersedes the above information.

### 11.2.7 Pneumatic Leaks

Each unit is tested prior to leaving the manufacturing facility. All loose or leaking fittings are tightened prior to shipping. During the shipping process pneumatic connections may work loose and leaks may develop. Ensure each unit is leak tested prior to being placed in full operational usage.



## WARNING

Never tighten or adjust fittings or connections under pressure. Always de-pressurize first.

## 11.3 Long Term Storage

### 11.3.1 General

If the compressor unit will be out of service for more than six months, it should be preserved in accordance with the following instructions:

1. Make sure that the compressor is kept indoors in a dry, dust-free room.
2. Cover the compressor with plastic sheets only if no condensation will form under the sheet.
3. Remove the sheet from time to time and clean the outside of the unit.
4. If this procedure cannot be followed, or if the compressor will be out of service for more than 24 months, please contact Bauer Product Support for special instructions.

### 11.3.2 Preparations

Prior to preserving the compressor unit, it must be run until warm, i.e., up to the specified service pressure. Operate the unit for approximately 10 minutes, then carry out the following checks.

1. Check all pipes, filters and valves (including safety valves) for leakage.
2. Tighten all couplings, as required.
3. After 10 minutes, open the outlet valve and operate the compressor at adjusted minimum pressure using the pressure maintaining valve for approximately 5 minutes.
4. After the 5 minutes, shut the compressor unit down and completely drain all separators and filters. Close all valves.
5. Remove filter heads and lubricate the threads with petroleum jelly.

#### 11.3.2.1 Units Equipped with a Filter System

1. Ensure that cartridges remain in the drying system chambers. This will prevent oil from entering the outlet lines as a result of preservation procedures.
2. Remove the drying inlet tubing completely.

### 11.3.3 Preserving the Compressor

1. Operate the compressor again and slowly spray approximately 0.35 oz. (10 cc) of oil into the inlet port while the compressor is running. Keep the shut-off valve and the condensate drain valves open.
2. After spraying the oil into the inlet port, run the compressor unit for an additional 5 minutes before shutting the compressor unit down.

3. Close the shut-off valve and condensate drain valves.
4. Close the inlet port with a dust cap and/or tape.

### **11.3.4 Preventive Maintenance During Storage**

Operate the compressor once every six months as follows:

1. Remove the dust cap from the inlet port and install the inlet filter.
2. Open the outlet valve and allow the system to run approximately 5 minutes until there is outflow from the valve and oil is visible in the sight glass of the oil regulating valve.
3. Shut down the compressor.
4. Open the condensate drain valves, de-pressurize the unit, then close the drain valves again.
5. Remove the intake filter and replace the dust cap on the inlet port.

### **11.3.5 Lubrication Oils for Preservation**

1. After prolonged storage periods, the oil will age in the compressor crankcase. The oil must be drained at least every 24 months and replaced with fresh oil.
2. The stated period can only be attained when the crankcase is sealed during the preservation period in accordance with the preservation requirements.
3. After changing the oil, the compressor must be operated according to the instructions above.
4. Check the lubrication of the compressor during the every-six-month brief operation.
5. The oil pump is functioning properly when oil can be seen flowing through the sight glass of the oil pressure regulator or if the oil pressure gauge indicates the prescribed pressure.

### **11.3.6 Reactivating the Compressor Unit**

1. Remove any dust cap or tape from the inlet port and install an intake filter cartridge.
2. Change the oil, ensuring proper oil level when refilled.
3. The rotor must be thoroughly dry before applying power.
4. For units with a drying system, change all cartridges.
5. Run the compressor with open outlet valve for approximately 10 minutes. Check for proper operation of the lubricating system.
6. After 10 minutes, close the shut-off valve and run the system up to final pressure until the final pressure safety valve vents. On compressor units with a compressor control system, raise the pressure switch setting the switch above normal limits to override the pressure switch. Be sure to reset the switch after checking.
7. Check the interstage safety valves for leakage.
8. Establish the cause of any faults and remedy.
9. Stop the unit when it is running properly. The compressor is then ready for operation.

### 11.4 Reproducible Forms

#### 11.4.1 Scheduled Maintenance Form

Daily	Para.	Date	Signature



<b>Weekly or as required.</b>	<b>Para.</b>	<b>Date</b>	<b>Signature</b>

<b>500 Operating Hours.</b>	<b>Para.</b>	<b>Date</b>	<b>Signature</b>

<b>1,000 Operating Hours.</b>	<b>Para.</b>	<b>Date</b>	<b>Signature</b>

<b>2,000 Operating Hours.</b>	<b>Para.</b>	<b>Date</b>	<b>Signature</b>

3,000 Operating Hours.	Para.	Date	Signature

Annually.	Para.	Date	Signature

Biennially. (Every two years)	Para.	Date	Signature

**11.4.2 Cartridge Operating Hours**

Date	Operating hours	Ambient temp. + 18°F during compression	Correction factor	Adjusted cartridge hours	
				Today	Total

MNL-0021

**11.4.3 Record of Operating Hours**

<b>Date</b>	<b>Minutes</b>	<b>Total</b>
Subtotal:		

<b>Date</b>	<b>Minutes</b>	<b>Total</b>
Subtotal:		

**11.5 Reference Data**

**11.5.1 Tightening Torque Values**

1. Unless otherwise specified in text, the torque values in Table 1 apply.
2. The indicated torque values are valid for bolts in greased condition.
3. Self locking nuts must be replaced on reassembly
4. Pipe connections (swivel nuts) should be tightened just enough so that leakage is stopped. Not more than finger tight plus up to an additional half turn.

<b>Table 11-1: Torque Values</b>		
<b>Bolt or Screw</b>	<b>Size</b>	<b>Max. Torque</b>
Hex and Socket Head	1/4 in (6 mm)	7 ft-lb. (9.5 N m)
Hex and Socket Head	5/16 in (8 mm)	18 ft-lb. (24.4 N m)
Hex and Socket Head	3/8 in (10 mm)	32 ft-lb. (43.4 N m)
Hex and Socket Head	1/2 in. (12 mm)	53 ft-lb. (71.9 N m)
Hex and Socket Head	9/16 in (14 mm)	85 ft-lb. (115.3 N m)
Hex and Socket Head	5/8 in (16 mm)	141 ft-lb. (191.2 N m)

**11.5.2 Torque Sequence Diagrams**

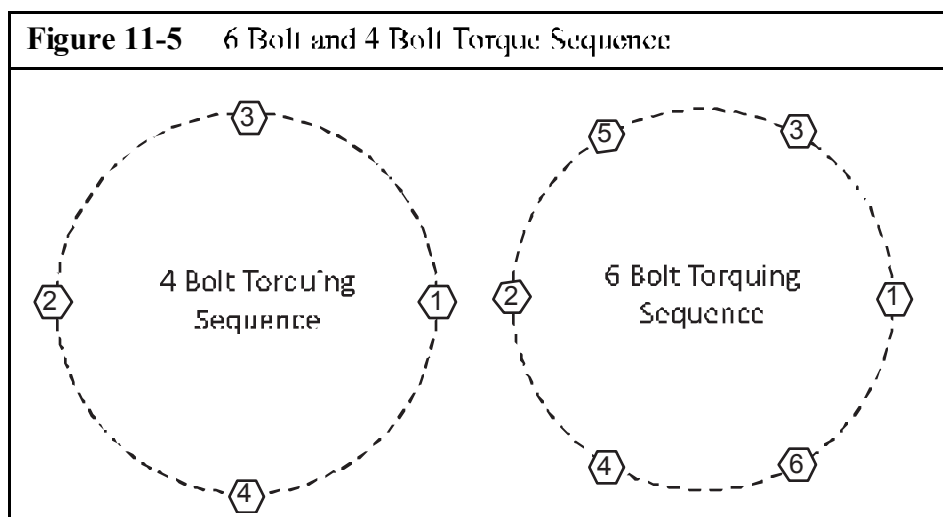

**11.5.3 Conversion Formulas**

$^{\circ}\text{F} = 9/5 \text{ }^{\circ}\text{C} + 32$   
 $\text{psi} = \text{bar} \times 14.5$

$^{\circ}\text{C} = 5/9 \times (^{\circ}\text{F} - 32)$   
 $\text{bar} = \text{psi} \times 0.0689$

### 11.5.4 Approved Lubricants Chart

Unless otherwise specified in text, use the lubricants in Table 2.

Table 11-2: Lubricant Chart	
Usage	Lubricants
O-rings, rubber and plastic parts; filter housing threads, sealing rings	Parker Super "O" Tube
Bolts, nuts, studs, valve parts, Copper gaskets and tube connection parts (threads, cap nut and compression rings)	Never-Seez® NSWT, Pipe Dope or teflon tape
Paper gaskets	DOW Corning 732 or equivalent silicone compound applied on both sides before assembly,
High temperature connections	DOW Corning 732 or equivalent temperature resistant compound,
Tube connection ferrules,	Never-Seez® NSWT

### 11.5.5 Glossary of Abbreviations and Acronyms

AC	Activated Charcoal, removes odor and taste
ACD	Automatic Condensate Drain
ASME	American Society of Mechanical Engineers
CW	Clock Wise
CCW	Counter-Clockwise
CGA	Compressed Gas Association
DIN	Deutsches Institut für Normung (≈ ASME)
DOT	Department of Transportation
E1	single phase electrical supply (Electric 1)
E3	three phase electrical supply (Electric 3)
HP	Hopcalite, a chemical catalyst which converts carbon monoxide to carbon dioxide
IAW	In Accordance With
MS	Molecular Sieve, removes moisture
NEC	National Electrical Code
NEMA	National Electrical Manufacturers Association
NFPA	National Fire Protection Association
OSHA	Occupational Safety & Health Administration
ODP	Open Drip-proof (motor)
OEM	Original Equipment Manufacturer
PLC	Programmable Logic Controller
PMV	Pressure Maintaining Valve
SC	Securus® moisture sensing device

## **11.6 Additional Documents**

### **11.6.1 Diagrams and Drawings**

Any included drawings, wiring diagrams, pneumatic flow diagrams, etc., will be bound next to the back cover in a hard copy manual or included as a separate file on a CD.

### **11.6.2 Other Documents**

OEM Manuals and other Bauer manuals may be included in the documentation shipping package.

## CORRECTIONS & COMMENTS

In an effort towards constant improvement, the Documentation section of Bauer Compressors, Inc. would like to give you the opportunity to suggest improvements or corrections to this manual. If you find any inaccuracies or have suggestions feel free to E-mail us at: *documentation@bauercomp.com*, or fill out the form below and mail it to us:

### Submitters Contact Information:

Name: \_\_\_\_\_

Address: \_\_\_\_\_  
(number & street)

\_\_\_\_\_ (city, state & zip)

E-mail: \_\_\_\_\_  
(optional)

### Unit Information:

Model: \_\_\_\_\_

Serial#: \_\_\_\_\_

Block#: \_\_\_\_\_

MFG Date: \_\_\_\_\_

Inaccuracies: page# \_\_\_\_\_ figure# \_\_\_\_\_ paragraph# \_\_\_\_\_

---

---

---

---

---

---

Suggested Corrections: \_\_\_\_\_

---

---

---

---

---

---

Additional Comments: \_\_\_\_\_

---

---

---

---

---

---



fold here



place  
postage  
here

**Bauer Compressors, Inc.**  
**Attn: Documentation**  
**1328 Azalca Garden Rd.**  
**Norfolk, VA 23502-1944**

fold here



tape or glue here