



FCC Test Report
**FCC Part 15.247 for FHSS systems/
CANADA RSS-210**

FOR:

Broadcom Corporation
Bluetooth Transceiver Module
Model Number: UGPZ9
FCC ID: QDS-BRCM1026
IC-ID: 4324A-BRCM1026

TEST REPORT #: BROAD_031_01001_15.247BT
DATE: 5/16/2007



FCC listed#
101450
IC recognized #
3925

CETECOM Inc.

411 Dixon Landing Road • Milpitas, CA 95035 • U.S.A.

Phone: + 1 (408) 586 6200 • Fax: + 1 (408) 586 6299 • E-mail: info@cetecomusa.com • <http://www.cetecom.com>

CETECOM Inc. is a Delaware Corporation with Corporation number: 2113686
Board of Directors: Dr. Harald Ansoerge, Dr. Klaus Matkey, Hans Peter May



TABLE OF CONTENTS

1 Assessment _____ **4**

Technical responsibility for area of testing: _____ **4**

 EMC & Radio _____ **4**

This report is prepared by: _____ **4**

 EMC & Radio _____ **4**

2 Administrative Data _____ **5**

2.1 Identification of the Testing Laboratory Issuing the EMC Test Report _____ **5**

2.2 Identification of the Client _____ **5**

2.3 Identification of the Manufacturer _____ **5**

3 Equipment under Test (EUT) _____ **6**

3.1 Specification of the Equipment under Test _____ **6**

Subject Of Investigation _____ **7**

3.2 RESTRICTED BAND EDGE COMPLIANCE RADIATED §15.247/15.205 _____ **8**

 3.2.1 LIMITS _____ **8**

 3.2.2 RESULTS: GFSK (Antenna: WHA YU/C680-520022-A) _____ **9**

 3.2.3 RESULTS: GFSK (Antenna: WHA YU/C680-520022-A) _____ **13**

 3.2.4 RESULTS: GFSK (Antenna: HITACH/ HFS27-SO01) _____ **17**

 3.2.5 RESULTS: GFSK (Antenna: HITACH/ HFS27-SO01) _____ **21**

3.3 TRANSMITTER SPURIOUS EMISSIONS RADIATED § 15.247/15.205/15.209 _____ **25**

 3.3.1 LIMITS _____ **25**

 3.3.2 RESULTS _____ **26**

3.4 RECEIVER SPURIOUS RADIATION § 15.209/RSS210 _____ **34**

 3.4.1 LIMITS _____ **34**

 3.4.2 RESULTS _____ **35**

4 Measurements (CONDUCTED) _____ **39**

4.1 MAXIMUM PEAK OUTPUT POWER § 15.247 (CONDUCTED) _____ **39**

 4.1.1 LIMIT SUB CLAUSE § 15.247 (b) (1) _____ **39**

4.2 20dB BANDWIDTH _____ **46**

 4.2.1 LIMIT SUB CLAUSE § 15.247 (a) (1) (i) (ii) (iii) _____ **46**

4.3 CARRIER FREQUENCY SEPARATION _____ **53**

 4.3.1 LIMIT SUB CLAUSE § 15.247 (a) (1) (i) (ii) (iii) _____ **53**

 4.3.2 RESULTS: _____ **53**

4.4 CARRIER FREQUENCY SEPERATION §15.247(a) _____ **54**

4.5 NUMBER OF HOPPING CHANNELS _____ **55**

 4.5.1 LIMIT SUB CLAUSE § 15.247 (a) (1) (iii) _____ **55**

 4.5.2 RESULTS: _____ **55**

4.6 TIME OF OCCUPANCY (DWELL TIME) _____ **57**

 4.6.1 LIMIT SUB CLAUSE § 15.247 (a) (1) (i) (ii) (iii) _____ **57**

4.7 CONDUCTED SPURIOUS EMISSION _____ **59**

Test Report #: **BROAD_031_01001_15.247BT**

Date of Report : 2007-05-16

Page 3 of 65



5 TEST EQUIPMENT AND ANCILLARIES USED FOR TESTS _____ **63**

6 BLOCK DIAGRAMS _____ **64**



1 Assessment

The following is in compliance with the applicable criteria specified in FCC rules Part 15.247 of the Code of Federal Regulations and in compliance with the applicable criteria specified in Industry Canada rules RSS210.

Company	Description	Model #
Broadcom Corporation	Bluetooth Transceiver Module	UGPZ9

Technical responsibility for area of testing:

Peter Mu
2007-05-16 EMC & Radio (EMC Project Engineer)

Date	Section	Name	Signature
------	---------	------	-----------

This report is prepared by:

Pete Krebill
2007-05-16 EMC & Radio (EMC Project Engineer)

Date	Section	Name	Signature
------	---------	------	-----------

The test results of this test report relate exclusively to the test item specified in Identification of the Equipment under Test. The CETECOM Inc. USA does not assume responsibility for any conclusions and generalizations drawn from the test results with regard to other specimens or samples of the type of the equipment represented by the test item. The test report may only be reproduced or published in full. Reproduction or publication of extracts from the report requires the prior written approval of the CETECOM Inc USA.

2 Administrative Data



2.1 Identification of the Testing Laboratory Issuing the EMC Test Report

Company Name:	CETECOM Inc.
Department:	EMC
Address:	411 Dixon Landing Road Milpitas, CA 95035 U.S.A.
Telephone:	+1 (408) 586 6200
Fax:	+1 (408) 586 6299
Responsible Test Lab Manager:	Lothar Schmidt
Responsible Project Leader:	Pete Krebill

2.2 Identification of the Client

Applicant (Broadcom Corporation)	
Street Address	190 Mathilda Place
City/Zip Code	Sunnyvale, CA 94086
Country	USA
Contact Person	Daniel Lawless
Telephone	408-922-5870
e-mail	Michio.Kobayashi@jp.sony.com
Applicant (Company Name)	Broadcom Corporation

2.3 Identification of the Manufacturer

MANUFACTURER	
Manufacturer	Alps Electric Co., Ltd
Street Address	1-2-1, Okinouchi
City/Zip Code	Soma-city, Fukushima-pref., 976-8501
Country	Japan



3 Equipment under Test (EUT)

3.1 Specification of the Equipment under Test

EUT	
Description	Bluetooth Transceiver Module
Model No.	UGPZ9
FCC-ID	QDS-BRCM1026
IC-ID (Industry Canada)	BCM-BRCM1026

Frequency Range:	2402-2480MHz
Type(s) of Modulation:	GFSK <input type="checkbox"/> π/4DQPSK <input type="checkbox"/> DPSK/FHSS
Number of Channels:	79
Antenna Type:	See table below
Output Power :	2.73 mW

DESCRIPTION OF EACH Antenna (all antennas)			
Antenna Manufacturer / Model Number	Antenna Type (Dipole, Patch, Panel, Yagi, etc.)	Maximum Peak Antenna Gain (dBi)	Operating Mode
WHA YU/C680-520022-A	PIFA	+2.95dBi	<input checked="" type="checkbox"/> Point to Point <input type="checkbox"/> Point to Multipoint
WHA YU/C680-520070-A	PIFA	+0.61dBi	<input checked="" type="checkbox"/> Point to Point <input type="checkbox"/> Point to Multipoint
WHA YU/C680-520082-A	PIFA	+2.7dBi	<input checked="" type="checkbox"/> Point to Point <input type="checkbox"/> Point to Multipoint
HON HAI/WDAN-SCMS2003-1F	PIFA	-0.58dBi	<input checked="" type="checkbox"/> Point to Point <input type="checkbox"/> Point to Multipoint
HON HAI/WDAN-SCMC9004-1F	PIFA	+1.59dBi	<input checked="" type="checkbox"/> Point to Point <input type="checkbox"/> Point to Multipoint
HITACH/ HFS27-SO01	λ/4 mono-pole	+1.47dBi	<input checked="" type="checkbox"/> Point to Point <input type="checkbox"/> Point to Multipoint
Tyco/ 1981566-1	Inverted-F	+1.3dBi	<input checked="" type="checkbox"/> Point to Point <input type="checkbox"/> Point to Multipoint



Subject Of Investigation

All testing was performed on the product referred to in Section 3 as EUT. This test report contains full radiated testing as per FCC15.247 on the EUT with the Bluetooth module.

During the testing process the EUT was tested on a single channel using PRBS9 payload using DH5 packets, all data in this report shows the worst case between horizontal and vertical polarization for above 1GHz.

The objective of the measurements done by Cetecom Inc. was to measure the performance of the EUT as specified by requirements listed in FCC rules Part 15.247 of Title 47 of the Code of Federal Regulations and Industry Canada rules RSS210. The maximization of portable equipment is conducted in accordance with ANSI C63.4.



3.2 RESTRICTED BAND EDGE COMPLIANCE RADIATED §15.247/15.205

3.2.1 LIMITS

(a) Except as shown in paragraph (d) of this section, only spurious emissions are permitted in any of the frequency bands listed below:

MHz	MHz	MHz	GHz
0.090 - 0.110	16.42 - 16.423	399.9 - 410	4.5 - 5.15
¹ 0.495 - 0.505	16.69475 - 16.69525	608 - 614	5.35 - 5.46
2.1735 - 2.1905	16.80425 - 16.80475	960 - 1240	7.25 - 7.75
4.125 - 4.128	25.5 - 25.67	1300 - 1427	8.025 - 8.5
4.17725 - 4.17775	37.5 - 38.25	1435 - 1626.5	9.0 - 9.2
4.20725 - 4.20775	73 - 74.6	1645.5 - 1646.5	9.3 - 9.5
6.215 - 6.218	74.8 - 75.2	1660 - 1710	10.6 - 12.7
6.26775 - 6.26825	108 - 121.94	1718.8 - 1722.2	13.25 - 13.4
6.31175 - 6.31225	123 - 138	2200 - 2300	14.47 - 14.5
8.291 - 8.294	149.9 - 150.05	2310 - 2390	15.35 - 16.2
8.362 - 8.366	156.52475 - 156.52525	2483.5 - 2500	17.7 - 21.4
8.37625 - 8.38675	156.7 - 156.9	2690 - 2900	22.01 - 23.12
8.41425 - 8.41475	162.0125 - 167.17	3260 - 3267	23.6 - 24.0
12.29 - 12.293	167.72 - 173.2	3332 - 3339	31.2 - 31.8
12.51975 - 12.52025	240 - 285	3345.8 - 3358	36.43 - 36.5
12.57675 - 12.57725	322 - 335.4	3600 - 4400	(²)
13.36 - 13.41			

***PEAK LIMIT= 74dBuV/m**

***AVG. LIMIT= 54dBuV/m**



**3.2.2 RESULTS: GFSK (Antenna: WHA YU/C680-520022-A)
(2402MHz) LOWER BAND EDGE PEAK -GFSK MODULATION**

CETECOM Inc.

411 Dixon Landing Road, Milpitas CA 95035, USA

EUT: USB Bluetooth Module

Customer: Broadcom

Test Mode: BT CH 0, Modulation: GFSK

ANT Orientation: V

EUT Orientation: V (eut antenna)

Test Engineer: Ed

Power Supply:: via USB

Comments: Stump metal antenna

SWEEP TABLE: "FCC15.247 LBE_PK"

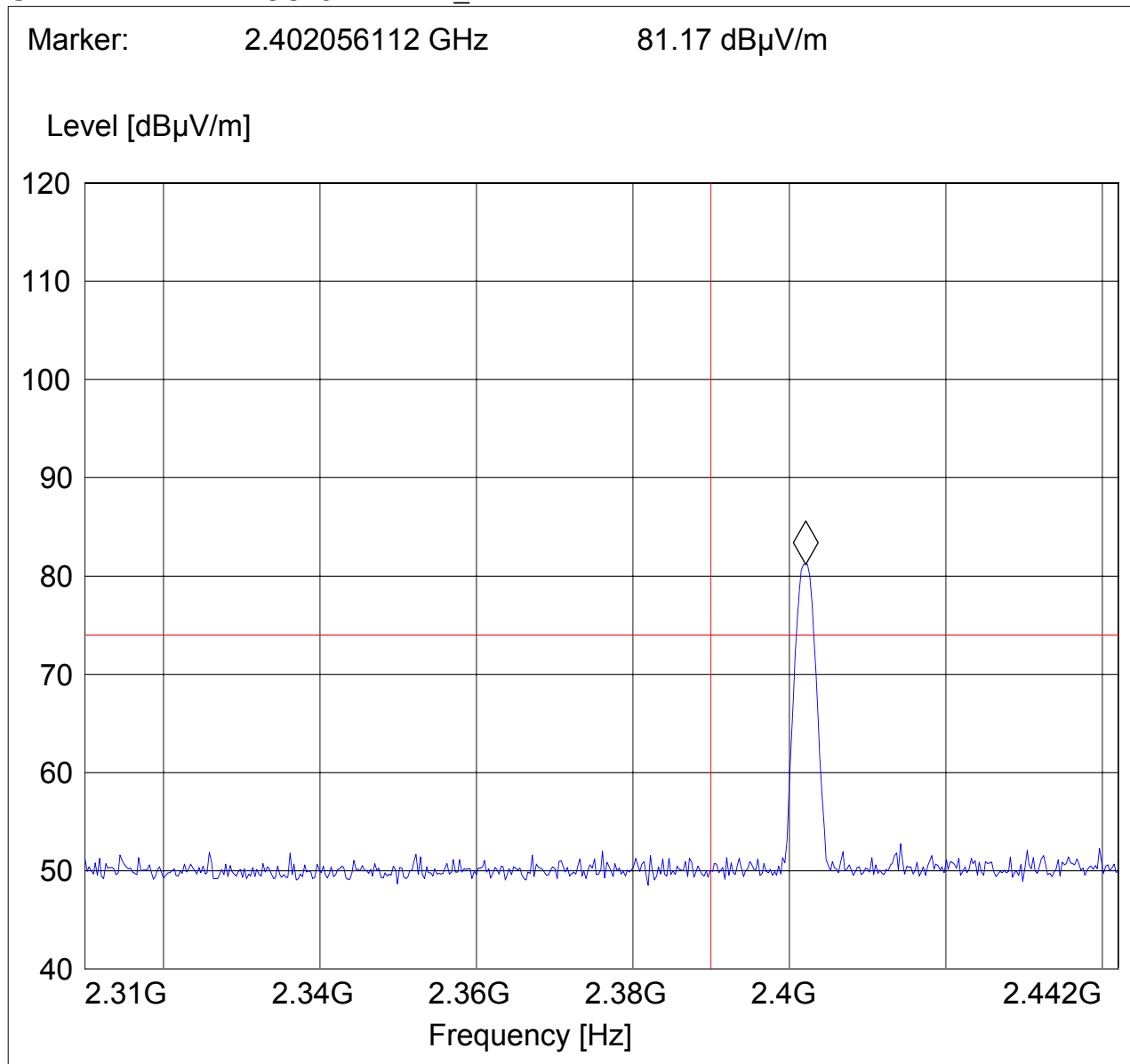



(2402MHz) LOWER BAND EDGE AVERAGE -GFSK MODULATION

CETECOM Inc.

411 Dixon Landing Road, Milpitas CA 95035, USA

EUT: USB Bluetooth Module

Customer: Broadcom

Test Mode: BT CH 0, Modulation: GFSK

ANT Orientation: V

EUT Orientation: V (eut antenna)

Test Engineer: Ed

Power Supply:: via USB

Comments: Stump metal antenna

SWEEP TABLE: "FCC15.247 LBE_AVG"

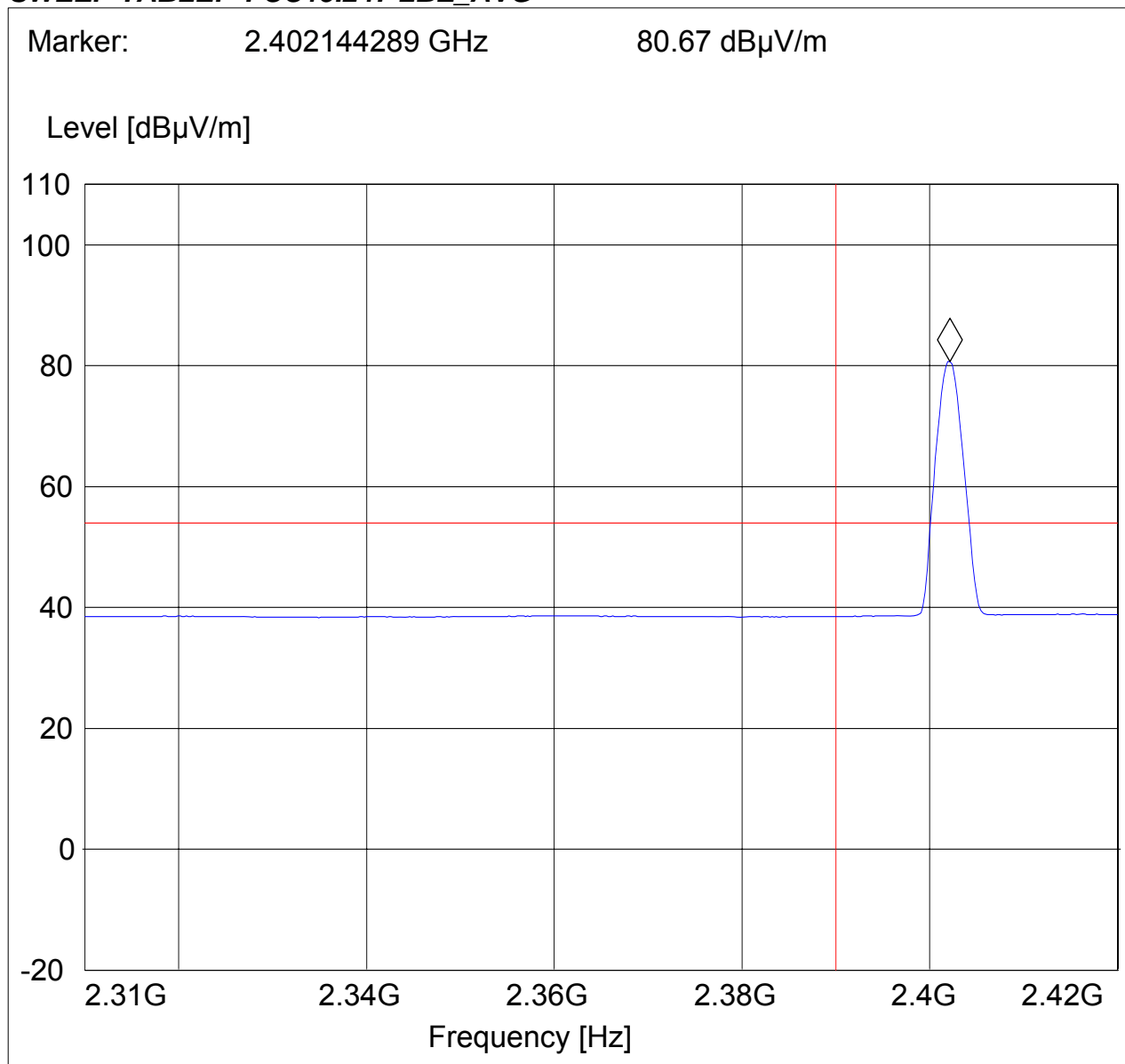



(2480MHz) HIGHER BAND EDGE PEAK -GFSK MODULATION

CETECOM Inc.

411 Dixon Landing Road, Milpitas CA 95035, USA

EUT: USB Bluetooth Module

Customer: Broadcom

Test Mode: BT CH 78, Modulation: GFSK

ANT Orientation: V

EUT Orientation: V (eut antenna)

Test Engineer: Ed

Power Supply:: via USB

Comments: Stump metal antenna

SWEEP TABLE: "FCC15.247 HBE_PK"

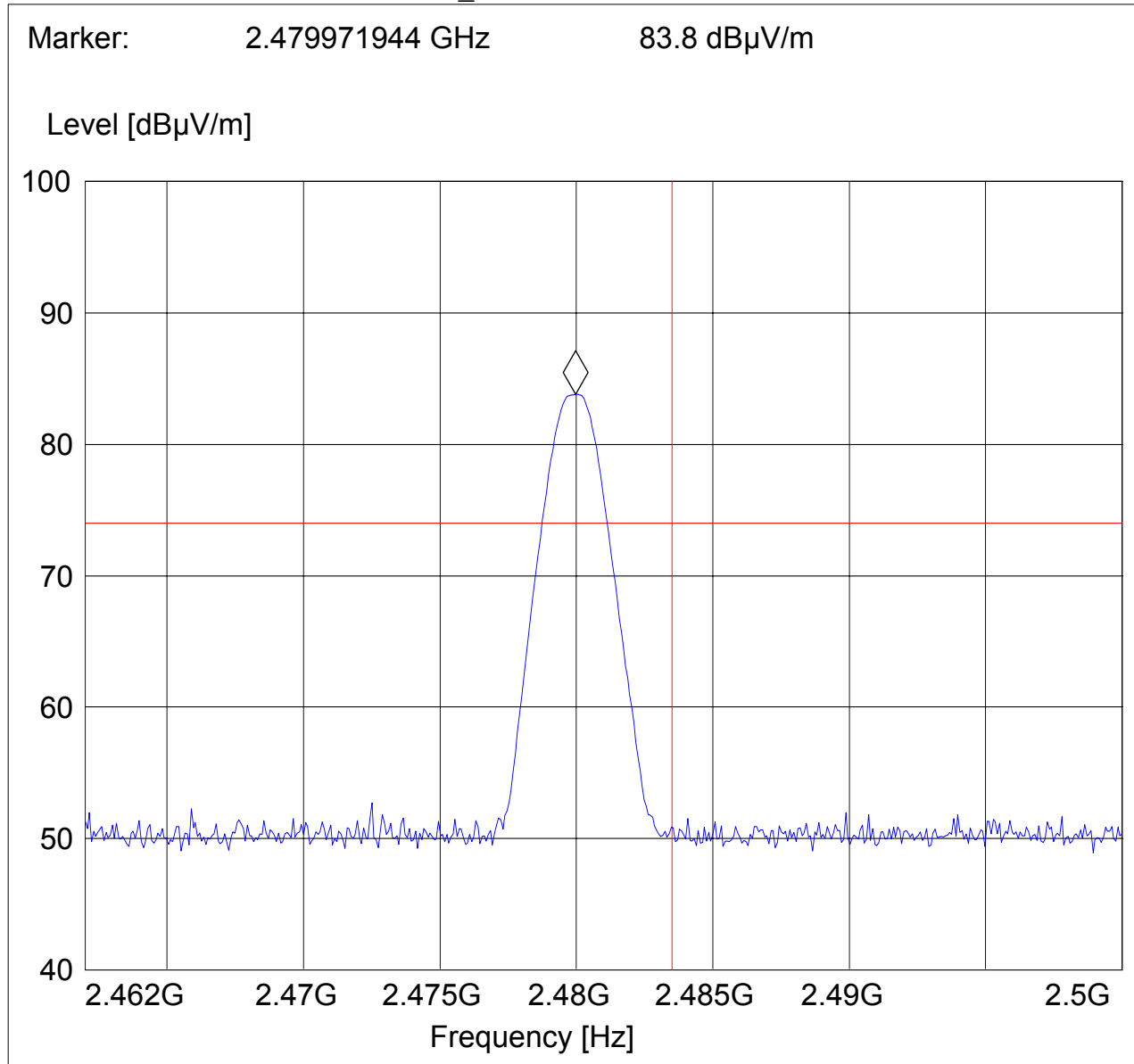



HIGHER BAND EDGE AVERAGE-GFSK MODULATION

CETECOM Inc.

411 Dixon Landing Road, Milpitas CA 95035, USA

EUT: USB Bluetooth Module

Customer: Broadcom

Test Mode: BT CH 78, Modulation: GFSK

ANT Orientation: V

EUT Orientation: V (eut antenna)

Test Engineer: Ed

Power Supply: via USB

Comments: Stump metal antenna

SWEEP TABLE: "FCC15.247 HBE_AVG"

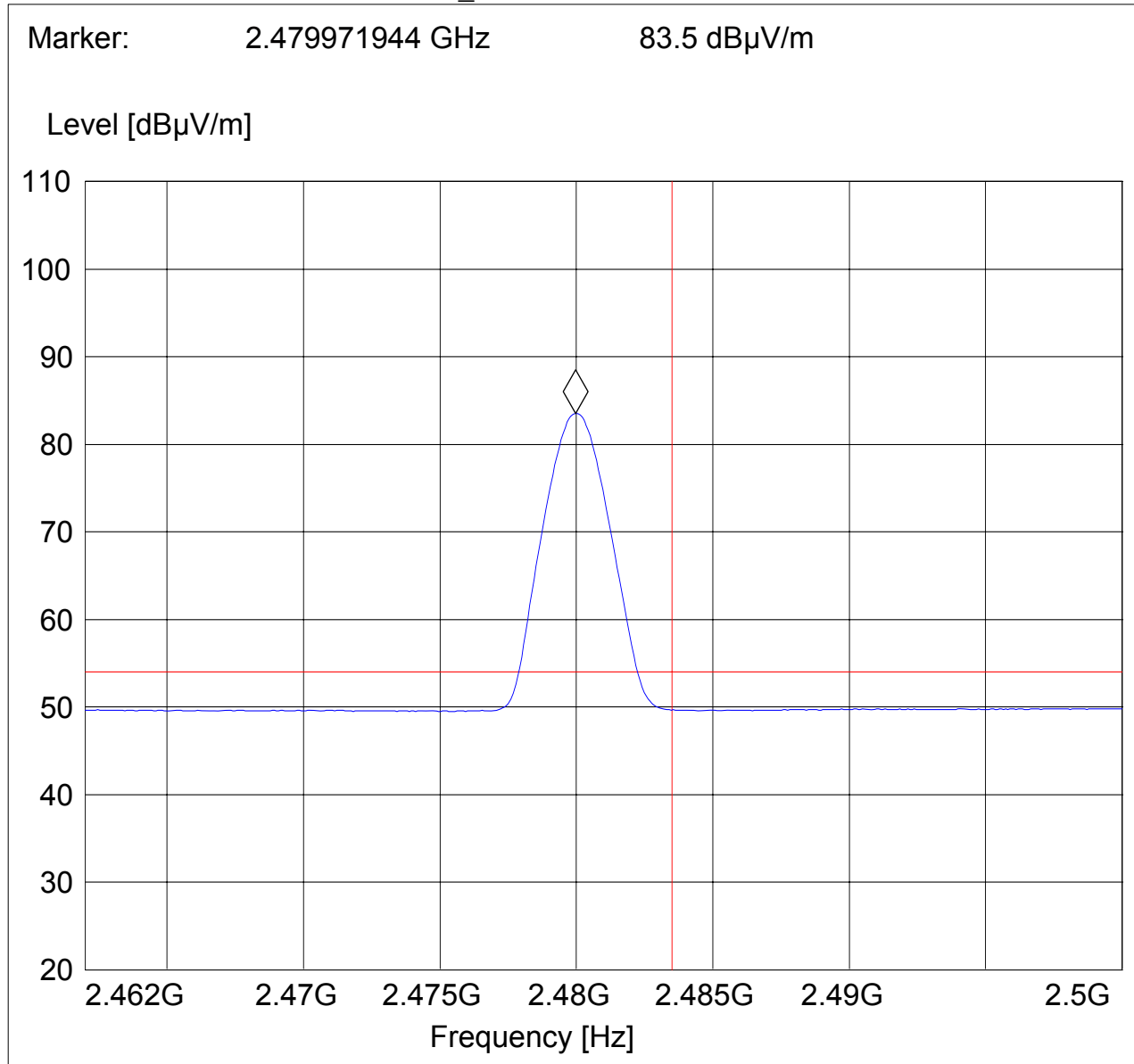



**3.2.3 RESULTS: GFSK (Antenna: WHA YU/C680-520022-A)
(2402MHz) LOWER BAND EDGE PEAK –8DPSK MODULATION**

CETECOM Inc.

411 Dixon Landing Road, Milpitas CA 95035, USA

EUT: USB Bluetooth Module

Customer: Broadcom

Test Mode: BT CH 0, Modulation: 8DPSK

ANT Orientation: V

EUT Orientation: V (eut antenna)

Test Engineer: Ed

Power Supply:: via USB

Comments: Stump metal antenna

SWEEP TABLE: "FCC15.247 LBE_PK"

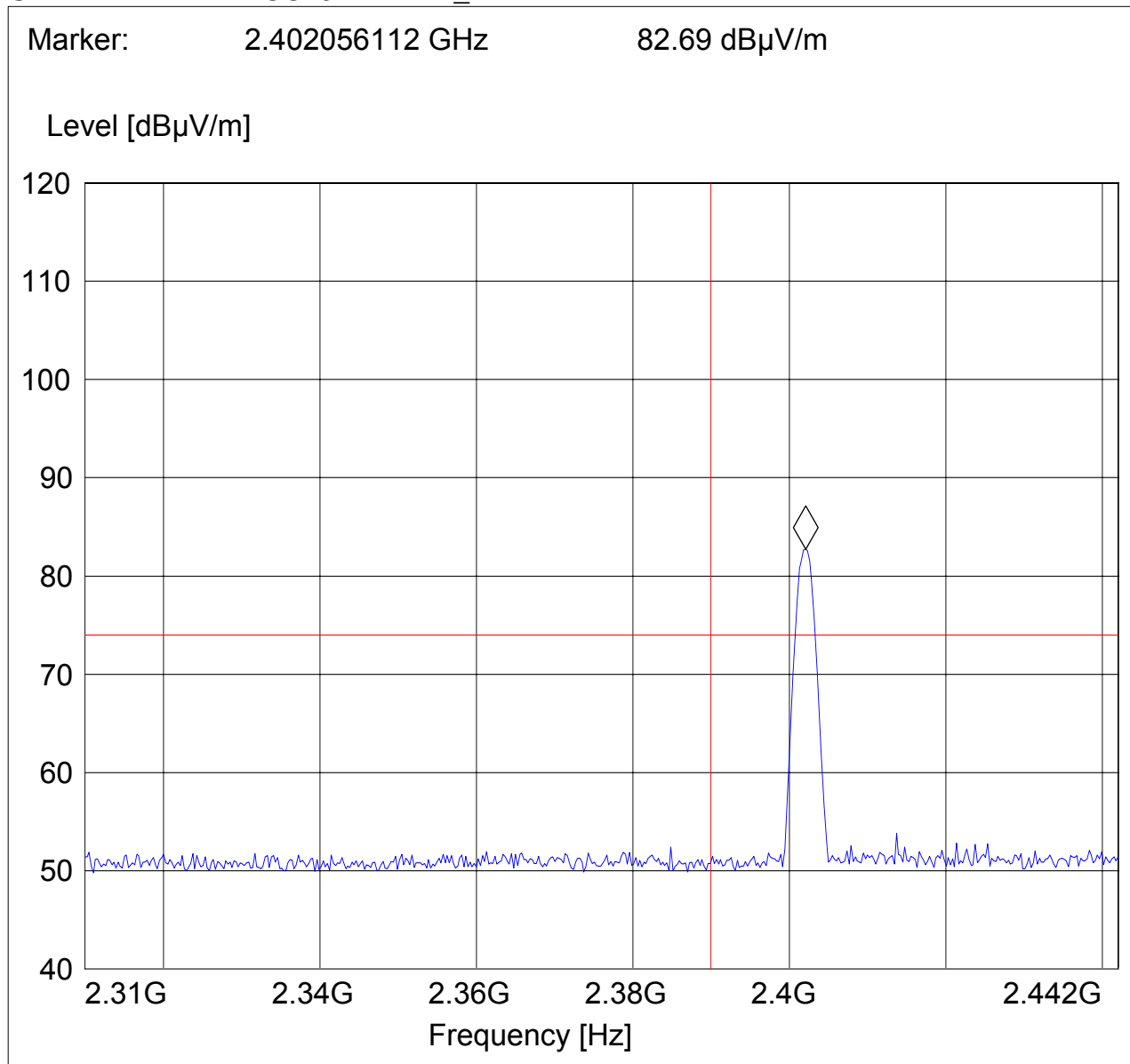



(2402MHz) LOWER BAND EDGE AVERAGE –8DPSK MODULATION

CETECOM Inc.

411 Dixon Landing Road, Milpitas CA 95035, USA

EUT: USB Bluetooth Module

Customer: Broadcom

Test Mode: BT CH 0, Modulation: 8DPSK

ANT Orientation: V

EUT Orientation: V (eut antenna)

Test Engineer: Ed

Power Supply:: via USB

Comments: Stump metal antenna

SWEEP TABLE: "FCC15.247 LBE_AVG"

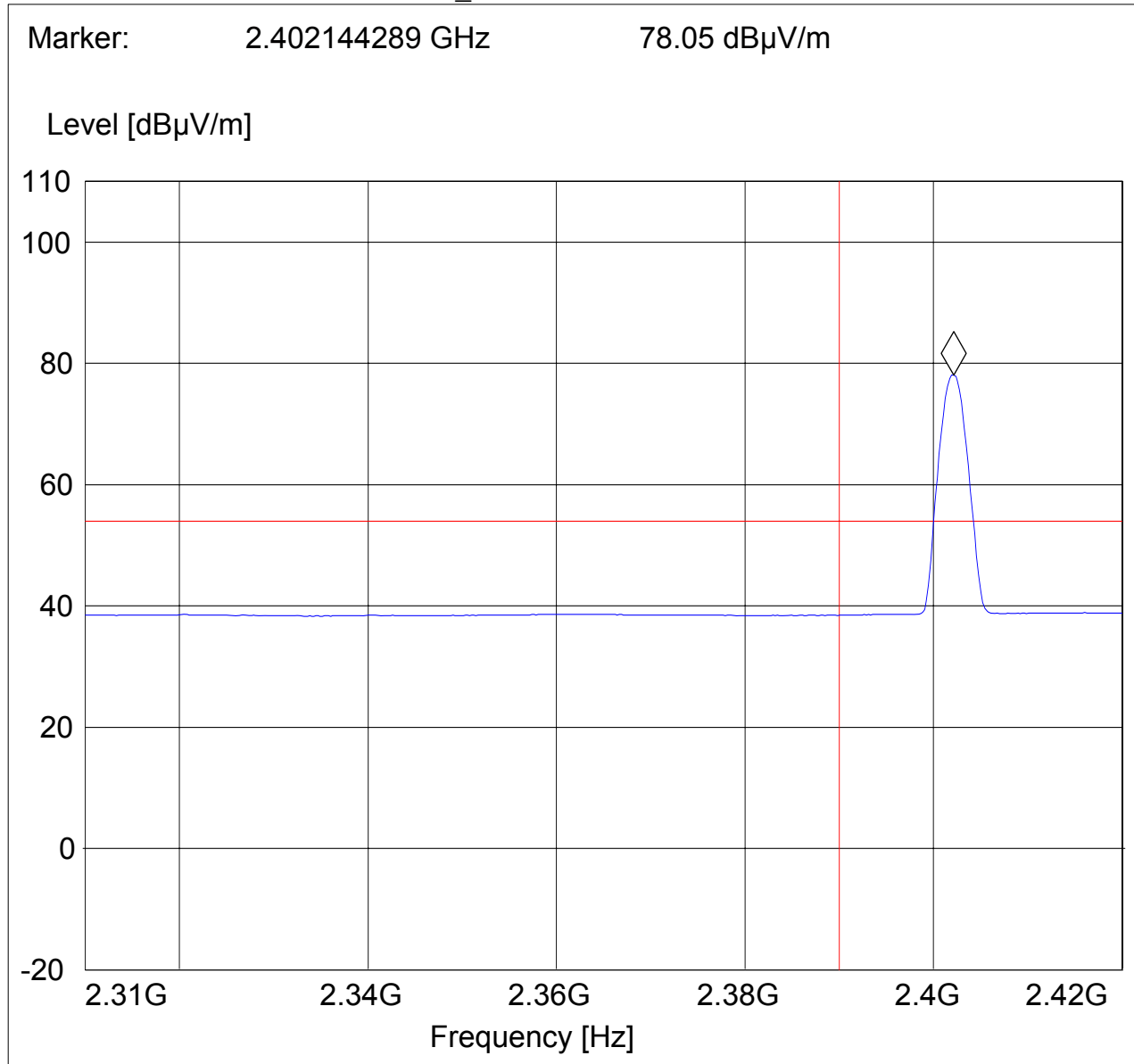



(2480MHz) HIGHER BAND EDGE PEAK –8DPSK MODULATION

CETECOM Inc.

411 Dixon Landing Road, Milpitas CA 95035, USA

EUT: USB Bluetooth Module

Customer: Broadcom

Test Mode: BT CH 78, Modulation: 8DPSK

ANT Orientation: V

EUT Orientation: V (eut antenna)

Test Engineer: Ed

Power Supply: via USB

Comments: Stump metal antenna

SWEEP TABLE: "FCC15.247 HBE_PK"

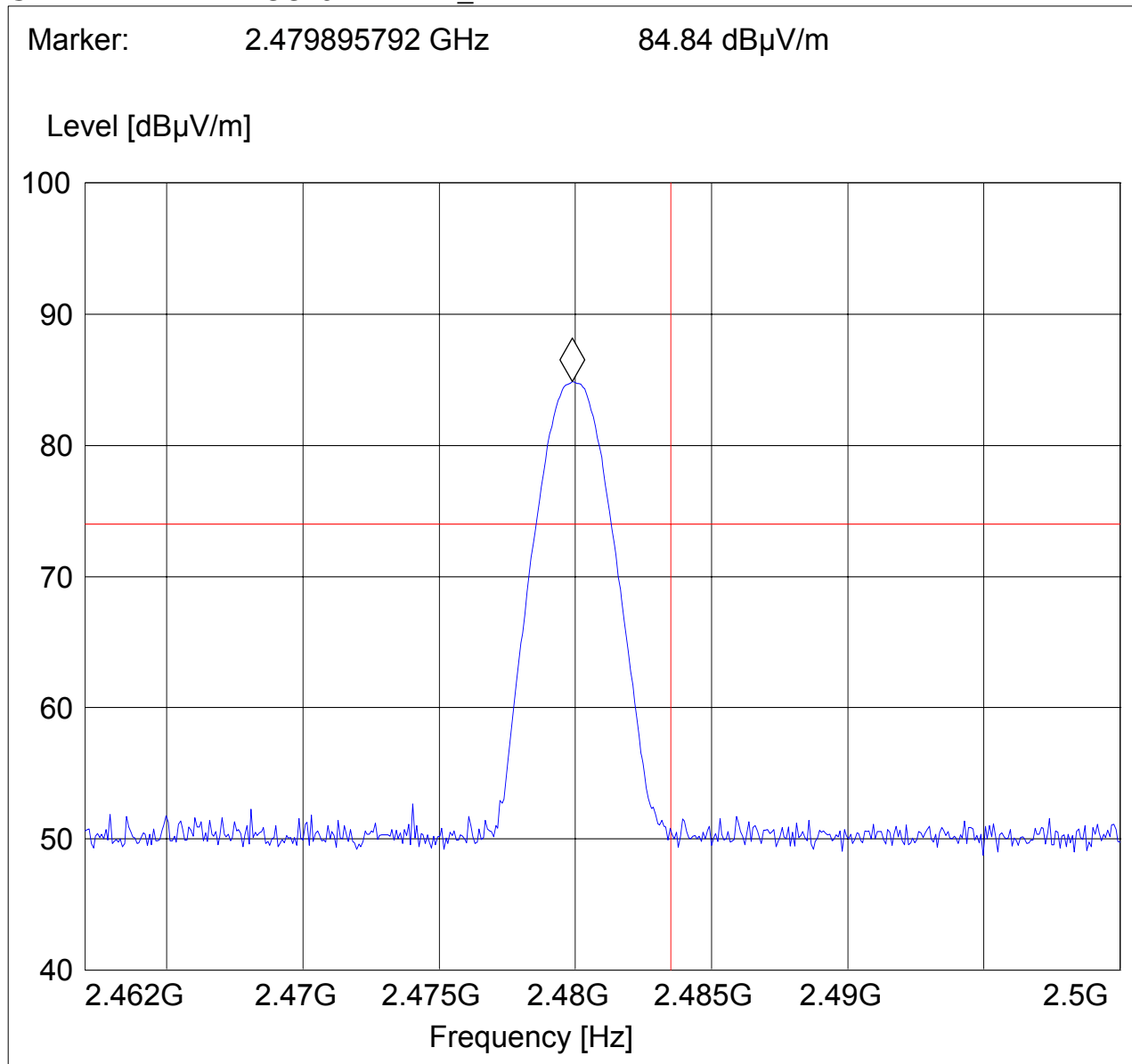



HIGHER BAND EDGE AVERAGE-8DPSK MODULATION

CETECOM Inc.

411 Dixon Landing Road, Milpitas CA 95035, USA

EUT: USB Bluetooth Module

Customer: Broadcom

Test Mode: BT CH 78, Modulation: 8DPSK

ANT Orientation: V

EUT Orientation: V (eut antenna)

Test Engineer: Ed

Power Supply: via USB

Comments: Stump metal antenna

SWEEP TABLE: "FCC15.247 HBE_AVG"

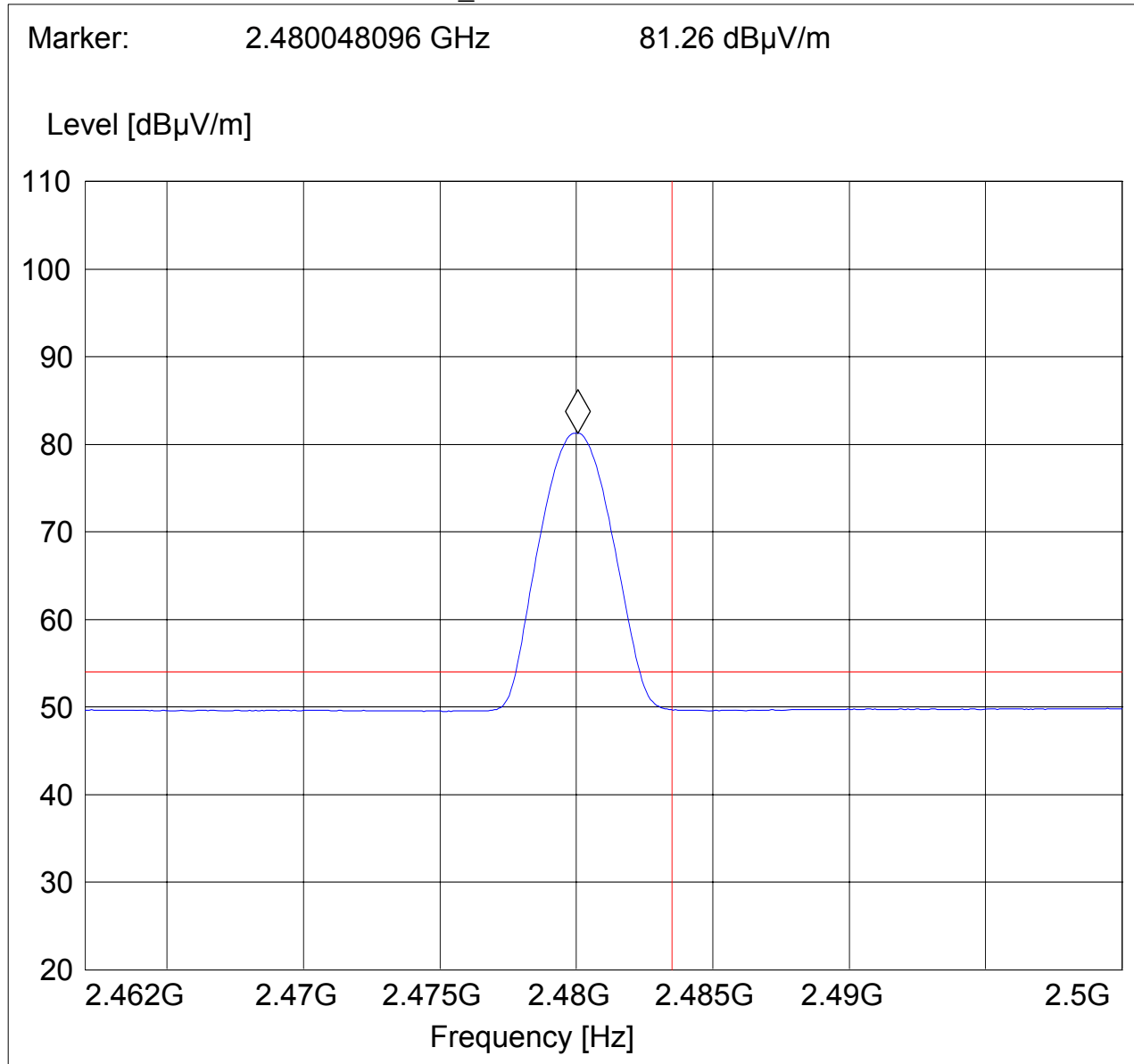



**3.2.4 RESULTS: GFSK (Antenna: HITACH/ HFS27-SO01)
(2402MHz) LOWER BAND EDGE PEAK -GFSK MODULATION
CETECOM Inc.**

411 Dixon Landing Road, Milpitas CA 95035, USA

EUT: USB Bluetooth Module
Customer: Broadcom
Test Mode: BT CH 0, Modulation: GFSK
ANT Orientation: V
EUT Orientation: V (eut antenna)
Test Engineer: Ed
Power Supply: via USB
Comments: Hitachi antenna

SWEEP TABLE: "FCC15.247 LBE_PK"

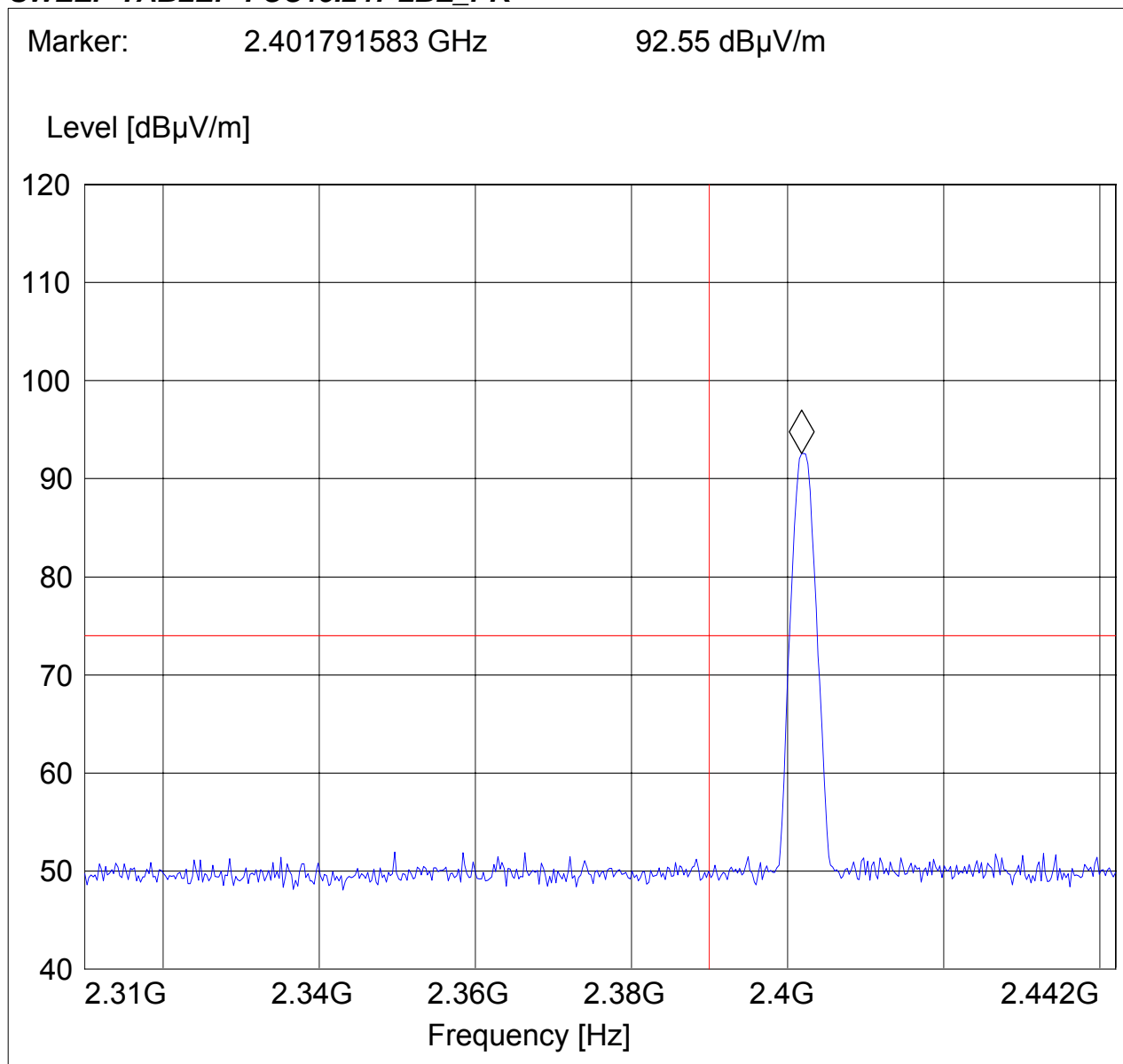



(2402MHz) LOWER BAND EDGE AVERAGE -GFSK MODULATION

CETECOM Inc.

411 Dixon Landing Road, Milpitas CA 95035, USA

EUT: USB Bluetooth Module

Customer: Broadcom

Test Mode: BT CH 0, Modulation: GFSK

ANT Orientation: V

EUT Orientation: V (eut antenna)

Test Engineer: Ed

Power Supply:: via USB

Comments: Hitachi antenna

SWEEP TABLE: "FCC15.247

LBE_AVG"

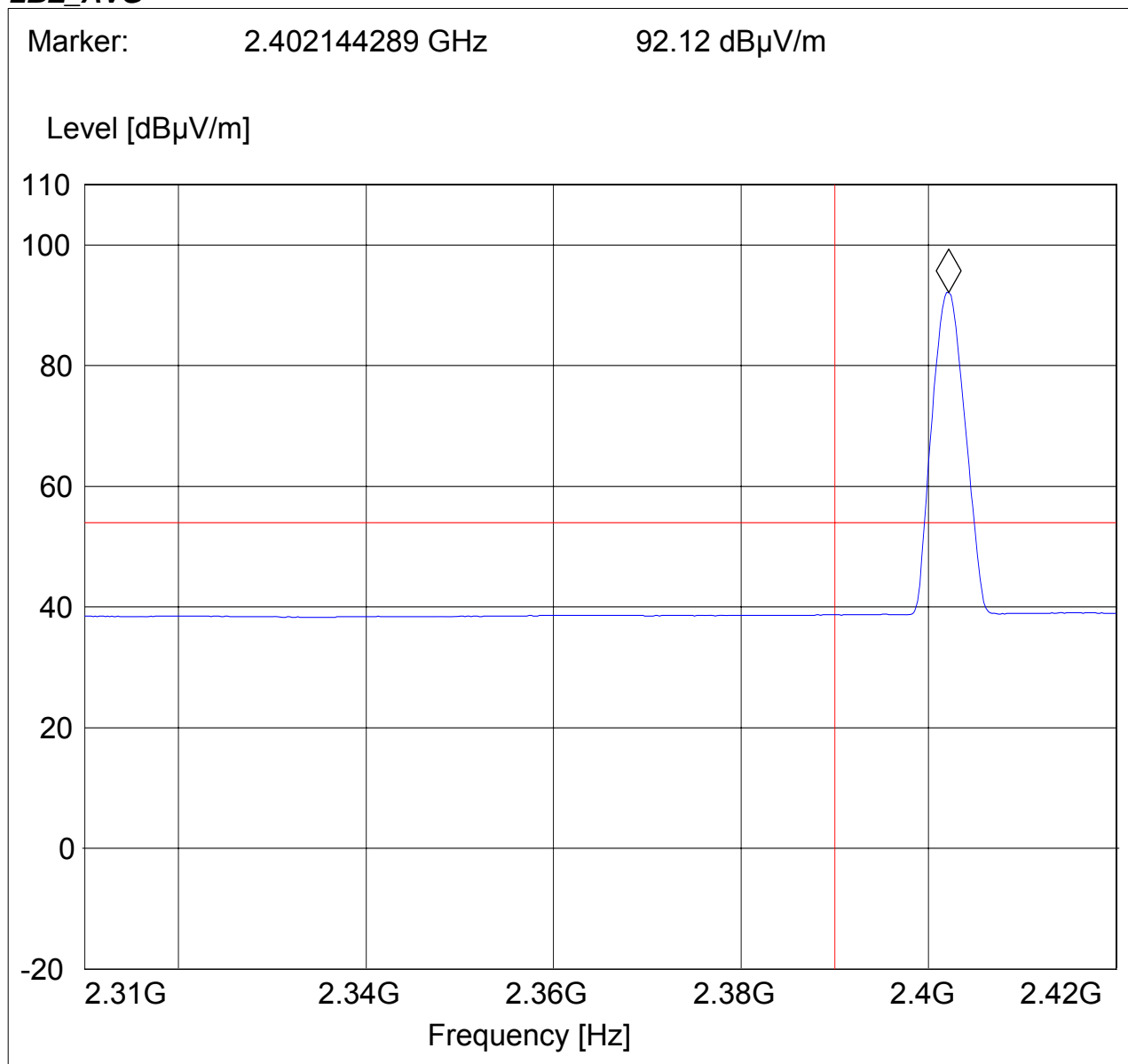



(2480MHz) HIGHER BAND EDGE PEAK -GFSK MODULATION

CETECOM Inc.

411 Dixon Landing Road, Milpitas CA 95035, USA

EUT: USB Bluetooth Module

Customer: Broadcom

Test Mode: BT CH 78, Modulation: GFSK

ANT Orientation: V

EUT Orientation: V (eut antenna)

Test Engineer: Ed

Power Supply:: via USB

Comments: Hitachi antenna

SWEEP TABLE: "FCC15.247 HBE_PK"

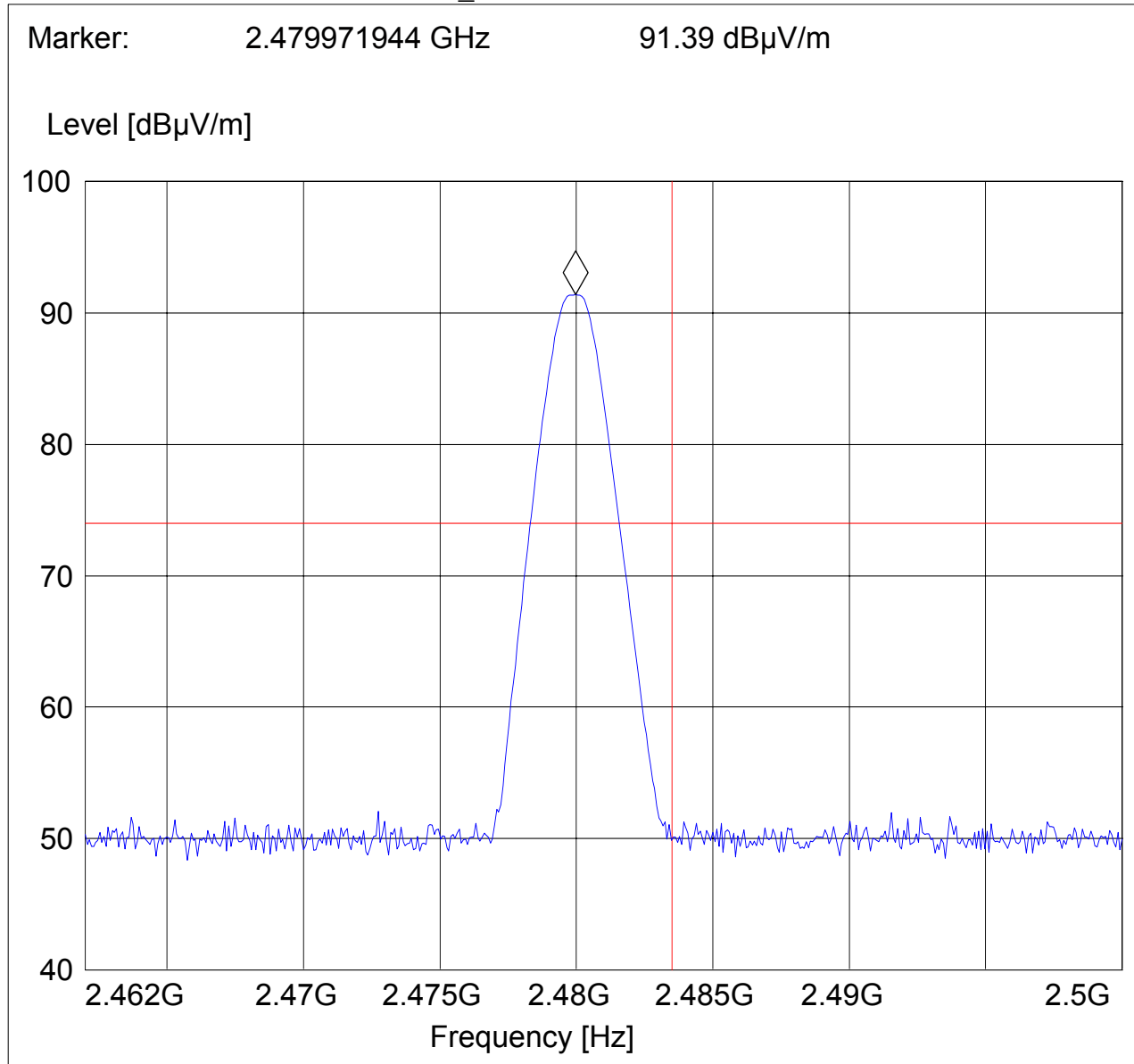



HIGHER BAND EDGE AVERAGE-GFSK MODULATION

CETECOM Inc.

411 Dixon Landing Road, Milpitas CA 95035, USA

EUT: USB Bluetooth Module

Customer: Broadcom

Test Mode: BT CH 78, Modulation: GFSK

ANT Orientation: V

EUT Orientation: V (eut antenna)

Test Engineer: Ed

Power Supply: via USB

Comments: Hitachi antenna

SWEEP TABLE: "FCC15.247 HBE_AVG"

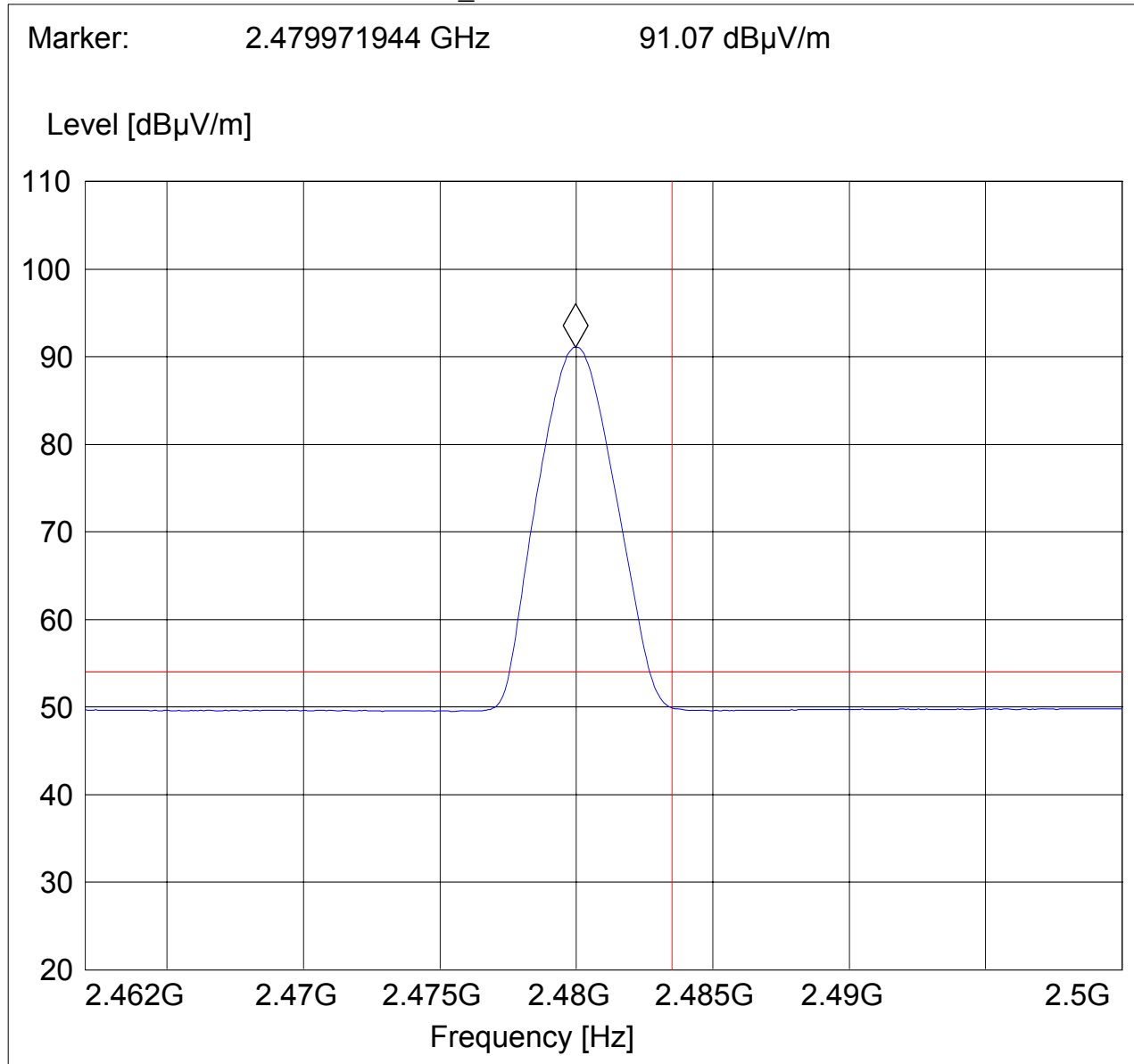



**3.2.5 RESULTS: GFSK (Antenna: HITACH/ HFS27-SO01)
(2402MHz) LOWER BAND EDGE PEAK –8DPSK MODULATION**

CETECOM Inc.

411 Dixon Landing Road, Milpitas CA 95035, USA

EUT: USB Bluetooth Module

Customer: Broadcom

Test Mode: BT CH 0; Modulation: 8DPSK

ANT Orientation: V

EUT Orientation: V (eut antenna)

Test Engineer: Satya Radhakrishna

Power Supply: via USB

Comments: Hitachi antenna

SWEEP TABLE: "FCC15.247 LBE_PK"

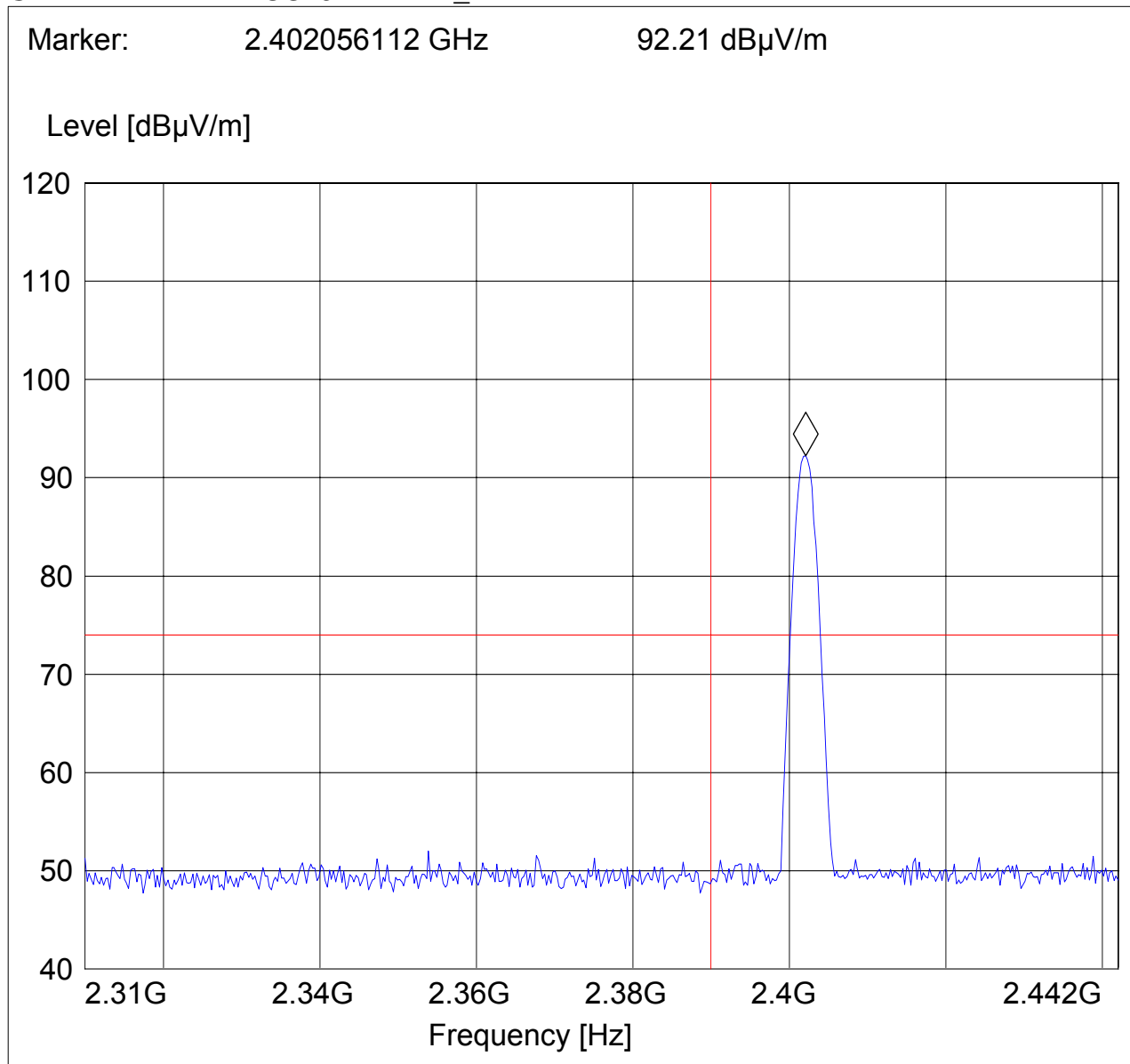



(2402MHz) LOWER BAND EDGE AVERAGE –8DPSK MODULATION

CETECOM Inc.

411 Dixon Landing Road, Milpitas CA 95035, USA

EUT: USB Bluetooth Module

Customer: Broadcom

Test Mode: BT CH 0; Modulation: 8DPSK

ANT Orientation: V

EUT Orientation: V (eut antenna)

Test Engineer: Satya Radhakrishna

Power Supply: via USB

Comments: Hitachi antenna

SWEEP TABLE: "FCC15.247 LBE_AVG"

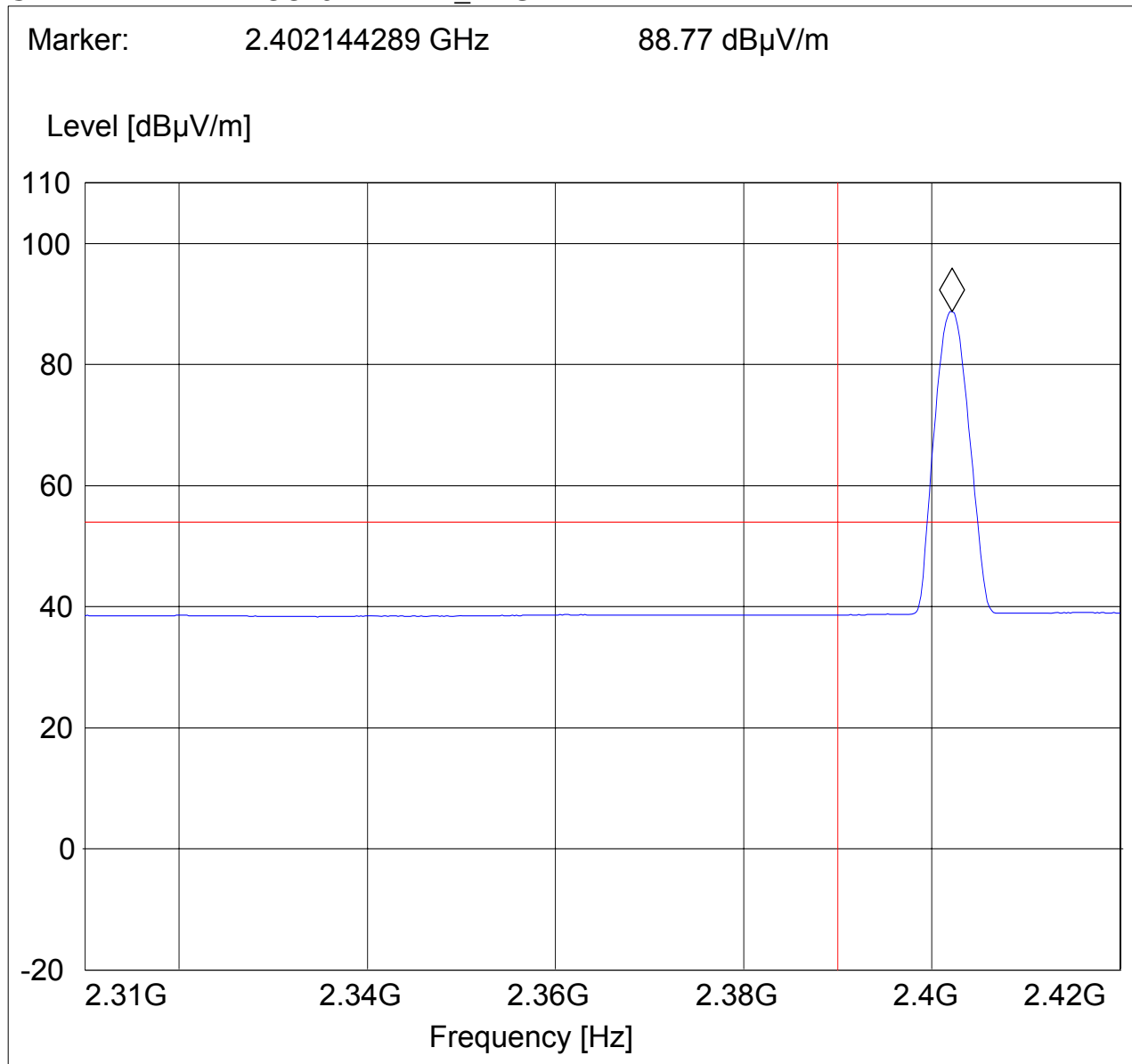



(2480MHz) HIGHER BAND EDGE PEAK –8DPSK MODULATION

CETECOM Inc.

411 Dixon Landing Road, Milpitas CA 95035, USA

EUT: USB Bluetooth Module

Customer: Broadcom

Test Mode: BT CH 78; Modulation: 8DPSK

ANT Orientation: V

EUT Orientation: V (eut antenna)

Test Engineer: Satya Radhakrishna

Power Supply: via USB

Comments: Hitachi antenna

SWEEP TABLE: "FCC15.247 HBE_PK"

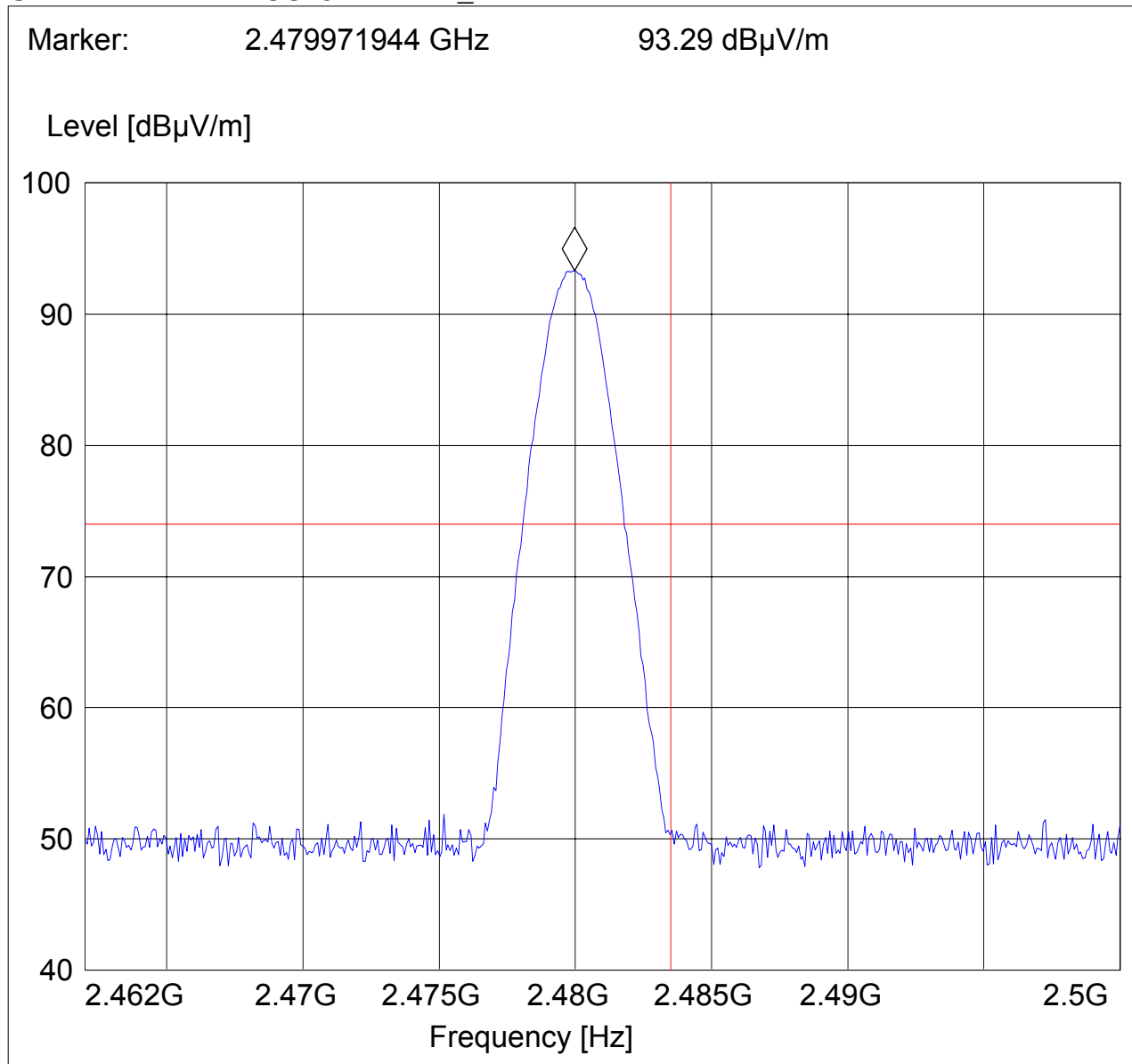



HIGHER BAND EDGE AVERAGE-8DPSK MODULATION

CETECOM Inc.

411 Dixon Landing Road, Milpitas CA 95035, USA

EUT: USB Bluetooth Module

Customer: Broadcom

Test Mode: BT CH 78; Modulation: 8DPSK

ANT Orientation: V

EUT Orientation: V (eut antenna)

Test Engineer: Satya Radhakrishna

Power Supply: via USB

Comments: Hitachi antenna

SWEEP TABLE: "FCC15.247 HBE_AVG"

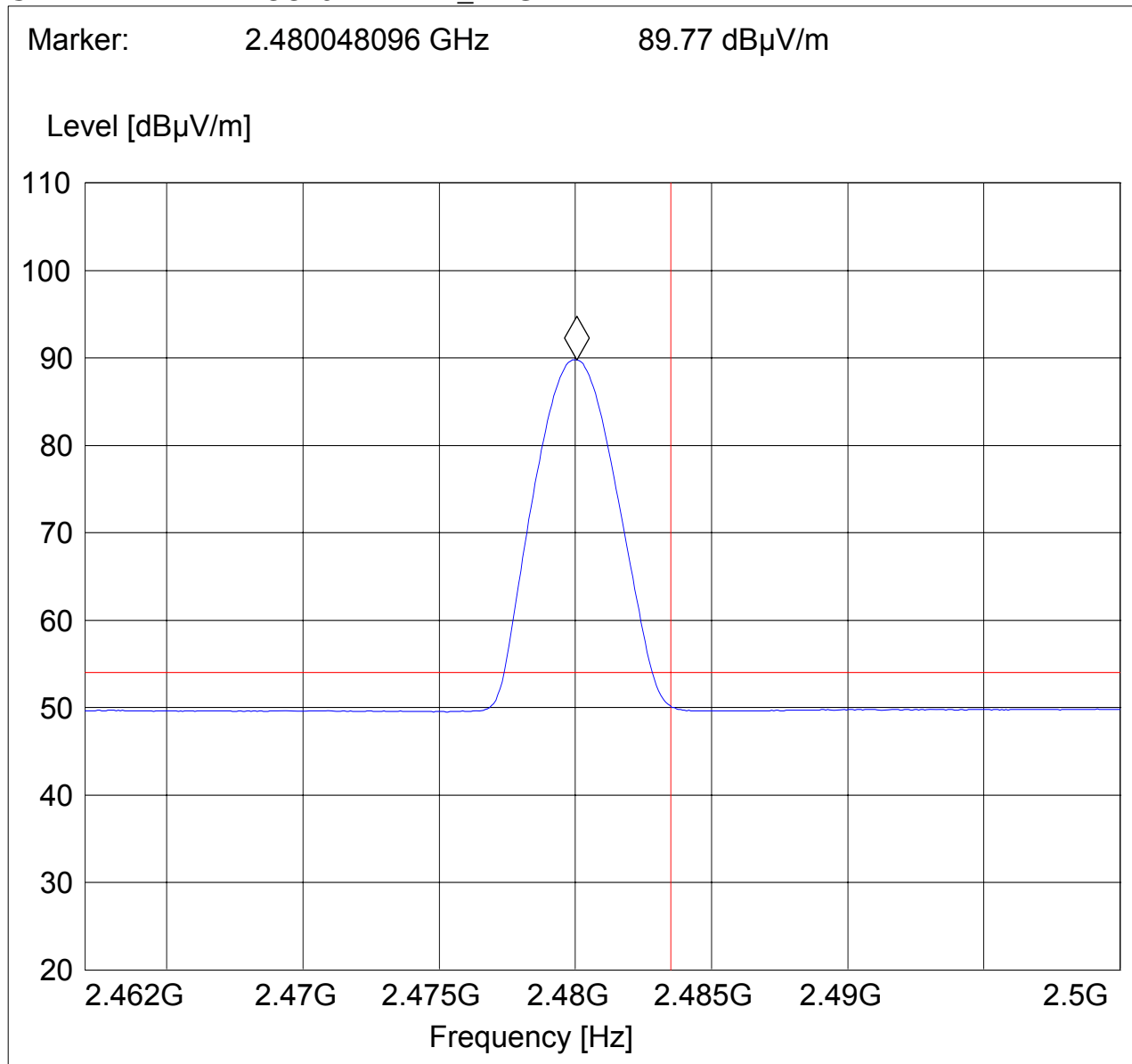



3.3 TRANSMITTER SPURIOUS EMISSIONS RADIATED § 15.247/15.205/15.209

3.3.1 LIMITS

(a) Except as shown in paragraph (d) of this section, only spurious emissions are permitted in any of the frequency bands listed below:

MHz	MHz	MHz	GHz
0.090 - 0.110	16.42 - 16.423	399.9 - 410	4.5 - 5.15
¹ 0.495 - 0.505	16.69475 - 16.69525	608 - 614	5.35 - 5.46
2.1735 - 2.1905	16.80425 - 16.80475	960 - 1240	7.25 - 7.75
4.125 - 4.128	25.5 - 25.67	1300 - 1427	8.025 - 8.5
4.17725 - 4.17775	37.5 - 38.25	1435 - 1626.5	9.0 - 9.2
4.20725 - 4.20775	73 - 74.6	1645.5 - 1646.5	9.3 - 9.5
6.215 - 6.218	74.8 - 75.2	1660 - 1710	10.6 - 12.7
6.26775 - 6.26825	108 - 121.94	1718.8 - 1722.2	13.25 - 13.4
6.31175 - 6.31225	123 - 138	2200 - 2300	14.47 - 14.5
8.291 - 8.294	149.9 - 150.05	2310 - 2390	15.35 - 16.2
8.362 - 8.366	156.52475 - 156.52525	2483.5 - 2500	17.7 - 21.4
8.37625 - 8.38675	156.7 - 156.9	2690 - 2900	22.01 - 23.12
8.41425 - 8.41475	162.0125 - 167.17	3260 - 3267	23.6 - 24.0
12.29 - 12.293	167.72 - 173.2	3332 - 3339	31.2 - 31.8
12.51975 - 12.52025	240 - 285	3345.8 - 3358	36.43 - 36.5
12.57675 - 12.57725	322 - 335.4	3600 - 4400	(²)
13.36 - 13.41			

*PEAK LIMIT= 74dBuV/m

*AVG. LIMIT= 54dBuV/m

NOTE:

1. The radiated emissions were done with different settings, using the relevant pre-amplifiers for the relevant frequency ranges. This is the reason that the graphs show different noise levels. In the range between 3 and 25 GHz very short cable connections to the antenna was used to minimize the noise level.
2. All measurements are done in peak mode using an average limit , unless specified with the plots.
3. Measurements were performed with both the WHA YU/C680-520022-A antenna and HITACH/HFS27-SO01 antenna with both GFSK and 8DPSK. The worst case emissions were with the WHA YU/C680-520022-A antenna with 8DPSK. Emissions shown below are worst case emissions.

Results for the radiated measurements below 30MHz according § 15.33

Frequency	Measured values	Remarks
9KHz – 30MHz	No emissions found, caused by the EUT	This is valid for all the tested channels



3.3.2 RESULTS

30MHz – 1GHz

Note: This plot is valid for low, mid, high channels (worst-case plot)

CETECOM Inc.

411 Dixon Landing Road, Milpitas CA 95035, USA

EUT: USB Bluetooth Module

Customer: Broadcom

Test Mode: BT CH 0; Modulation: 8PSK

ANT Orientation: V

EUT Orientation: V (eut antenna)

Test Engineer: Ed

Power Supply: via USB

Comments: Stump metal antenna

SWEEP TABLE: "FCC15.247_30M-1G_Ver"

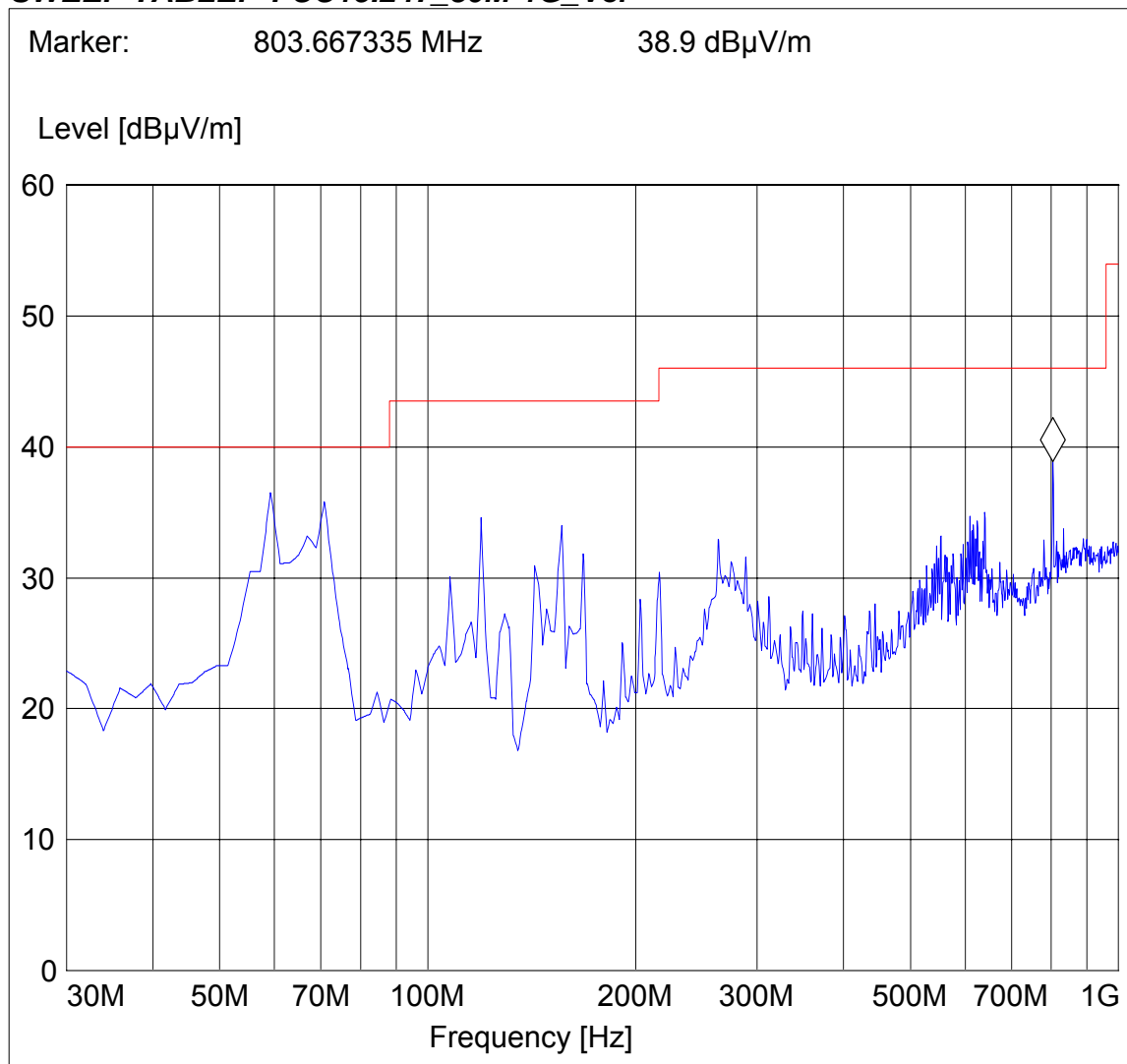



1-3GHz (2402MHz)

Note: The peak above the limit line is the carrier freq.

Note: Peak Reading vs. Average limit

CETECOM Inc.

411 Dixon Landing Road, Milpitas CA 95035, USA

EUT: USB Bluetooth Module

Customer: Broadcom

Test Mode: BT CH 0, Modulation: 8DPSK

ANT Orientation: V

EUT Orientation: V (eut antenna)

Test Engineer: Ed

Power Supply: via USB

Comments: Stump metal antenna

SWEEP TABLE: "FCC15.247_1-3G"

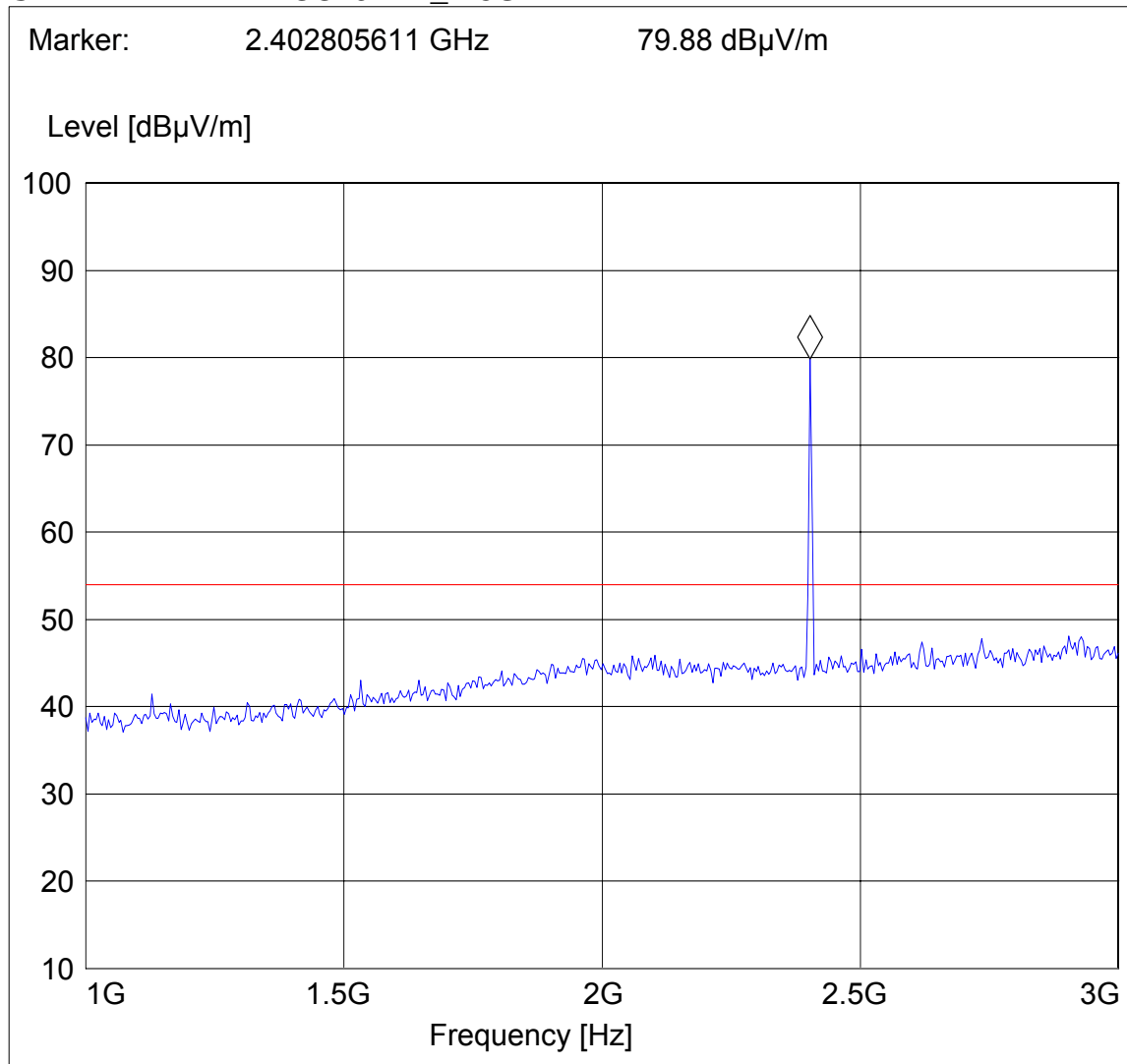



3-18GHz (2402MHz)

Note: Peak Reading vs. Average limit

CETECOM Inc.

411 Dixon Landing Road, Milpitas CA 95035, USA

EUT: USB Bluetooth Module

Customer: Broadcom

Test Mode: BT CH 0, Modulation: 8DPSK

ANT Orientation: V

EUT Orientation: V (eut antenna)

Test Engineer: Ed

Power Supply: via USB

Comments: Stump metal antenna

SWEEP TABLE: "FCC15.247_3-18G"

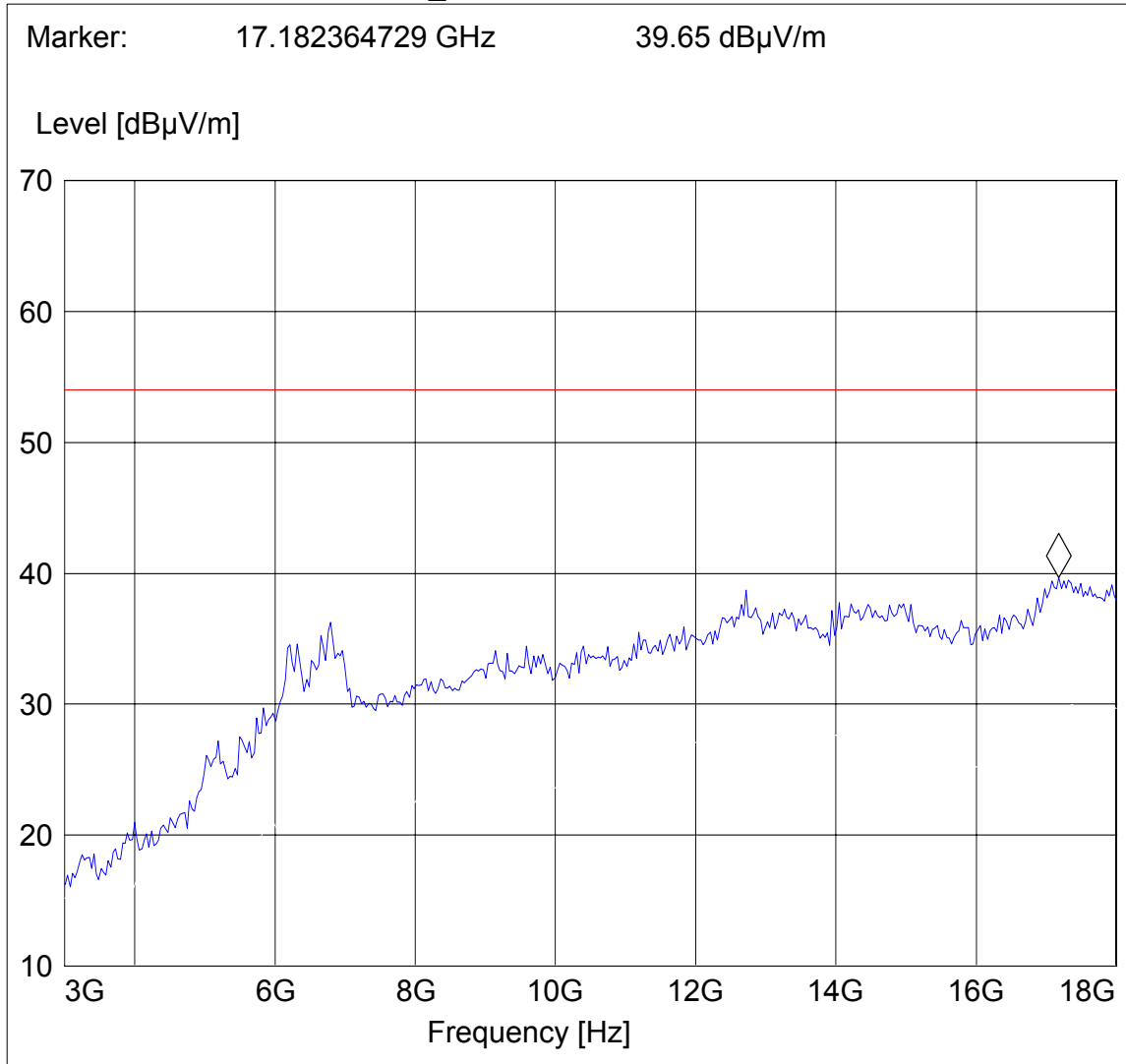



1-3GHz (2441MHz)

Note: The peaks above the limit line is the carrier freq.

Note: Peak Reading vs. Average limit

CETECOM Inc.

411 Dixon Landing Road, Milpitas CA 95035, USA

EUT: USB Bluetooth Module

Customer: Broadcom

Test Mode: BT CH 39, Modulation: 8DPSK

ANT Orientation: V

EUT Orientation: V (eut antenna)

Test Engineer: Ed

Power Supply:: via USB

Comments: Stump metal antenna

SWEEP TABLE: "FCC15.247_1-3G"

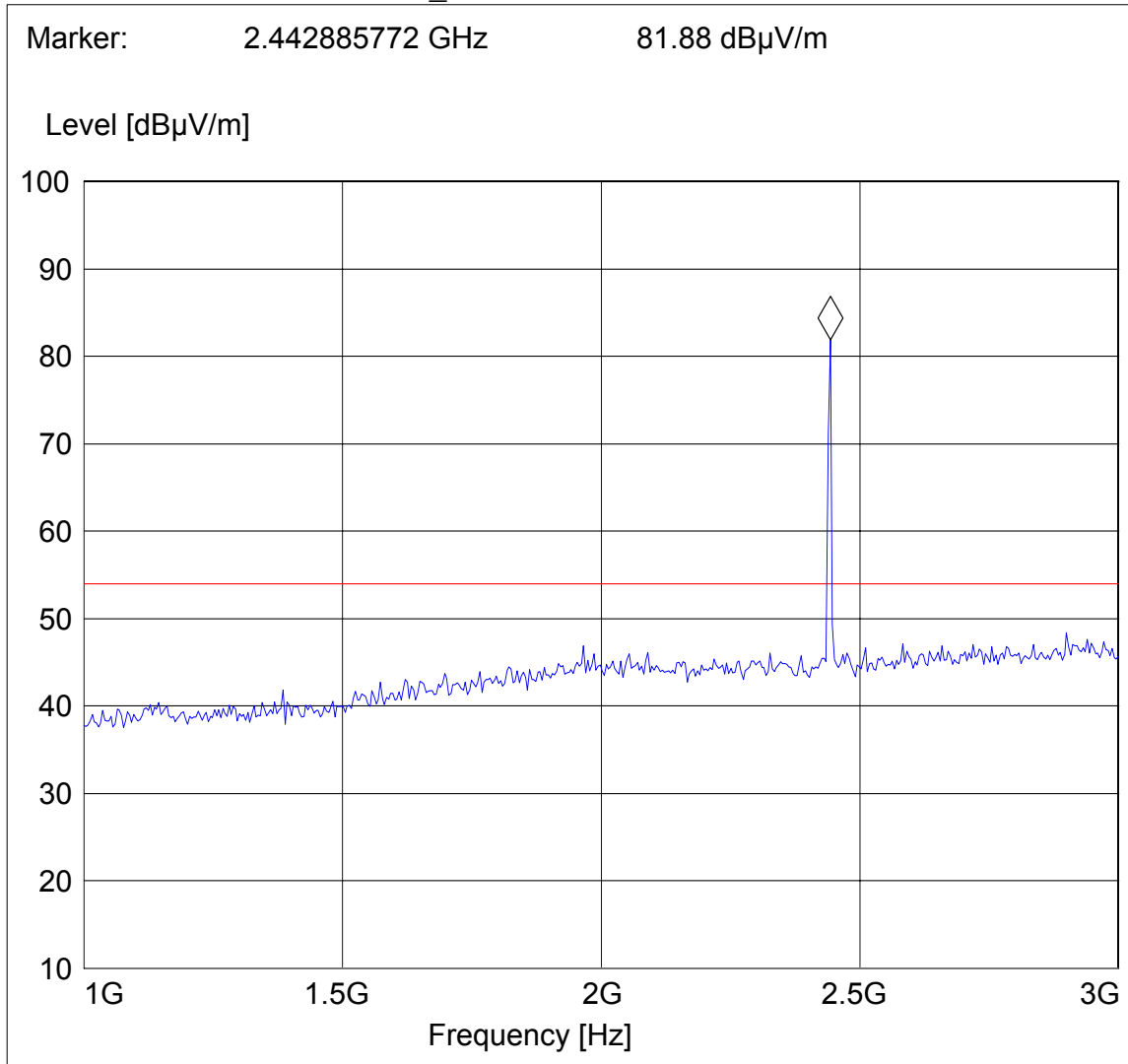



3-18GHz (2441MHz)

Note: Peak Reading vs. Average limit

CETECOM Inc.

411 Dixon Landing Road, Milpitas CA 95035, USA

EUT: USB Bluetooth Module

Customer: Broadcom

Test Mode: BT CH 39, Modulation: 8DPSK

ANT Orientation: V

EUT Orientation: V (eut antenna)

Test Engineer: Ed

Power Supply: via USB

Comments: Stump metal antenna

SWEEP TABLE: "FCC15.247_3-18G"

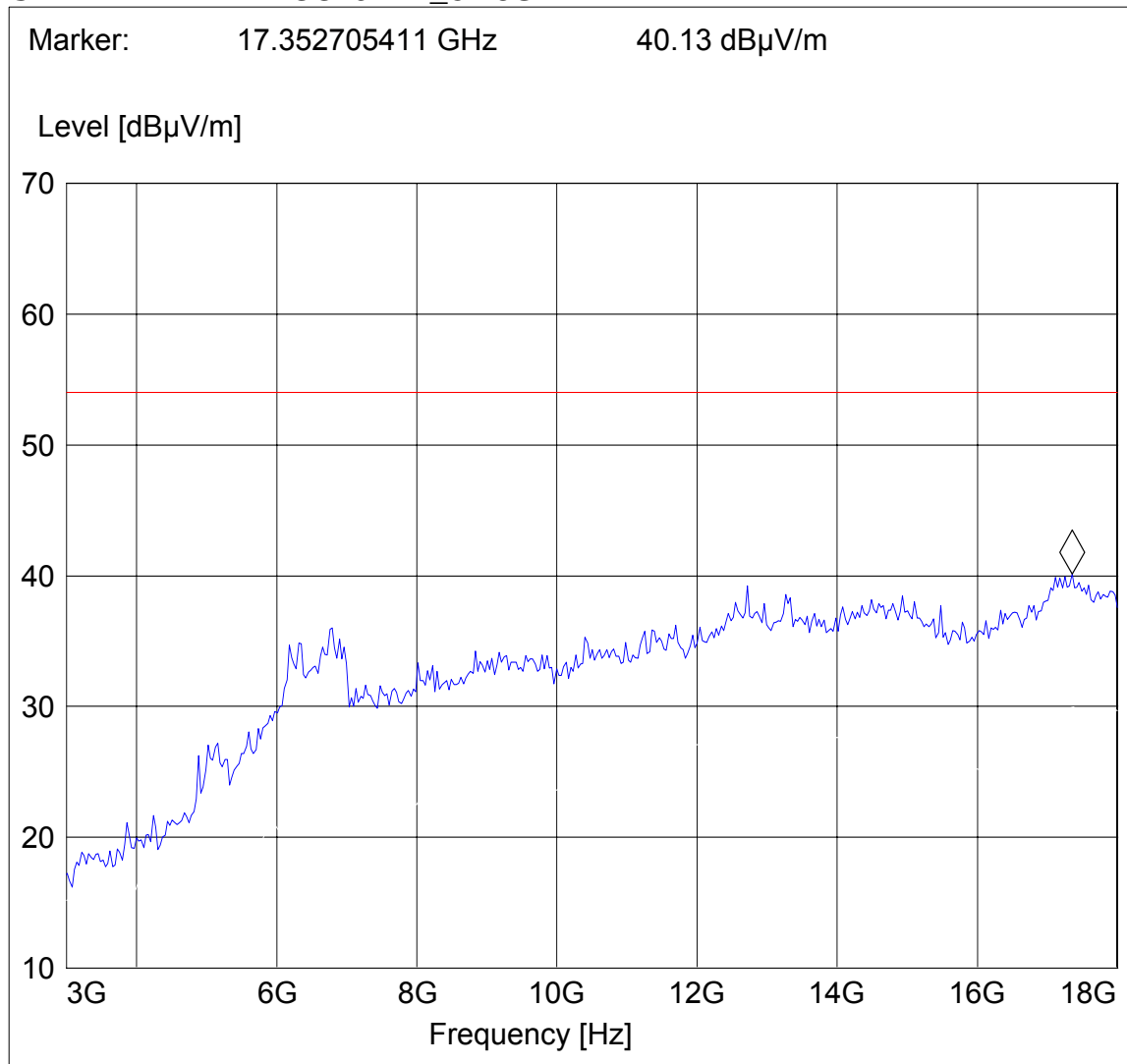

Test Report #: BROAD_031_01001_15.247BT

Date of Report : 2007-05-16

Page 31 of 65



1-3GHz (2480MHz)

Note: The peaks above the limit line is the carrier freq.

Note: Peak Reading vs. Average limit

CETECOM Inc.

411 Dixon Landing Road, Milpitas CA 95035, USA

EUT: USB Bluetooth Module

Customer: Broadcom

Test Mode: BT CH 78, Modulation: 8DPSK

ANT Orientation: V

EUT Orientation: V (eut antenna)

Test Engineer: Ed

Power Supply:: via USB

Comments: Stump metal antenna

SWEEP TABLE: "FCC15.247_1-3G"

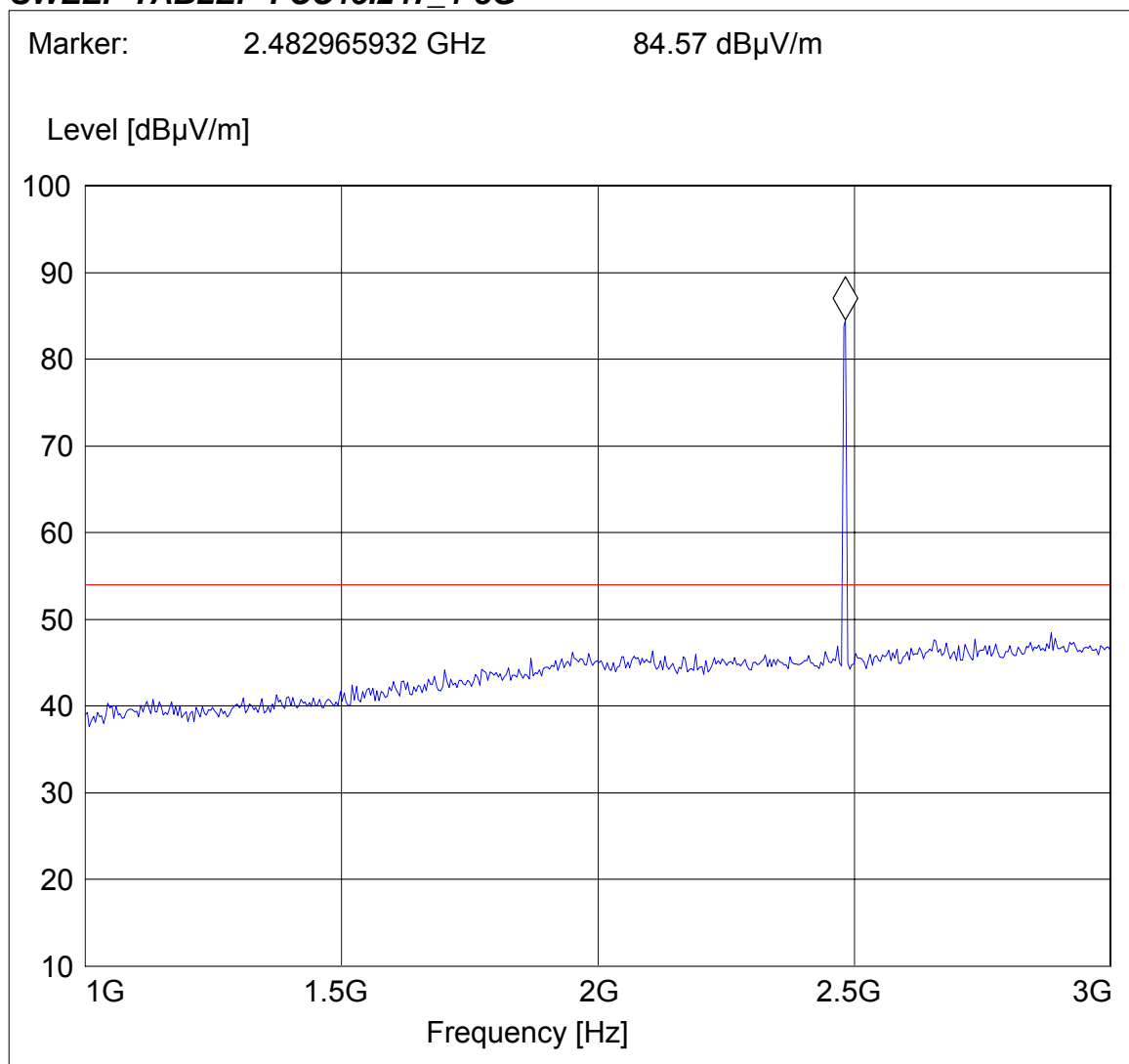



3-18GHz (2480MHz)

Note: Peak Reading vs. Average limit

CETECOM Inc.

411 Dixon Landing Road, Milpitas CA 95035, USA

EUT: USB Bluetooth Module

Customer: Broadcom

Test Mode: BT CH 78, Modulation: 8DPSK

ANT Orientation: V

EUT Orientation: V (eut antenna)

Test Engineer: Ed

Power Supply: via USB

Comments: Stump metal antenna

SWEEP TABLE: "FCC15.247_3-18G"

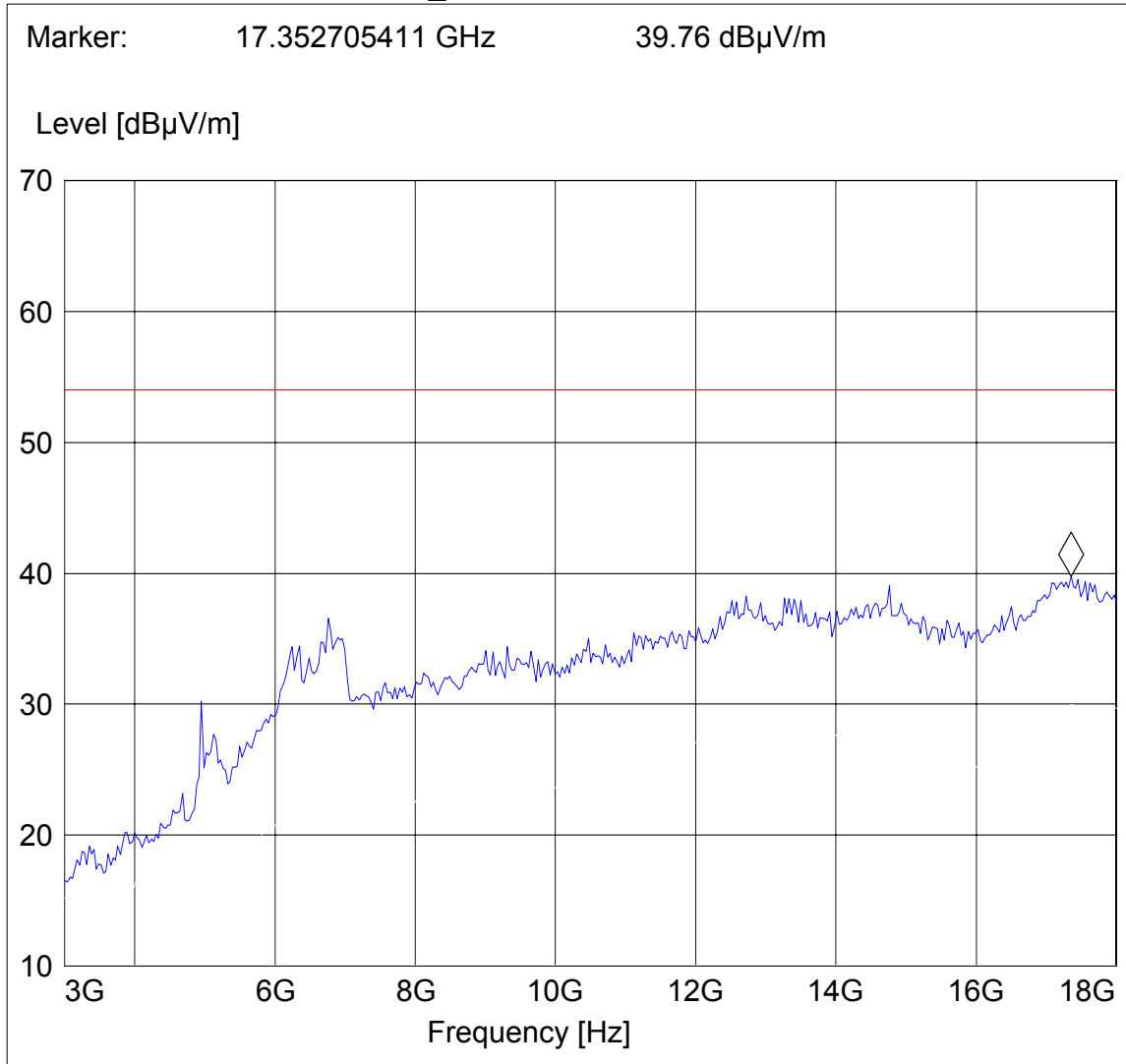



18-25GHz

Note: This plot is valid for low, mid, high channels (worst-case plot)

Note: Peak Reading vs. Average limit

CETECOM Inc.

411 Dixon Landing Road, Milpitas CA 95035, USA

EUT: USB Bluetooth Module

Customer: Broadcom

Test Mode: BT CH 0, Modulation: 8DPSK

ANT Orientation: V

EUT Orientation: V (eut antenna)

Test Engineer: Ed

Power Supply:: via USB

Comments: Stump metal antenna

SWEEP TABLE: "FCC15.247_18-26.5G"

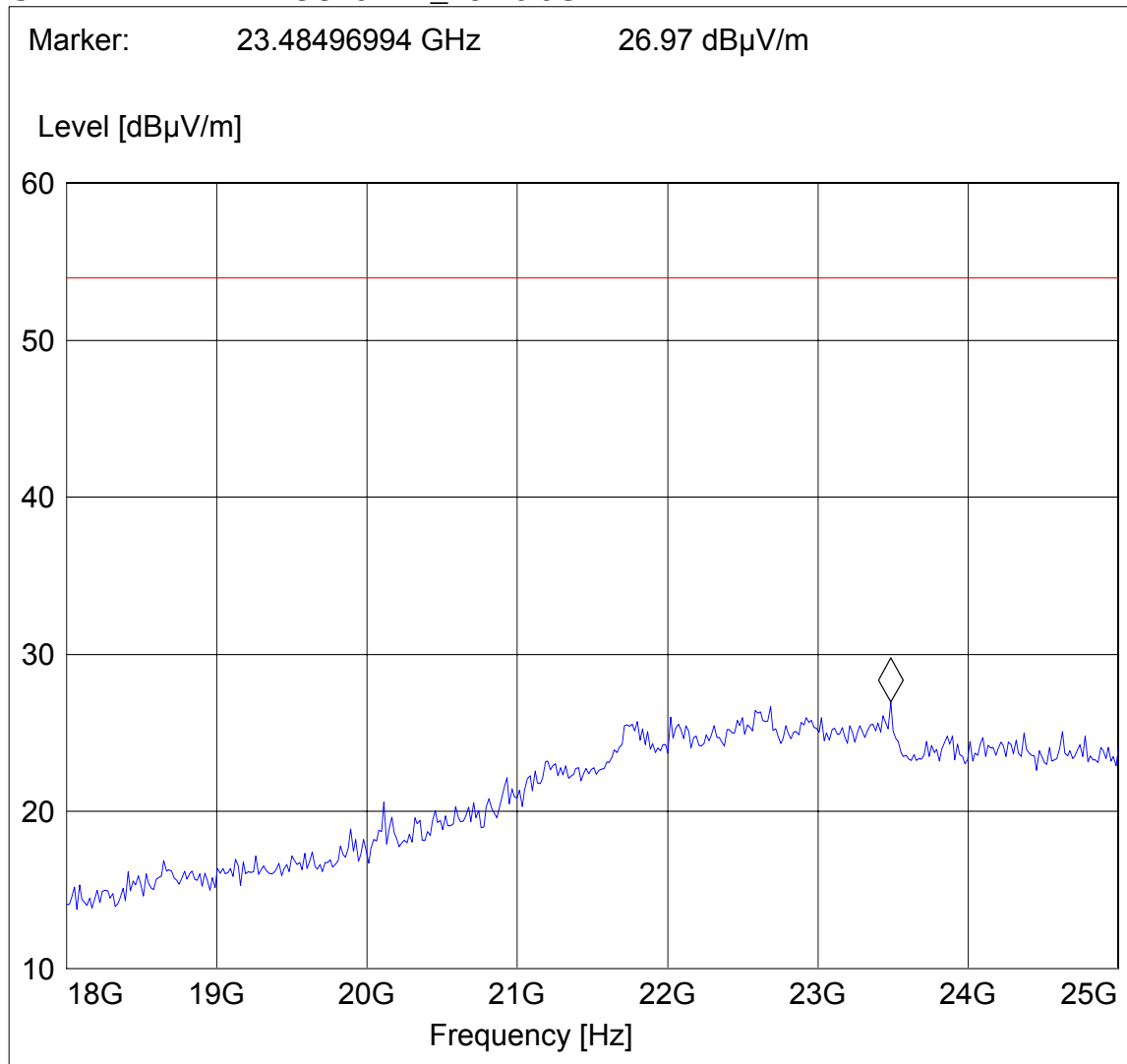



3.4 RECEIVER SPURIOUS RADIATION § 15.209/RSS210

3.4.1 LIMITS

Frequency (MHz)	Field strength ($\mu\text{V/m}$)	Measurement distance (m)
0.009 - 0.490	2400/F (kHz)	300
0.490 - 1.705	2400/F (kHz)	30
1.705 - 30.0	30	30
30 - 88	100	3
88 - 216	150	3
216 - 960	200	3
above 960	500	3

NOTE:

1. The radiated emissions were done with different settings, using the relevant pre-amplifiers for the relevant frequency ranges. This is the reason that the graphs show different noise levels. In the range between 3 and 25 GHz very short cable connections to the antenna was used to minimize the noise level.
2. All measurements are done in peak mode using a quasi peak or average limit , unless specified with the plots.
3. Measurements were performed with both the WHA YU/C680-520022-A antenna and HITACH/HFS27-SO01 antenna with both GFSK and 8PSK. The worst case emissions were with the WHA YU/C680-520022-A antenna with 8DPSK. Emissions shown below are worst case emissions.



3.4.2 RESULTS

30MHz – 1GHz

Note: This plot is valid for all polarizations and low, mid, high channels (worst-case plot)

Note: Peak Reading vs. Quasi-peak limit

CETECOM Inc.

411 Dixon Landing Road, Milpitas CA 95035, USA

EUT: USB Bluetooth Module

Customer: Broadcom

Test Mode: BT CH 39; Receive Mode

ANT Orientation: V

EUT Orientation: V (eut antenna)

Test Engineer: Ed

Power Supply: via USB

Comments: Stump metal antenna

SWEEP TABLE: "CANADA RE_30M-1G_Ver"

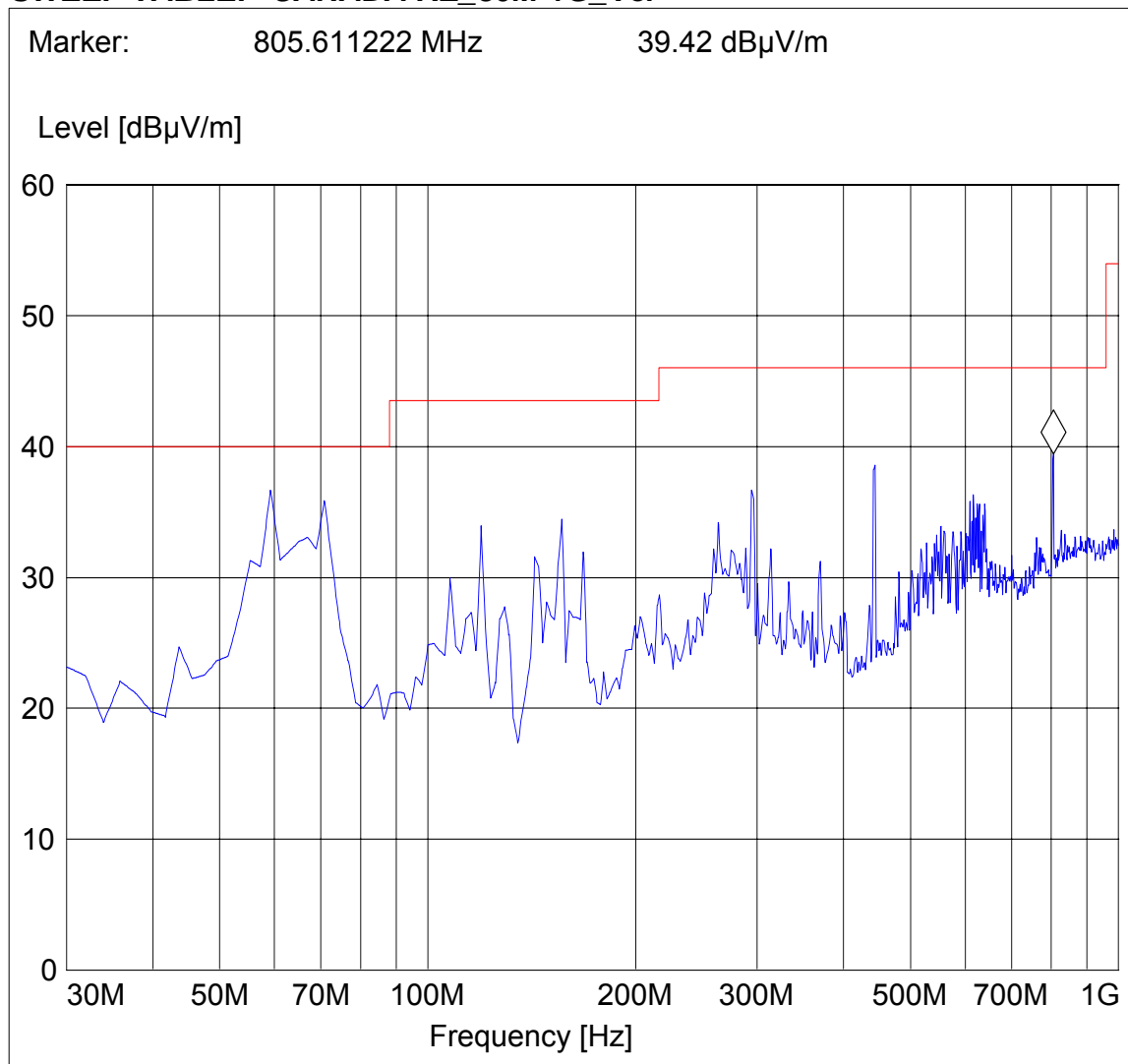



1-3 GHz

Note: Peak Reading vs. Average limit

CETECOM Inc.

411 Dixon Landing Road, Milpitas CA 95035, USA

EUT: USB Bluetooth Module
Customer: Broadcom
Test Mode: BT CH 39, receive mode
ANT Orientation: V
EUT Orientation: V (eut antenna)
Test Engineer: Ed
Power Supply: via USB
Comments: Stump metal antenna

SWEEP TABLE: "CANADA RE_1-3G"

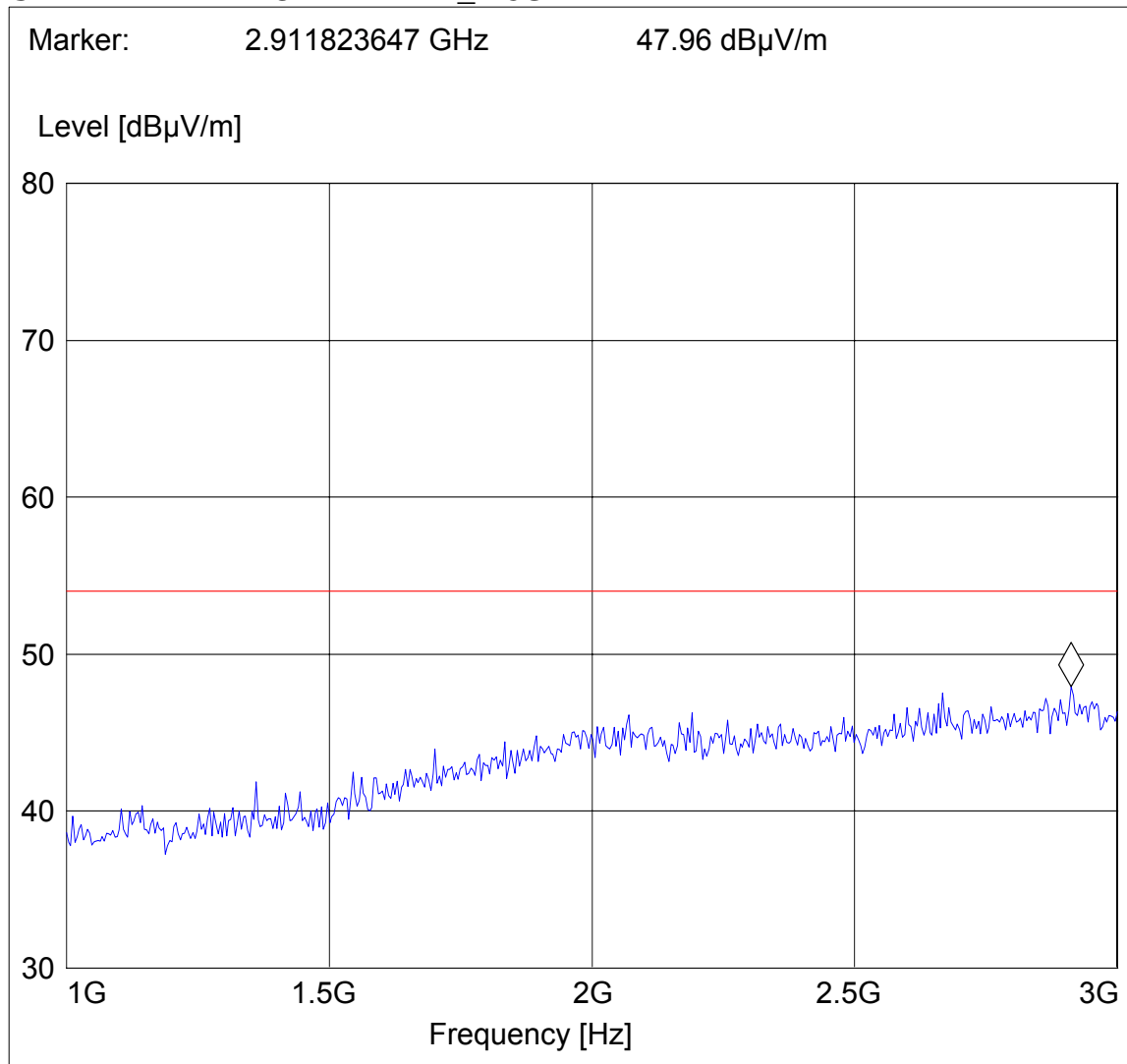



3-18GHz

Note: Peak Reading vs. Average limit

CETECOM Inc.

411 Dixon Landing Road, Milpitas CA 95035, USA

EUT: USB Bluetooth Module

Customer: Broadcom

Test Mode: BT CH 39, receive mode

ANT Orientation: V

EUT Orientation: V (eut antenna)

Test Engineer: Ed

Power Supply: via USB

Comments: Stump metal antenna

SWEEP TABLE: "CANADA RE_3-18G"

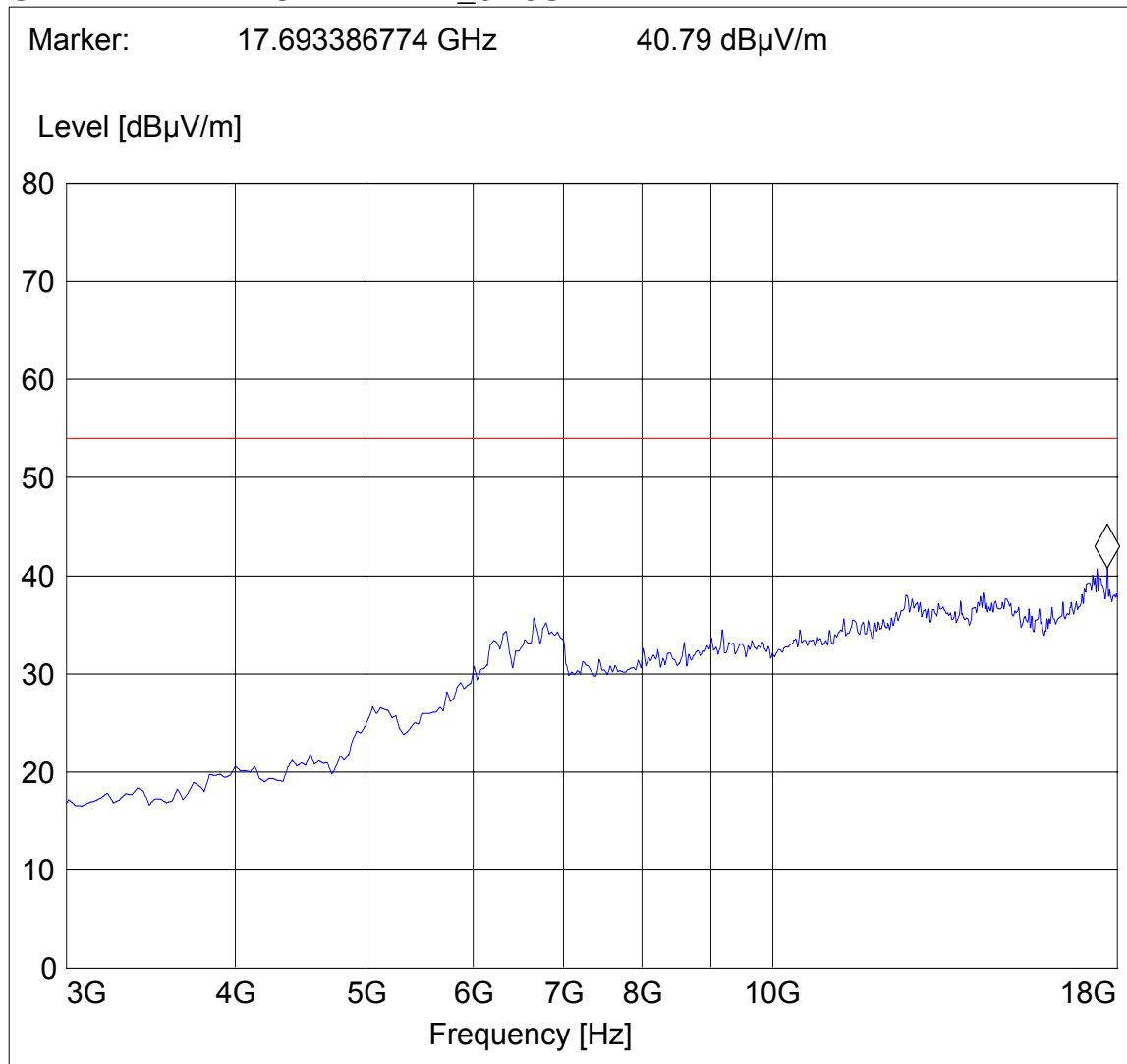



18-25GHz

Note: Peak Reading vs. Average limit

CETECOM Inc.

411 Dixon Landing Road, Milpitas CA 95035, USA

EUT: USB Bluetooth Module

Customer: Broadcom

Test Mode: BT CH 39, receive mode

ANT Orientation: V

EUT Orientation: V (eut antenna)

Test Engineer: Ed

Power Supply: via USB

Comments: Stump metal antenna

SWEEP TABLE: "CANADA RE_18-26.5G"

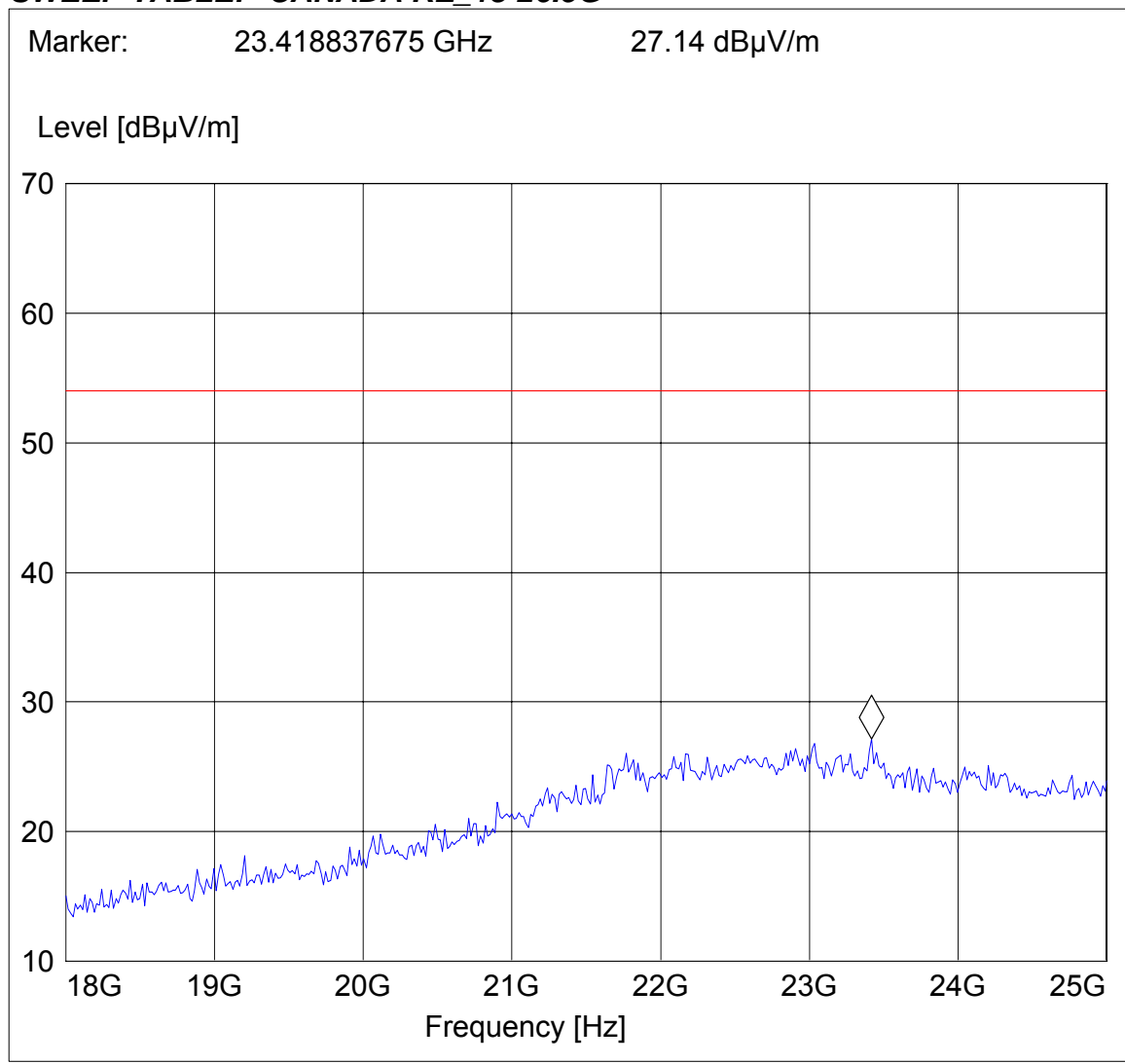



4 Measurements (CONDUCTED)

4.1 MAXIMUM PEAK OUTPUT POWER § 15.247 (CONDUCTED)

4.1.1 LIMIT SUB CLAUSE § 15.247 (b) (1)

Frequency range	RF power output
2400-2483.5 MHz	30dBm

*limit is based upon antenna gain of less than or equal to 6dBi.

TEST CONDITIONS	MAXIMUM PEAK OUTPUT POWER (dBm)		
Frequency (MHz)	2402	2440	2480
GFSK	0.77	1.67	1.41
8PSK	3.16	4.36	3.71
Measurement uncertainty	±0.5dBm		



PEAK OUTPUT POWER (CONDUCTED)

§15.247 (b)

GFSK Lowest Channel: 2402MHz

	Marker 1 [T1]	RBW	3 MHz	RF Att	40 dB
	Ref Lvl	0.77 dBm	VBW	3 MHz	
	11.1 dBm	2.40191483 GHz	SWT	5 ms	Unit dBm

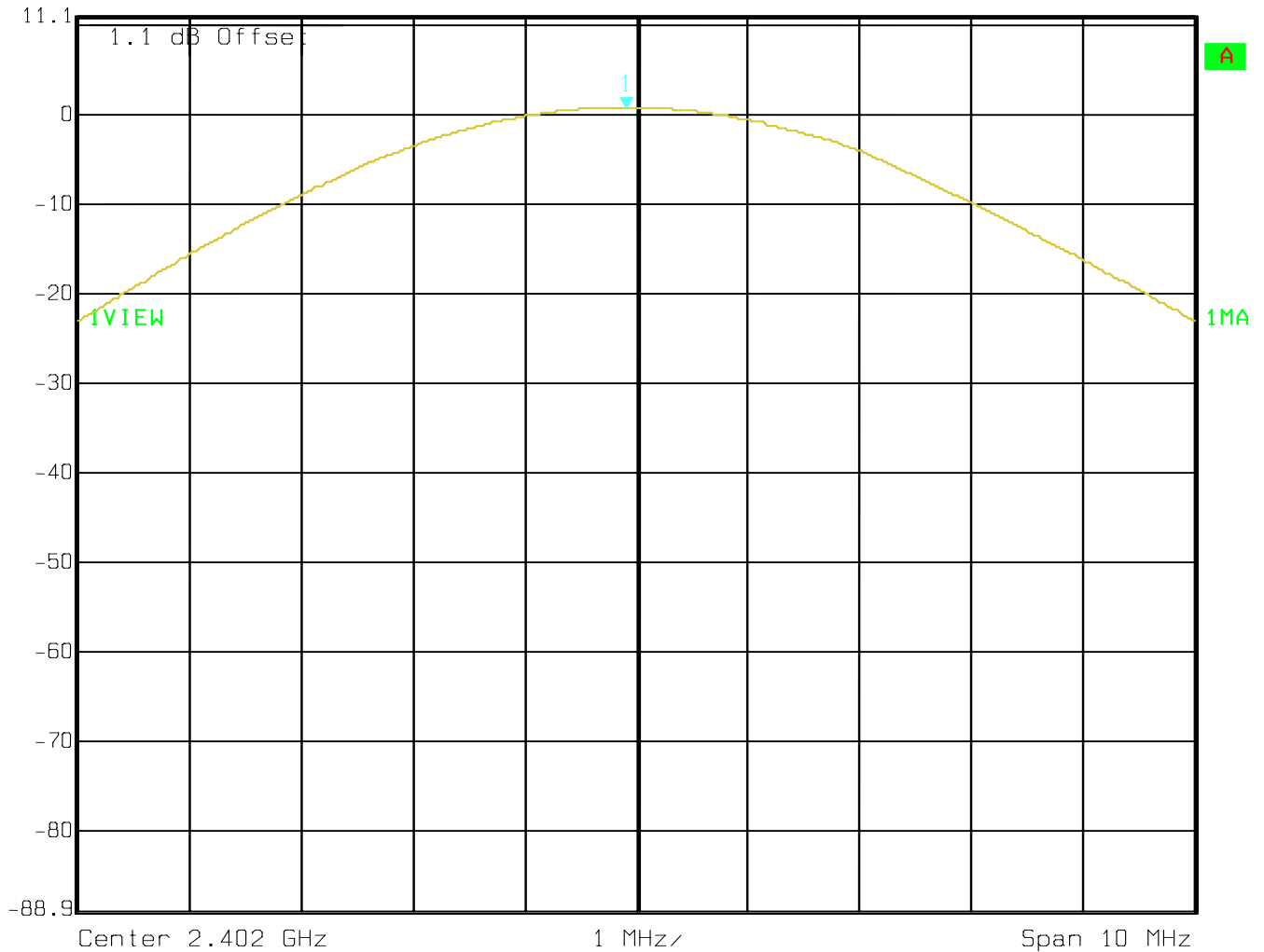

Date: 16.MAY 2007 17:50:29



PEAK OUTPUT POWER (CONDUCTED)

§15.247 (b)

GFSK Mid Channel: 2441MHz



Ref Lvl 11.1 dBm
Marker 1 [T1] 1.67 dBm
2.44090982 GHz
RBW 3 MHz RF Att 40 dB
VBW 3 MHz
SWT 5 ms Unit dBm

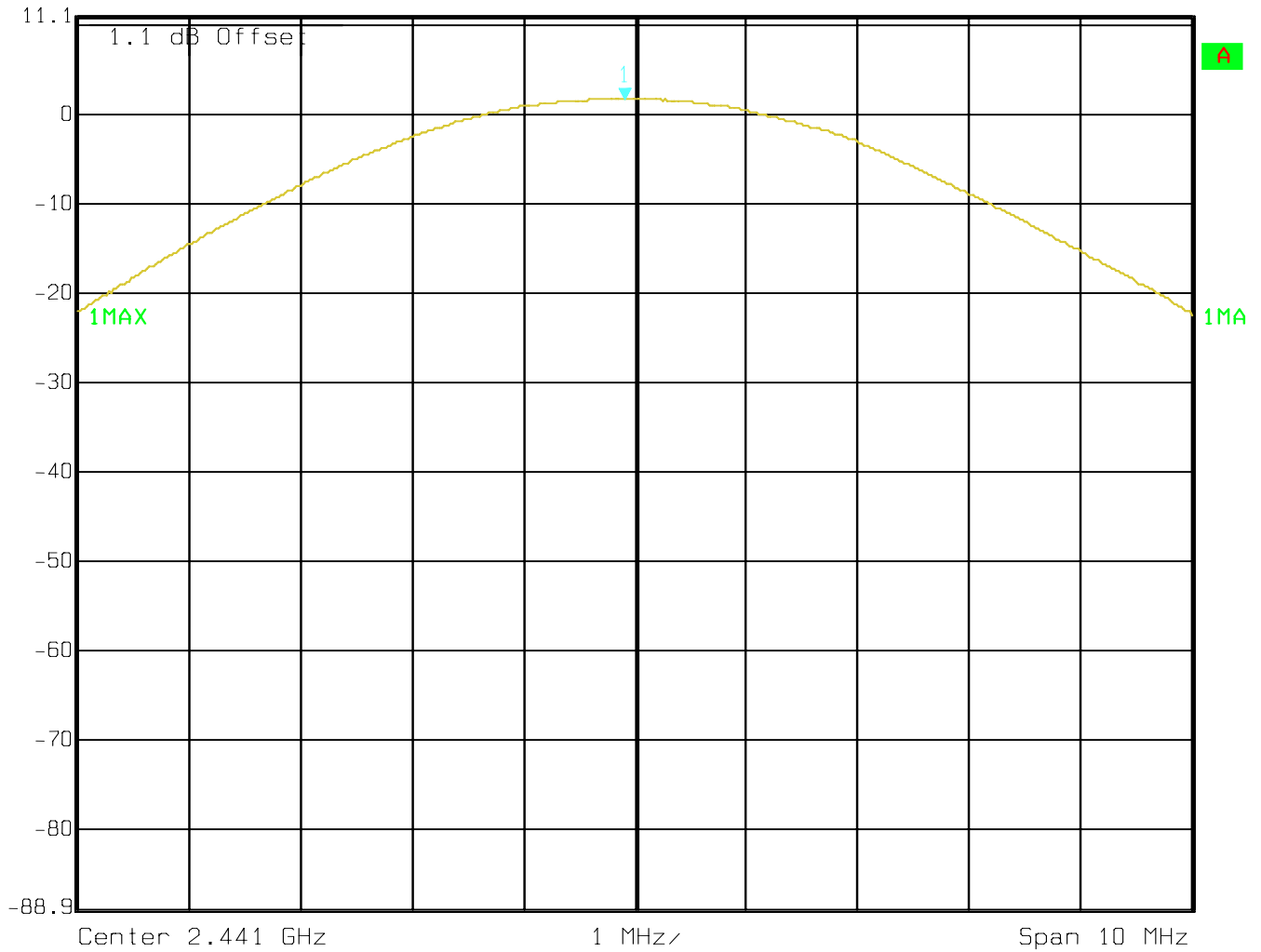

Date: 16.MAY 2007 17:51:09



PEAK OUTPUT POWER (CONDUCTED)

§15.247 (b)

GFSK Highest Channel: 2480MHz

	Marker 1 [T1]	RBW	3 MHz	RF Att	40 dB
	Ref Lvl	1.41 dBm	VBW	3 MHz	
	11.1 dBm	2.47968938 GHz	SWT	5 ms	Unit dBm

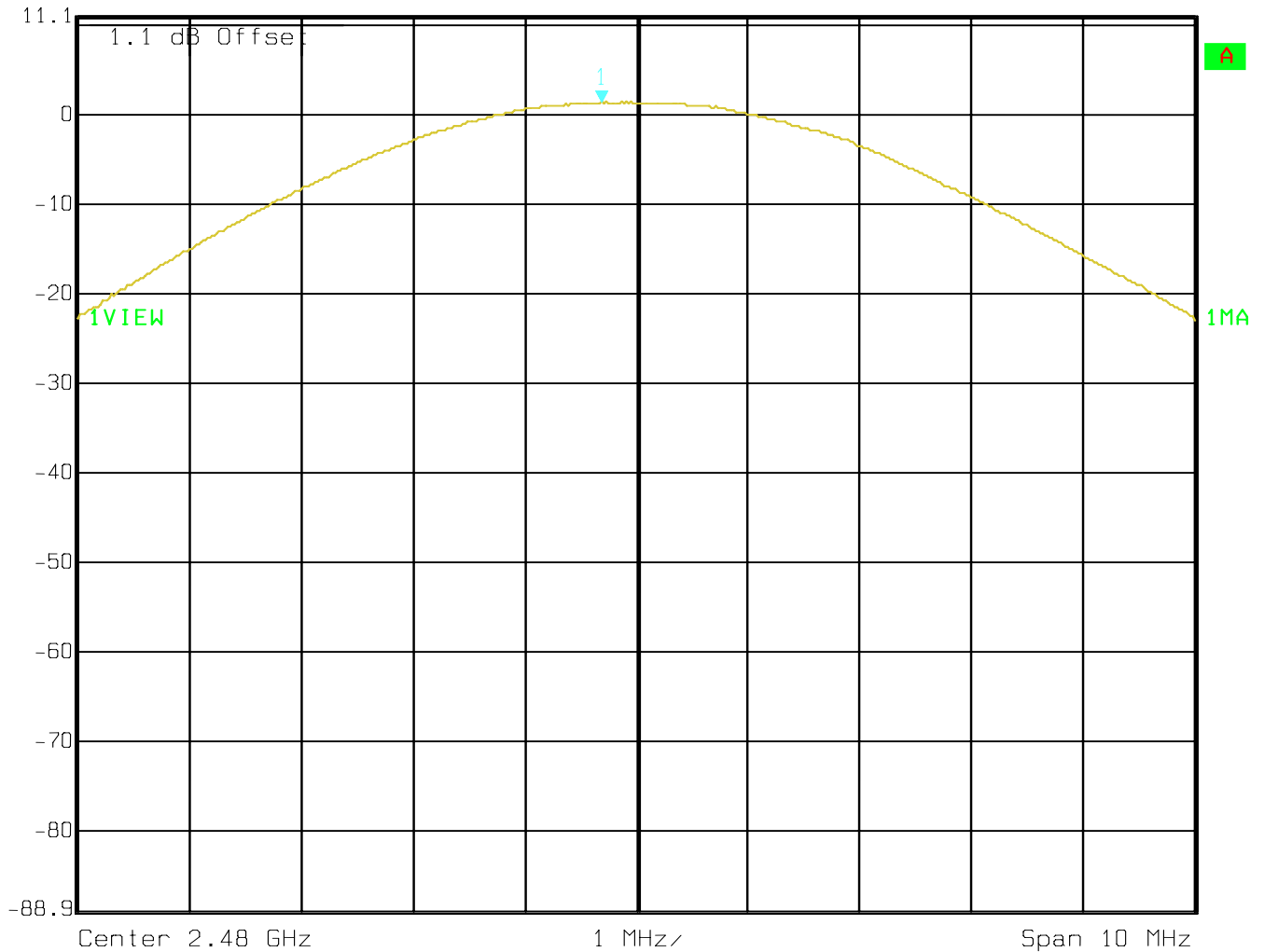

Date: 16.MAY 2007 17:51:33



PEAK OUTPUT POWER (CONDUCTED)

§15.247 (b)

8PSK Lowest Channel: 2402MHz

	Marker 1 [T1]	RBW	3 MHz	RF Att	40 dB
	Ref Lvl	3.16 dBm	VBW	3 MHz	
	11.1 dBm	2.40188978 GHz	SWT	5 ms	Unit dBm

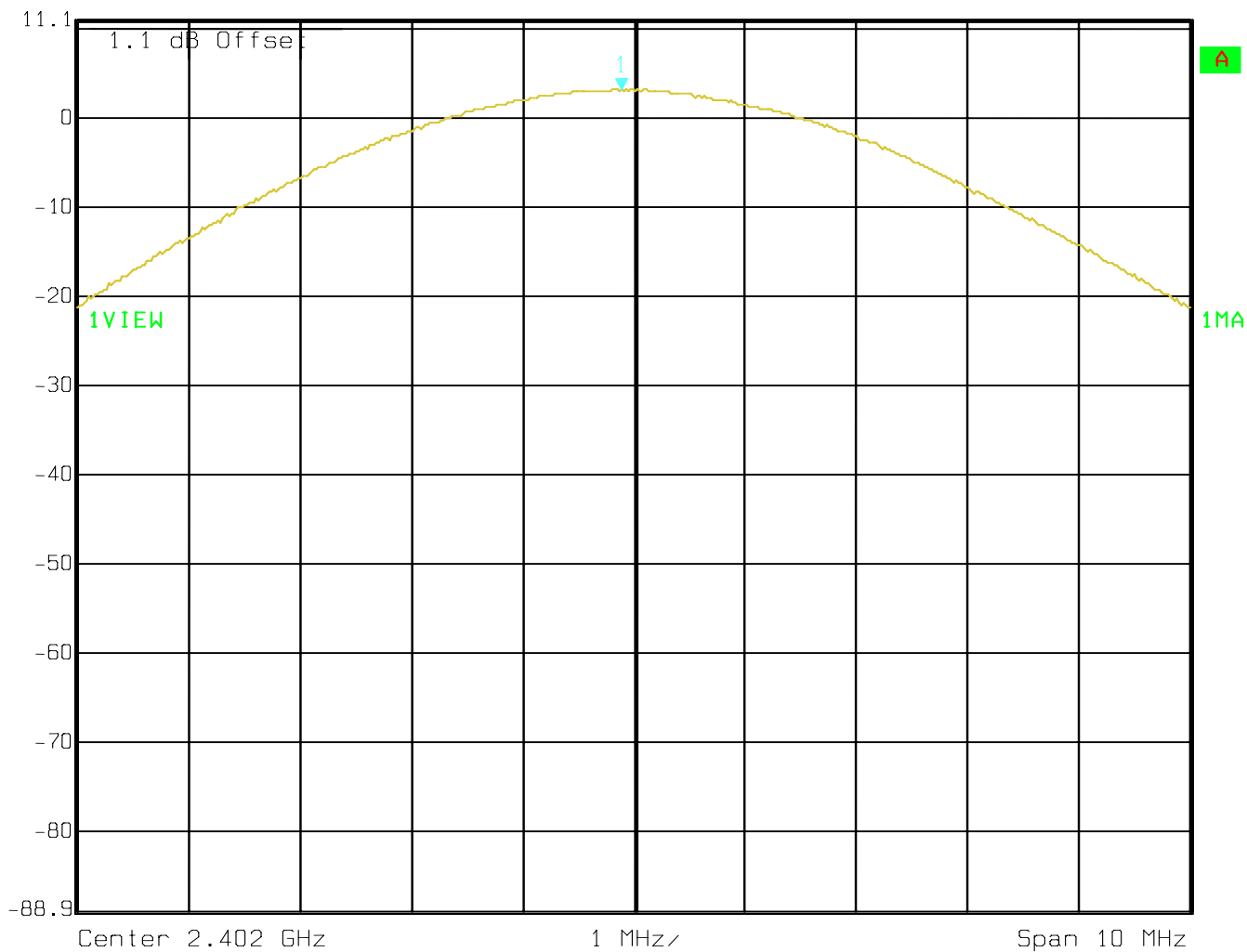

Date: 16.MAY 2007 17:52:57



PEAK OUTPUT POWER (CONDUCTED)

§15.247 (b)

8PSK Mid Channel: 2441MHz



Ref Lvl 11.1 dBm
Marker 1 [T1] 4.36 dBm
2.44080962 GHz
RBW 3 MHz RF Att 40 dB
VBW 3 MHz
SWT 5 ms Unit dBm

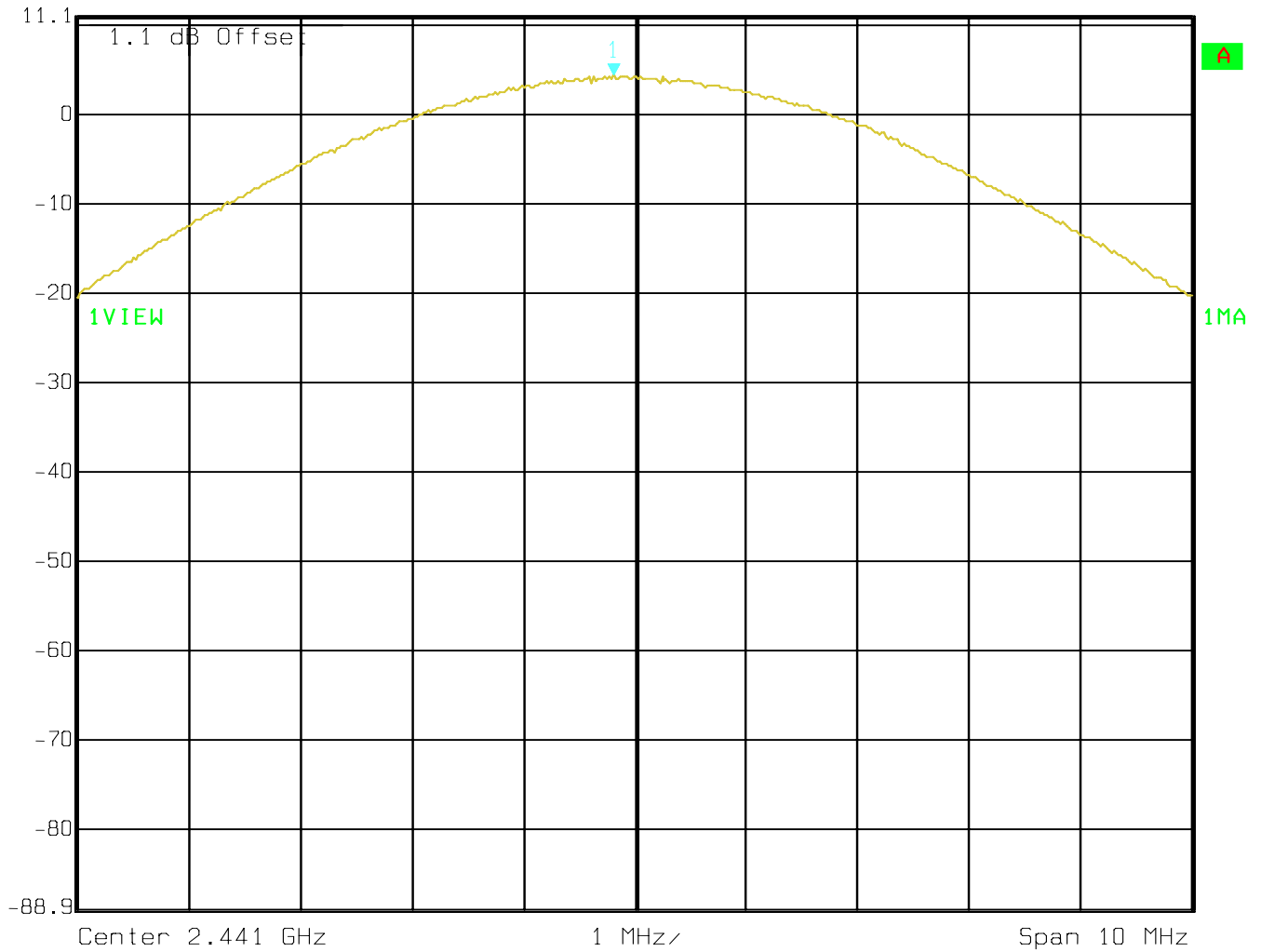

Date: 16.MAY 2007 17:52:32



PEAK OUTPUT POWER (CONDUCTED)

§15.247 (b)

8PSK Highest Channel: 2480MHz



Ref Lvl 11.1 dBm
Marker 1 [T1] 3.71 dBm
2.47968938 GHz
RBW 3 MHz RF Att 40 dB
VBW 3 MHz
SWT 5 ms Unit dBm

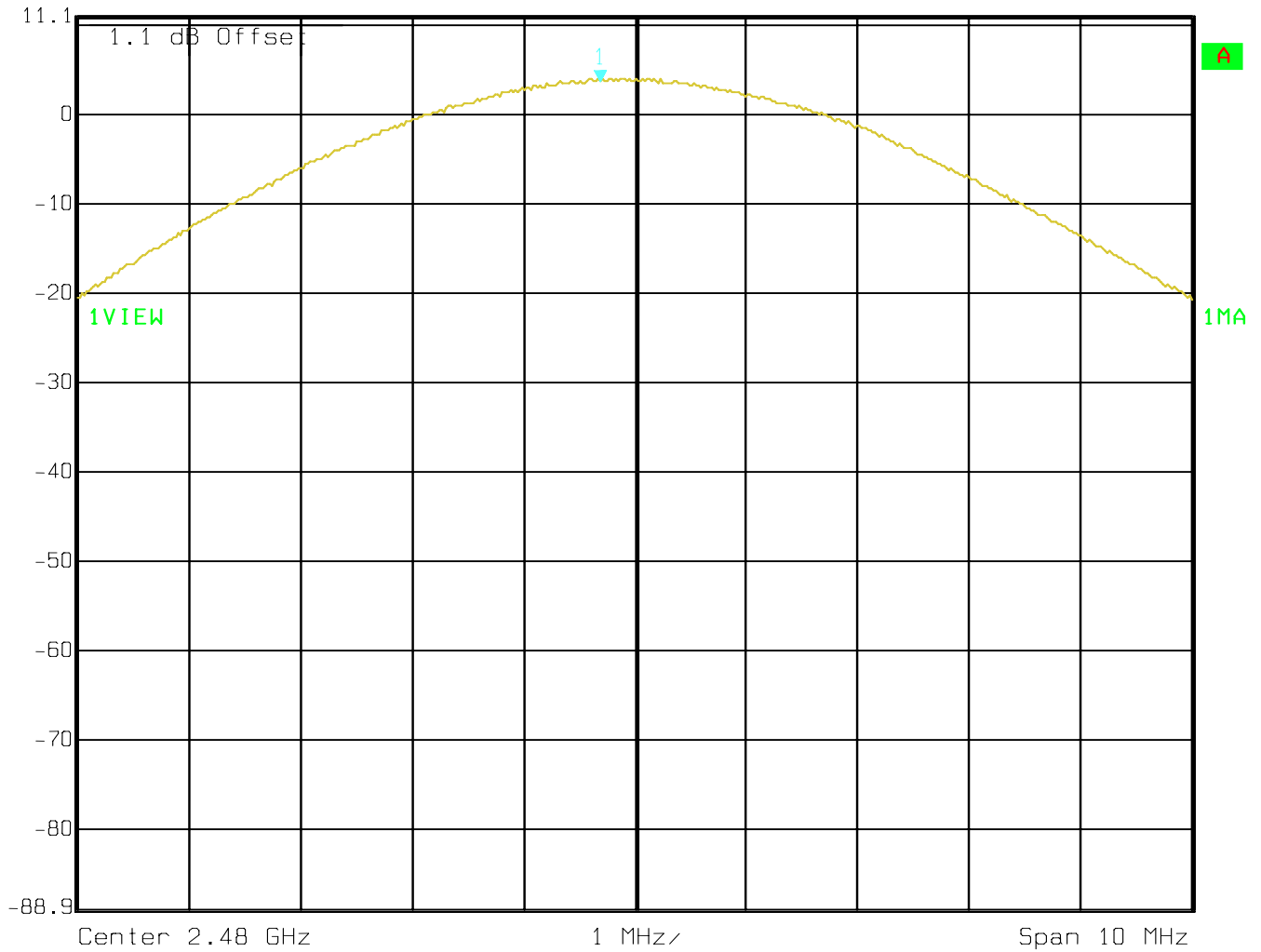

Date: 16.MAY 2007 17:52:05



4.2 20dB BANDWIDTH

4.2.1 LIMIT SUB CLAUSE § 15.247 (a) (1) (i) (ii) (iii)

Alternatively, frequency hopping systems operating in the 2400–2483.5 MHz band may have hopping channel carrier frequencies that are separated by 25 kHz or two-thirds of the 20 dB bandwidth of the hopping channel, whichever is greater, provided the systems operate with an output power no greater than 125 mW.

**SPECTRUM BANDWIDTH OF FHSS SYSTEM
20 dB bandwidth**

§15.247(a)

TEST CONDITIONS	20 dB BANDWIDTH (kHz)		
Frequency (MHz)	2402	2440	2480
GFSK	922	922	922
8PSK	1343	1347	1347



SPECTRUM BANDWIDTH OF FHSS SYSTEM

§15.247(a)

20 dB bandwidth

GFSK Lowest Channel: 2402MHz

	Delta 1 [T1]	RBW	10 kHz	RF Att	30 dB
	Ref Lvl	0.01 dB	VBW	10 kHz	
	1.1 dBm	921.84368737 kHz	SWT	50 ms	Unit dBm

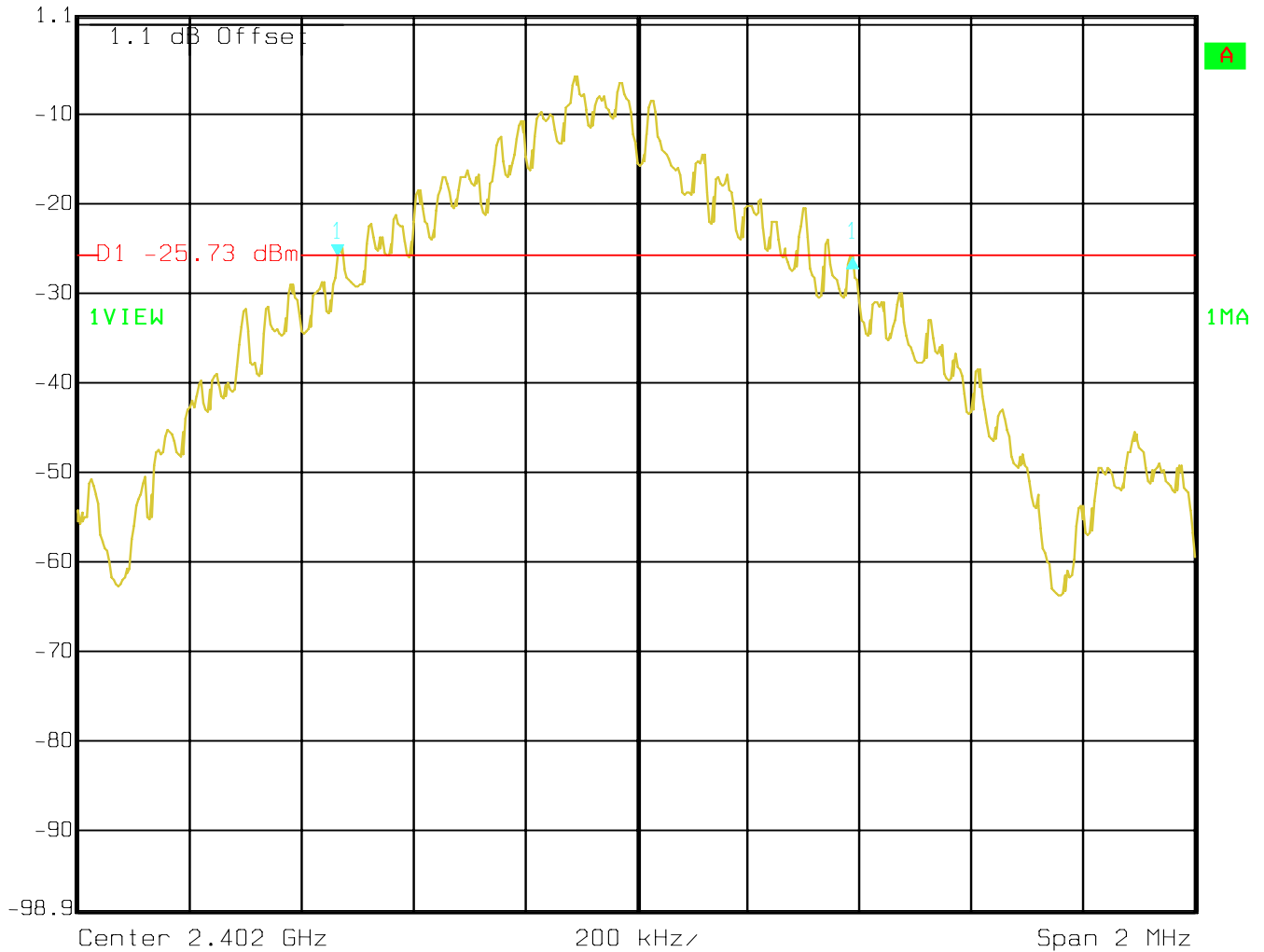

Date: 16.MAY 2007 17:56:45



SPECTRUM BANDWIDTH OF FHSS SYSTEM §15.247(a)

20 dB bandwidth

GFSK Mid Channel: 2441MHz

	Delta 1 [T1]	RBW	10 kHz	RF Att	30 dB
	Ref Lvl	0.36 dB	VBW	10 kHz	
	1.1 dBm	921.84368737 kHz	SWT	50 ms	Unit dBm

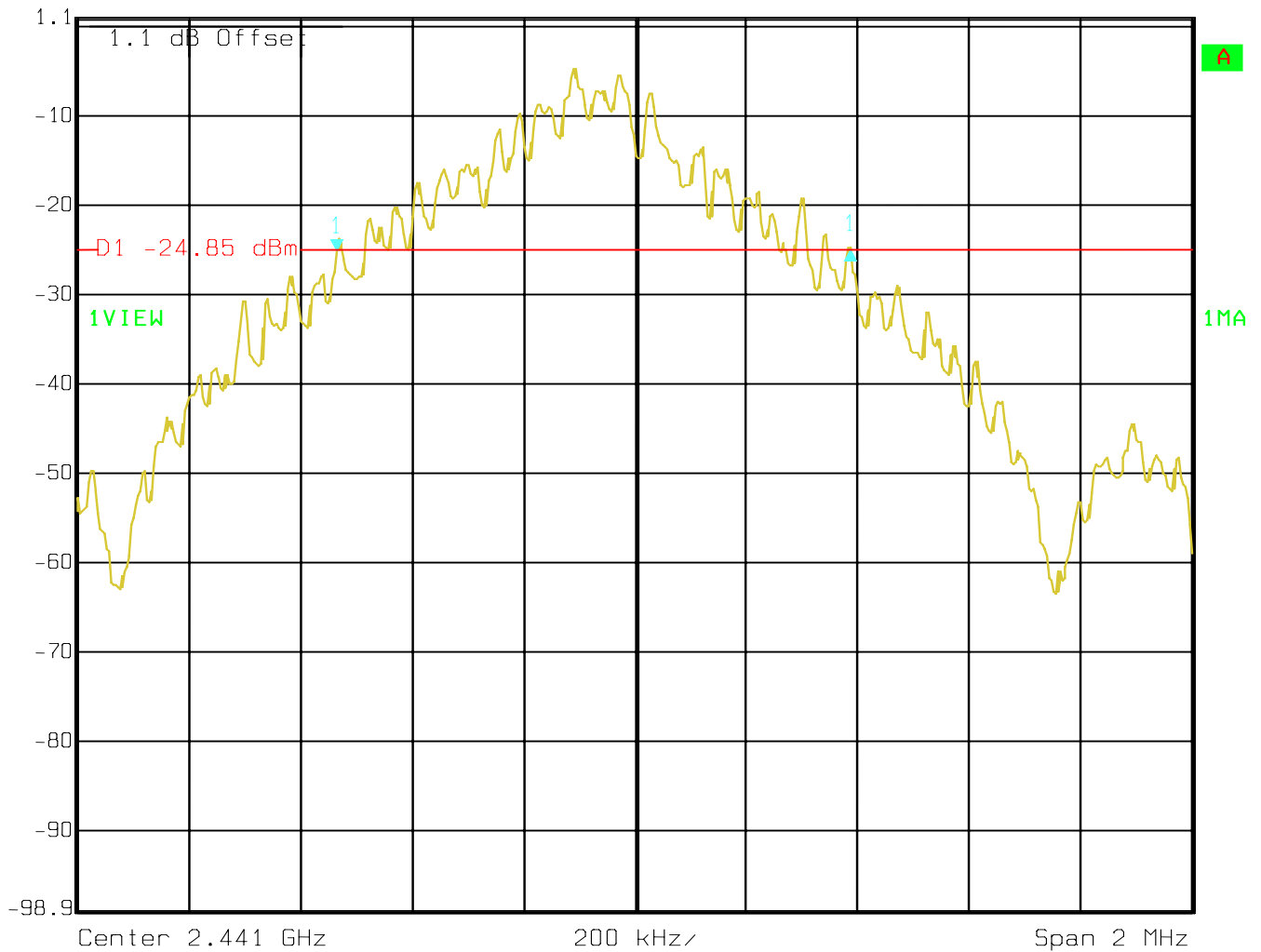

Date: 16.MAY 2007 17:57:30



SPECTRUM BANDWIDTH OF FHSS SYSTEM

§15.247(a)

20 dB bandwidth

GFSK Highest Channel: 2480MHz

	Delta 1 [T1]	RBW	10 kHz	RF Att	30 dB
	Ref Lvl	0.77 dB	VBW	10 kHz	
	1.1 dBm	921.84368738 kHz	SWT	50 ms	Unit dBm

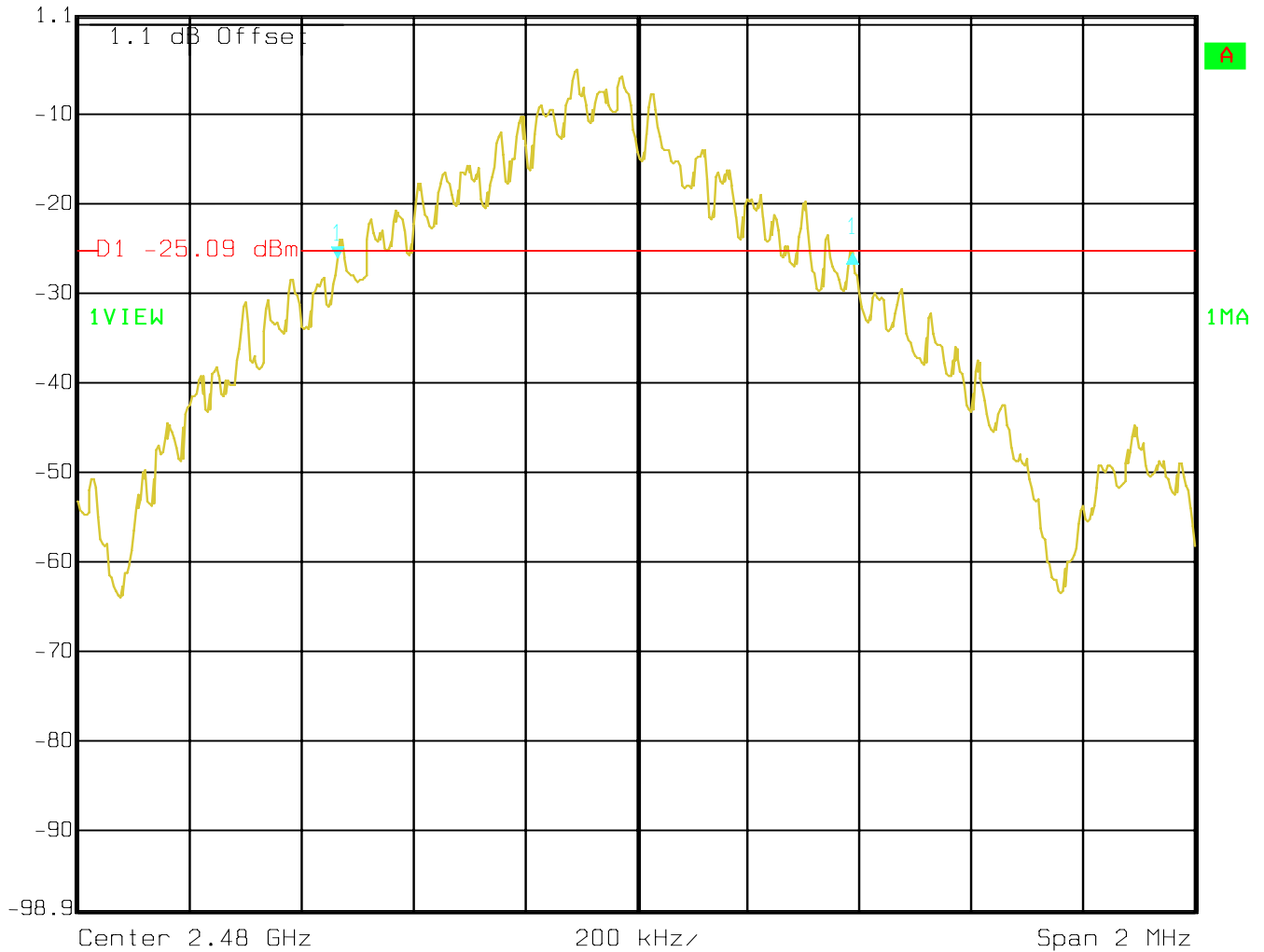

Date: 16.MAY 2007 17:59:46



SPECTRUM BANDWIDTH OF FHSS SYSTEM

§15.247(a)

20 dB bandwidth

8PSK Lowest Channel: 2402MHz

	Delta 1 [T1]	RBW	10 kHz	RF Att	30 dB
Ref Lvl	0.33 dB	VBW	10 kHz	Unit	dBm
1.1 dBm	1.34268537 MHz	SWT	50 ms		

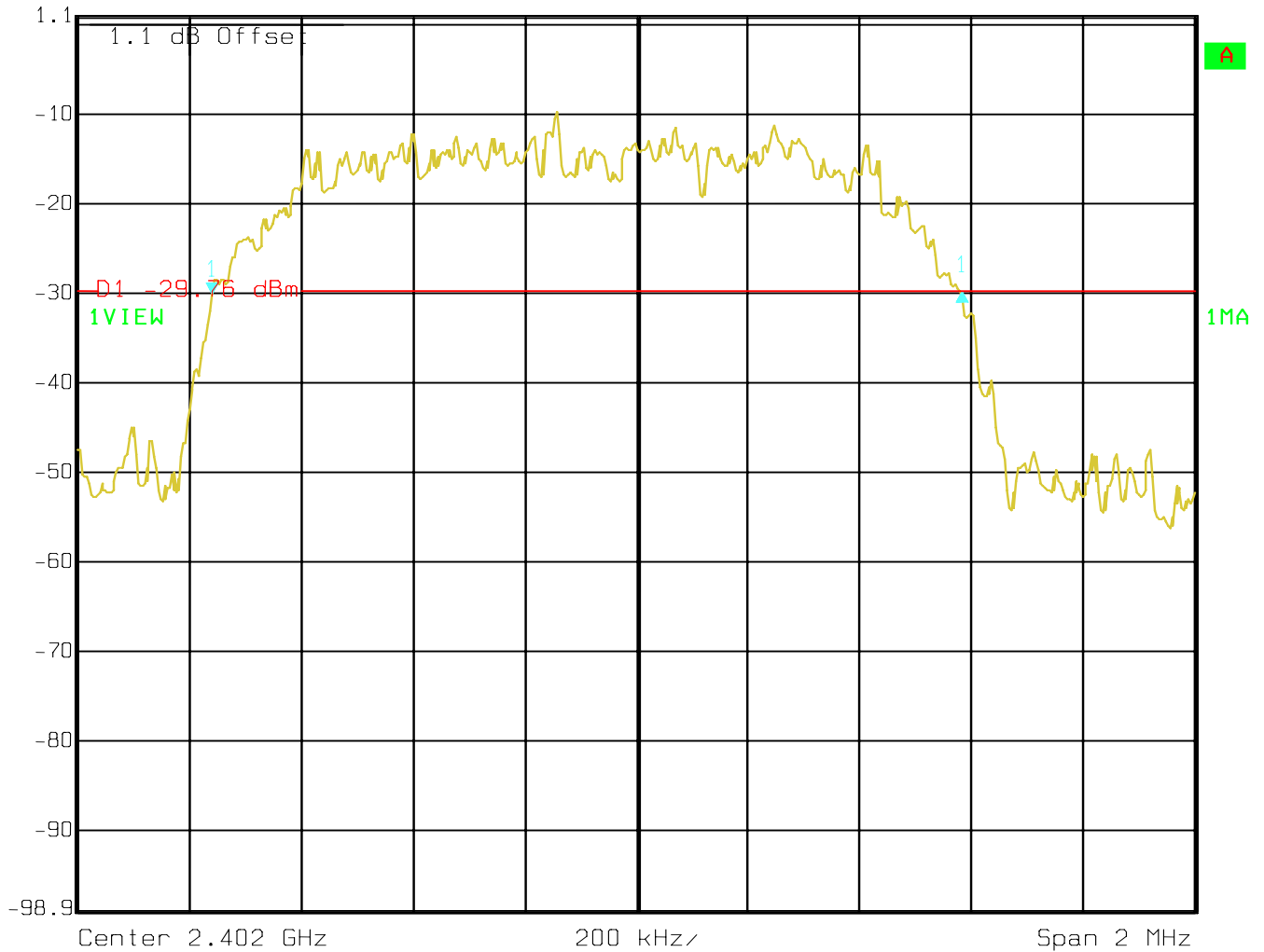

Date: 16.MAY 2007 17:54:51



SPECTRUM BANDWIDTH OF FHSS SYSTEM §15.247(a)

20 dB bandwidth

8PSK Mid Channel: 2441MHz

	Delta 1 [T1]	RBW	10 kHz	RF Att	30 dB
	Ref Lvl	-0.16 dB	VBW	10 kHz	
	1.1 dBm	1.34669339 MHz	SWT	50 ms	Unit dBm

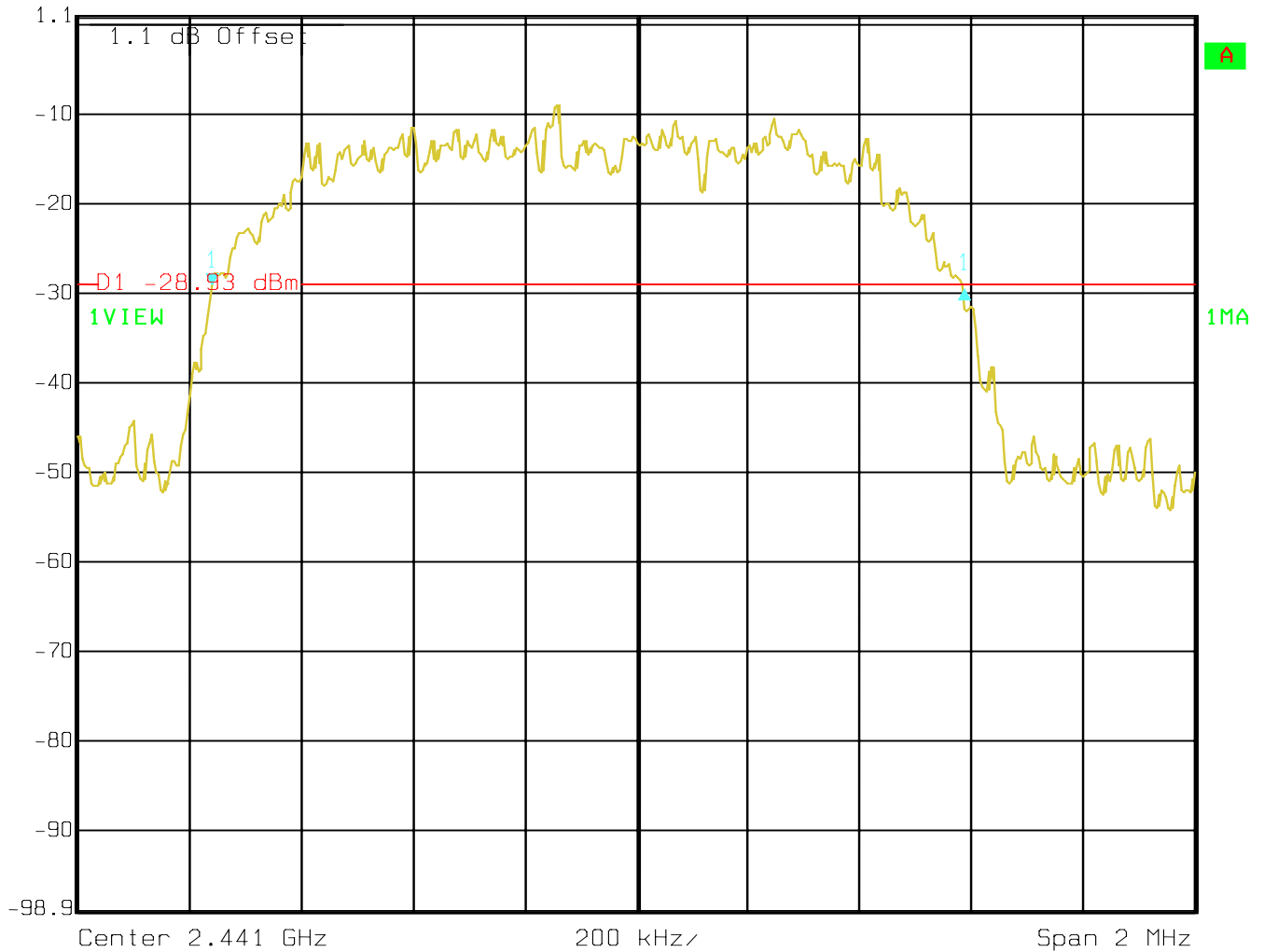

Date: 16.MAY 2007 17:58:11



SPECTRUM BANDWIDTH OF FHSS SYSTEM

§15.247(a)

20 dB bandwidth

8PSK Highest Channel: 2480MHz

	Delta 1 [T1]	RBW	10 kHz	RF Att	30 dB
	Ref Lvl	-0.03 dB	VBW	10 kHz	
	1.1 dBm	1.34669339 MHz	SWT	50 ms	Unit dBm

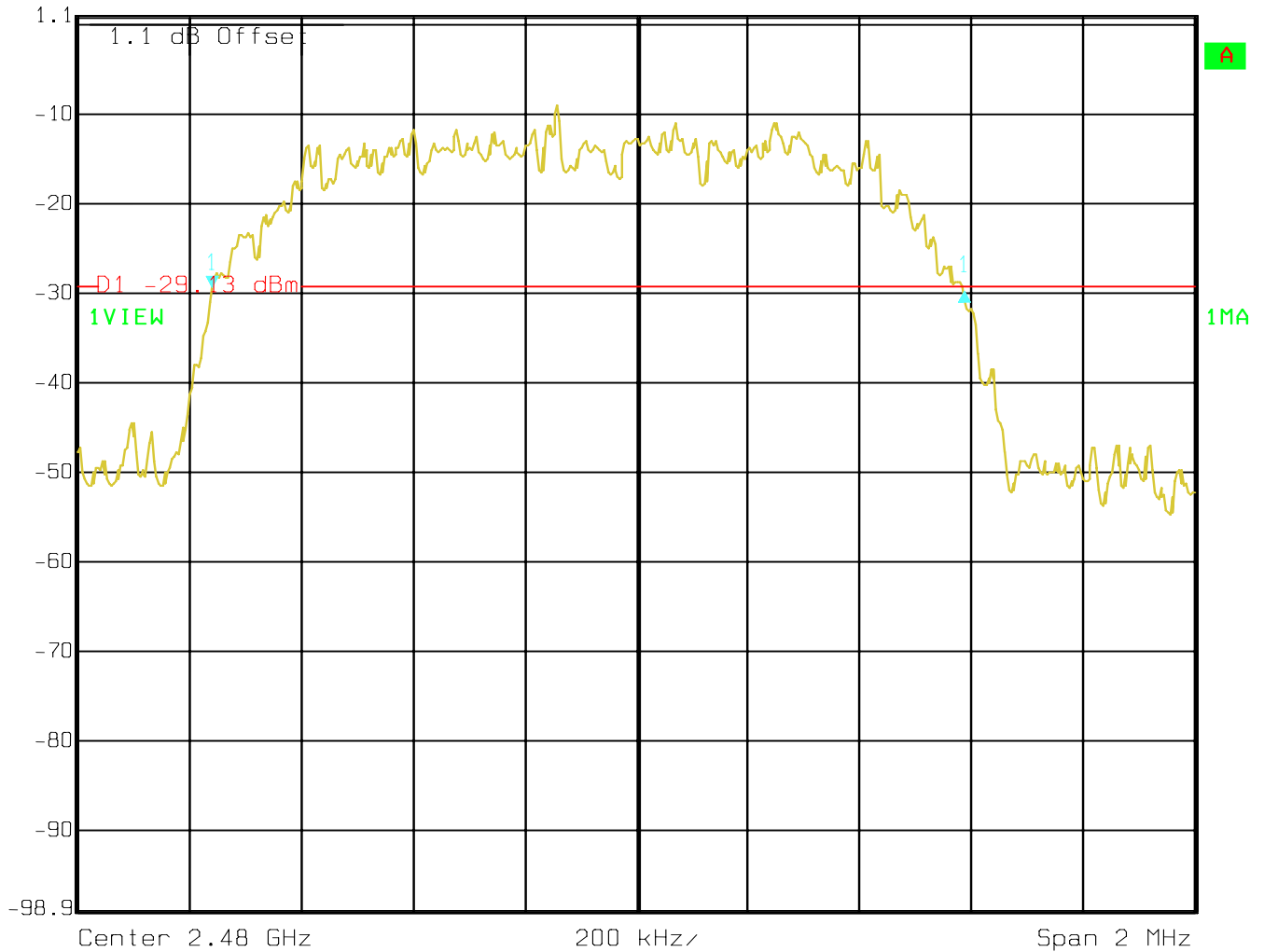

Date: 16.MAY 2007 17:59:07



4.3 CARRIER FREQUENCY SEPARATION

4.3.1 LIMIT SUB CLAUSE § 15.247 (a) (1) (i) (ii) (iii)

SEPARATION
> 25 KHz or > 20 dB BANDWIDTH

4.3.2 RESULTS:

ResultsSEPARATION (MHz)
1.003



4.4 CARRIER FREQUENCY SEPERATION

§15.247(a)



Delta 1 [T1] RBW 100 kHz RF Att 40 dB
Ref Lvl 0.05 dB VBW 1 MHz
11.1 dBm 1.00300601 MHz SWT 5 ms Unit dBm

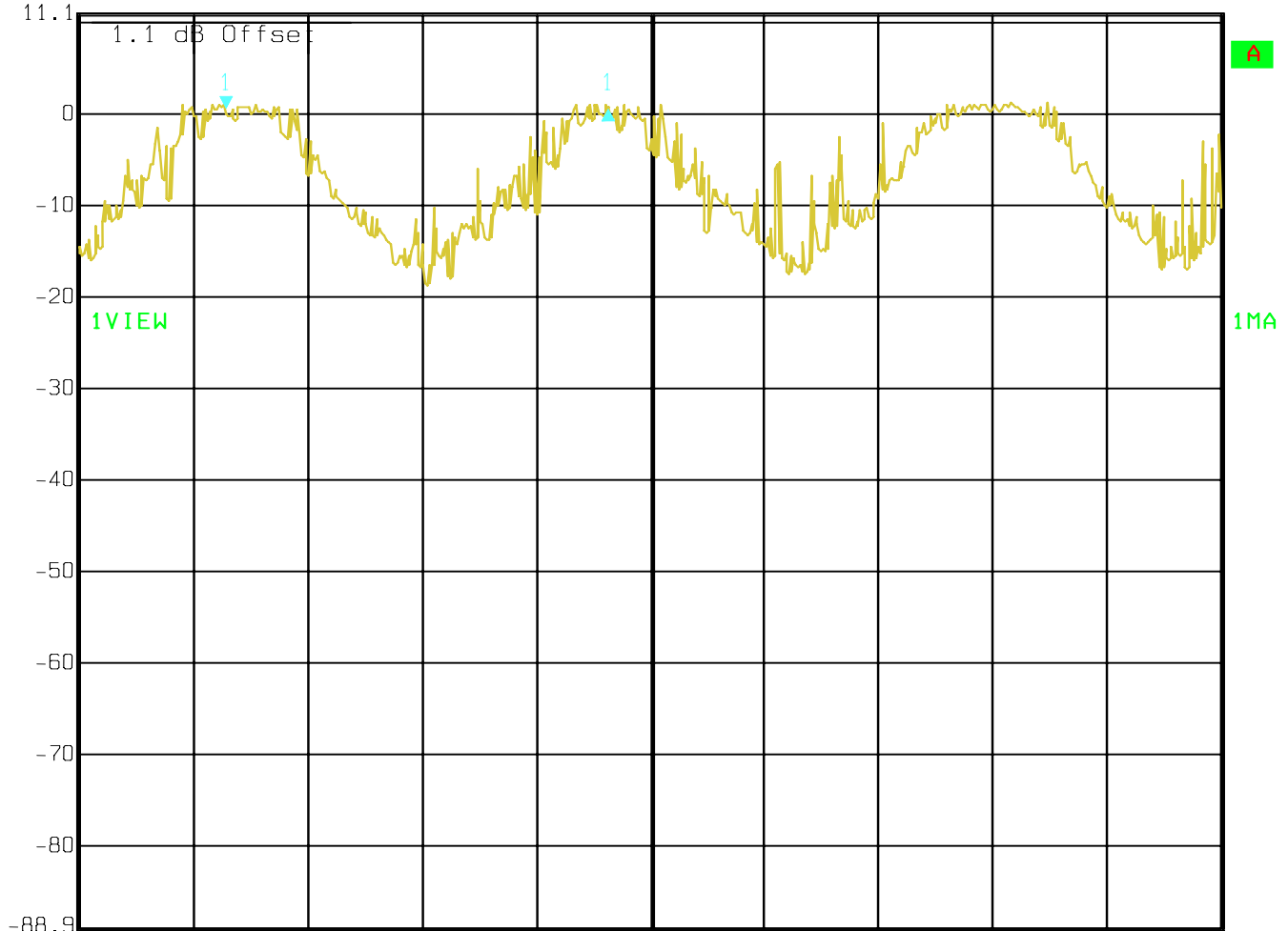

Center 2.441 GHz 300 kHz/ Span 3 MHz

Date: 16.MAY 2007 18:16:11



4.5 NUMBER OF HOPPING CHANNELS

4.5.1 LIMIT SUB CLAUSE § 15.247 (a) (1) (iii)

NUMBER OF CHANNELS
> 15

4.5.2 RESULTS:

NUMBER OF CHANNELS
> 79



NUMBER OF HOPPING CHANNELS

§15.247(a)



Ref Lvl
11.1 dBm

RBW 100 kHz RF Att 40 dB
VBW 1 MHz
SWT 21.5 ms Unit dBm

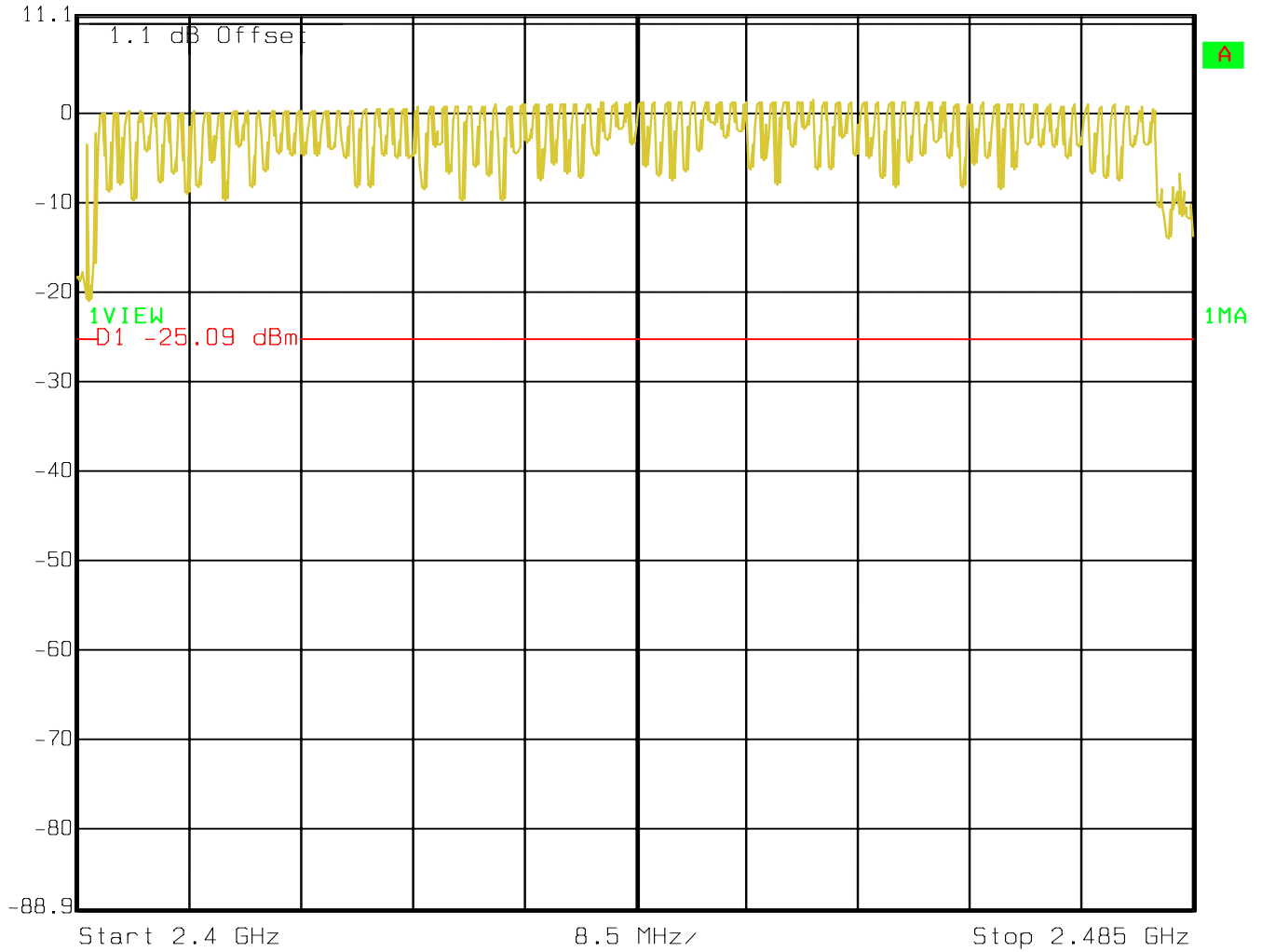

Date: 16.MAY 2007 18:13:43

Test Report #: **BROAD_031_01001_15.247BT**

Date of Report : 2007-05-16

Page 57 of 65



4.6 TIME OF OCCUPANCY (DWELL TIME)

4.6.1 LIMIT SUB CLAUSE § 15.247 (a) (1) (i) (ii) (iii)

FREQUENCY RANGE	AVERAGE TIME OF OCCUPANCY PER 31.6 SECONDS (LIMIT)
2400-2483.5	0.4 SECONDS



TIME OF OCCUPANCY (DWELL TIME)

§15.247(a)

DH5 – Packet

At DH5 Packets you need 5 time slots for transmit and 1 for receiving, then the system makes worst case 266,7 hops per second with 79 channels. So you have each channel 3.36 times per second and so for 30 seconds you have 100.8 times of appearance .

Each tx-time per appearance is xxxx ms.

So we have 100.8 *3.08ms = 310.5 ms per 30 seconds.

RS	Ref Lvl	Delta 1 [T1]	RBW	1 MHz	RF Att	40 dB
	11.1 dBm	-0.03 dB	VBW	1 MHz		
		3.086172 ms	SWT	4 ms	Unit	dBm

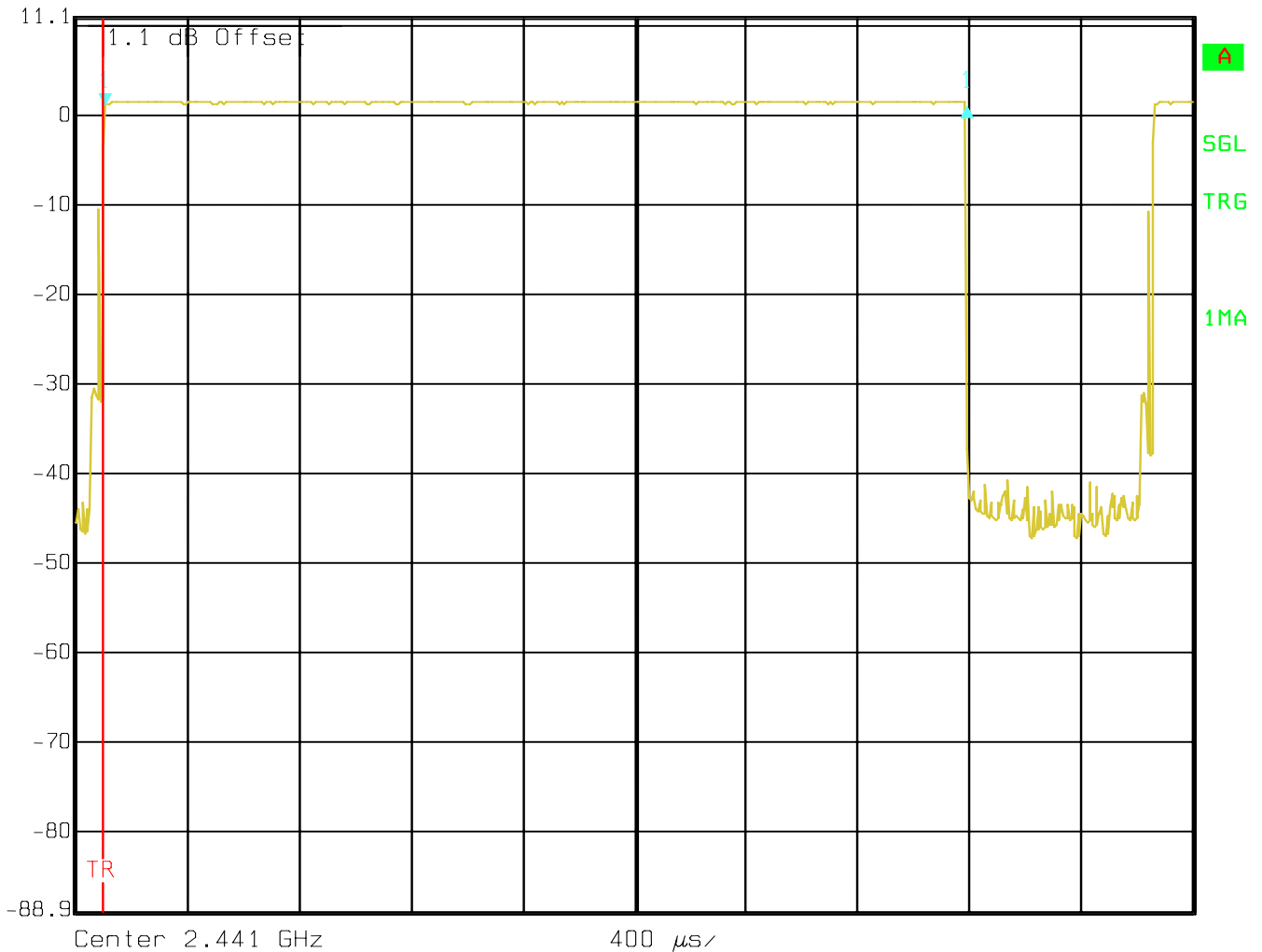

Date: 16.MAY 2007 18:21:09



4.7 CONDUCTED SPURIOUS EMISSION

EMISSION LIMITATIONS

§ 15.247 (c) (1)

Transmitter (Conducted)

LIMITS

In any 100 kHz bandwidth outside the frequency band at least 20dB below the highest level of the desired power. In addition, radiated emissions which fall in the restricted bands, as defined in §15.205(a), must also comply with the radiated emission limits specified in §15.209(a) (see §15.205(c)).

NOTE: Frequency resolution is not fine enough to show the exact frequency of the carrier, refer to plots under EIRP. 8PSK was worst case conducted emissions. Plots show results for 8PSK.



EMISSION LIMITATIONS - Conducted (Transmitter)

§ 15.247 (c) (1)

Lowest Channel(2402MHz): 30MHz - 25GHz

NOTE: The peak above the limit line is the carrier frequency.

	Delta 1 [T1]	RBW	100 kHz	RF Att	40 dB
	Ref Lvl	-39.18 dB	VBW	100 kHz	
	11.1 dBm	2.44438778 GHz	SWT	6.4 s	Unit dBm

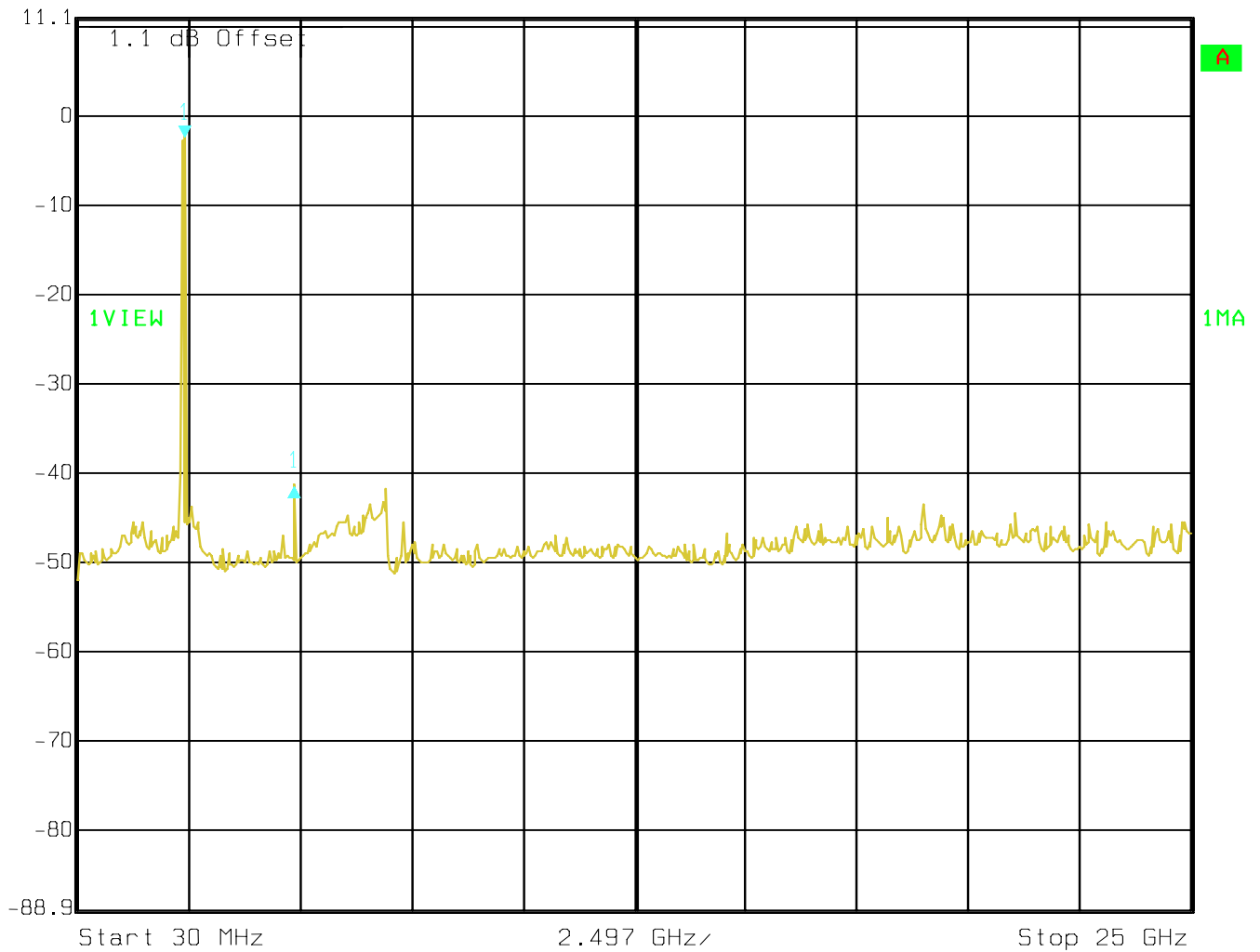

Date: 16.MAY 2007 18:24:21



EMISSION LIMITATIONS - Conducted (Transmitter)

§ 15.247 (c) (1)

Middle Channel(2441MHz): 30MHz - 25GHz

NOTE: The peak above the limit line is the carrier frequency.

	Delta 1 [T1]	RBW	100 kHz	RF Att	40 dB
Ref Lvl	-41.18 dB	VBW	100 kHz		
11.1 dBm	4.49603106 GHz	SWT	6.4 s	Unit	dBm

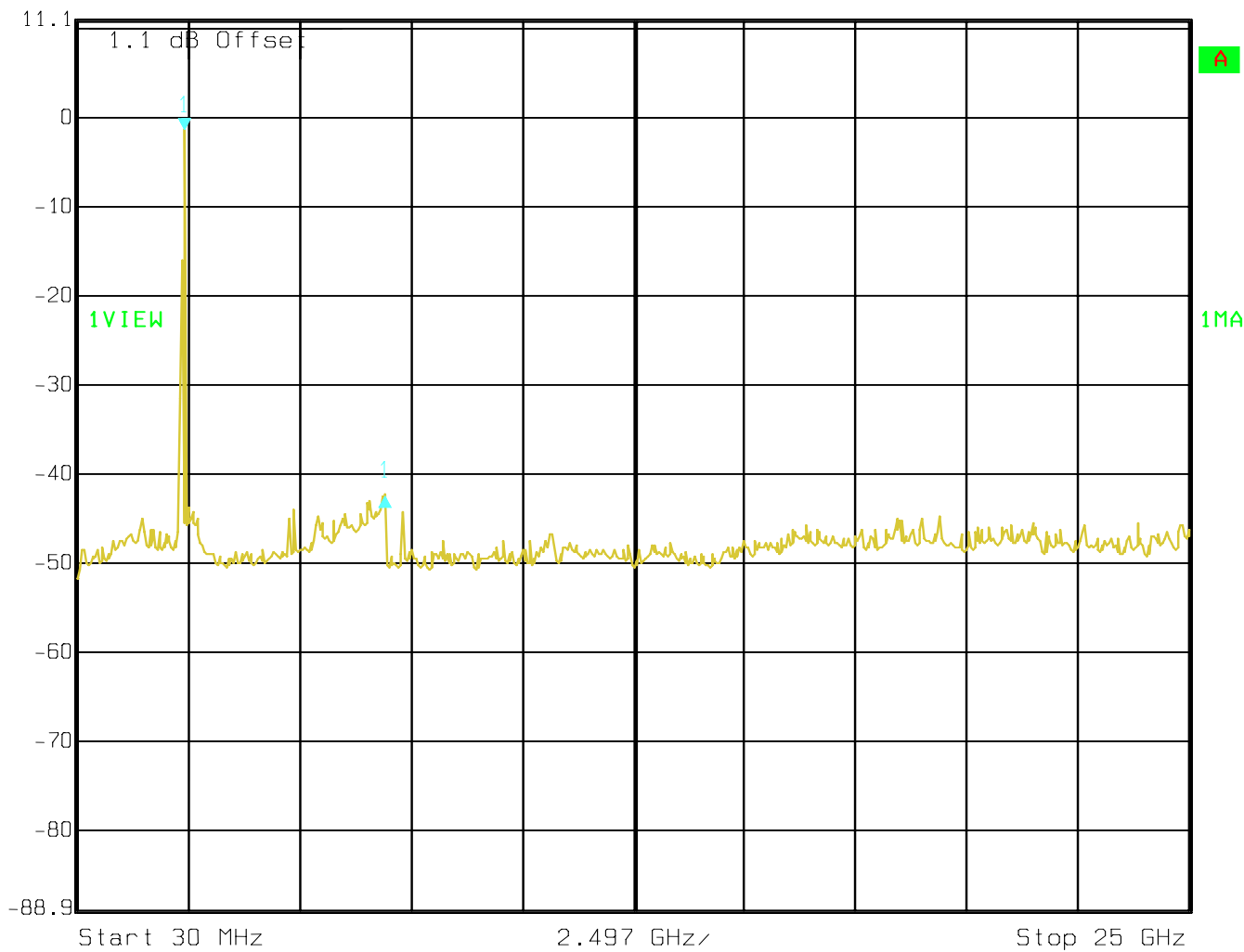

Date: 16.MAY 2007 18:23:47



EMISSION LIMITATIONS - Conducted (Transmitter)

§ 15.247 (c) (1)

Highest Channel(2480MHz): 30MHz - 25GHz

NOTE: The peak above the limit line is the carrier frequency.

	Delta 1 [T1]	RBW	100 kHz	RF Att	40 dB
Ref Lvl	-40.61 dB	VBW	100 kHz		
11.1 dBm	2.44438778 GHz	SWT	6.4 s	Unit	dBm

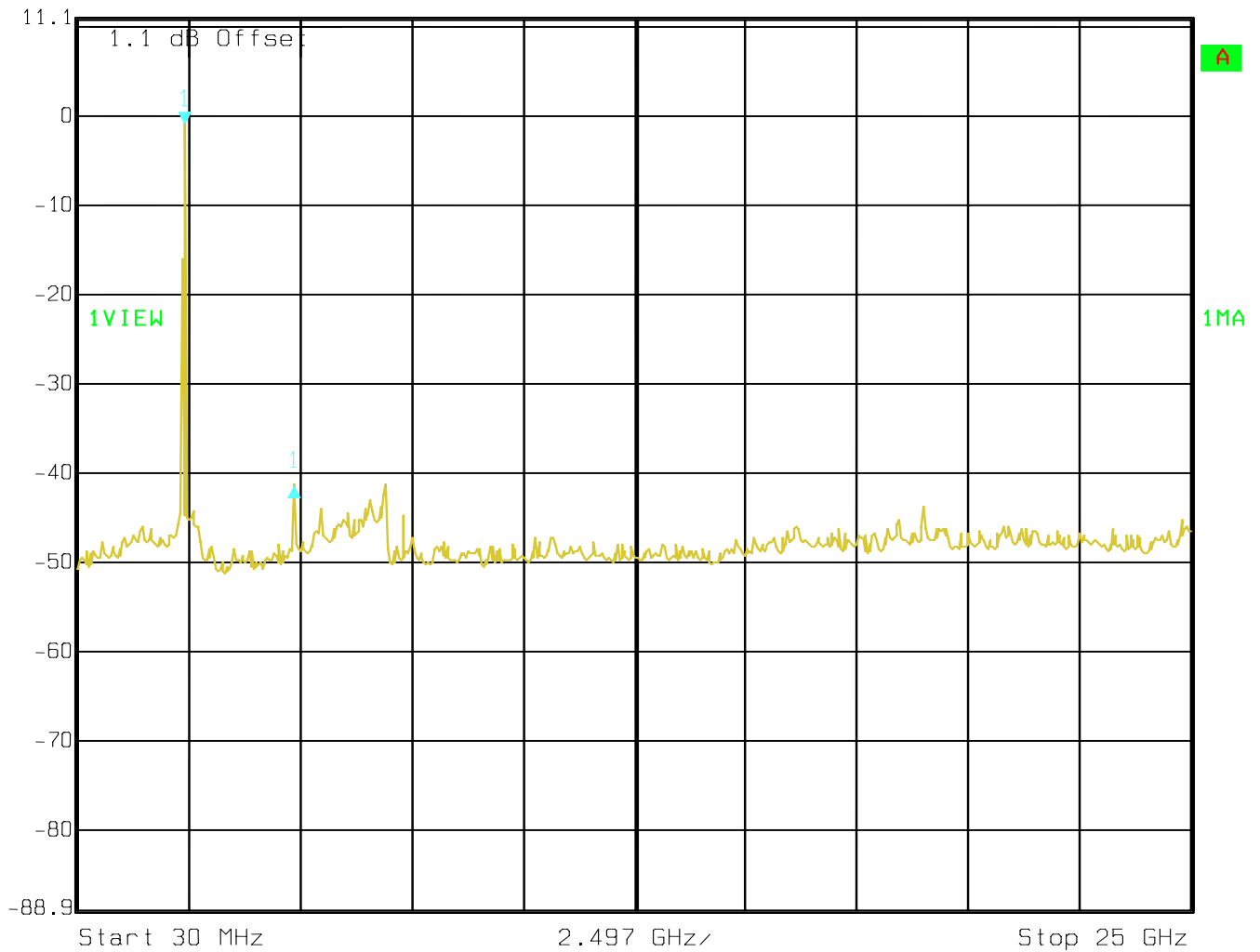

Date: 16.MAY 2007 18:23:12

5 TEST EQUIPMENT AND ANCILLARIES USED FOR TESTS

No	Instrument/Ancillary	Type	Manufacturer	Serial No.	Cal Due	Interval
01	Spectrum Analyzer	ESIB 40	Rohde & Schwarz	100107	May 2007	1 year
02	Spectrum Analyzer	FSEM 30	Rohde & Schwarz	100017	August 2007	1 year
03	Signal Generator	SMY02	Rohde & Schwarz	836878/011	May 2007	1 year
04	Power-Meter	NRVD	Rohde & Schwarz	0857.8008.02	May 2007	1 year
05	Biconilog Antenna	3141	EMCO	0005-1186	June 2007	1 year
06	Horn Antenna (1-18GHz)	SAS-200/571	AH Systems	325	June 2007	1 year
07	Horn Antenna (18-26.5GHz)	3160-09	EMCO	1240	June 2007	1 year
08	Power Splitter	11667B	Hewlett Packard	645348	n/a	n/a
09	Climatic Chamber	VT4004	Voltsch	G1115	May 2007	1 year
10	High Pass Filter	5HC2700	Trilithic Inc.	9926013	n/a	n/a
11	High Pass Filter	4HC1600	Trilithic Inc.	9922307	n/a	n/a
12	Pre-Amplifier	JS4-00102600	Miteq	00616	May 2007	1 year
13	Power Sensor	URV5-Z2	Rohde & Schwarz	DE30807	May 2007	1 year
14	Digital Radio Comm. Tester	CMD-55	Rohde & Schwarz	847958/008	May 2007	1 year
15	Universal Radio Comm. Tester	CMU 200	Rohde & Schwarz	832221/06	May 2007	1 year
16	LISN	ESH3-Z5	Rohde & Schwarz	836679/003	May 2007	1 year
17	Loop Antenna	6512	EMCO	00049838	July 2007	2 years

6 BLOCK DIAGRAMS

Conducted Testing

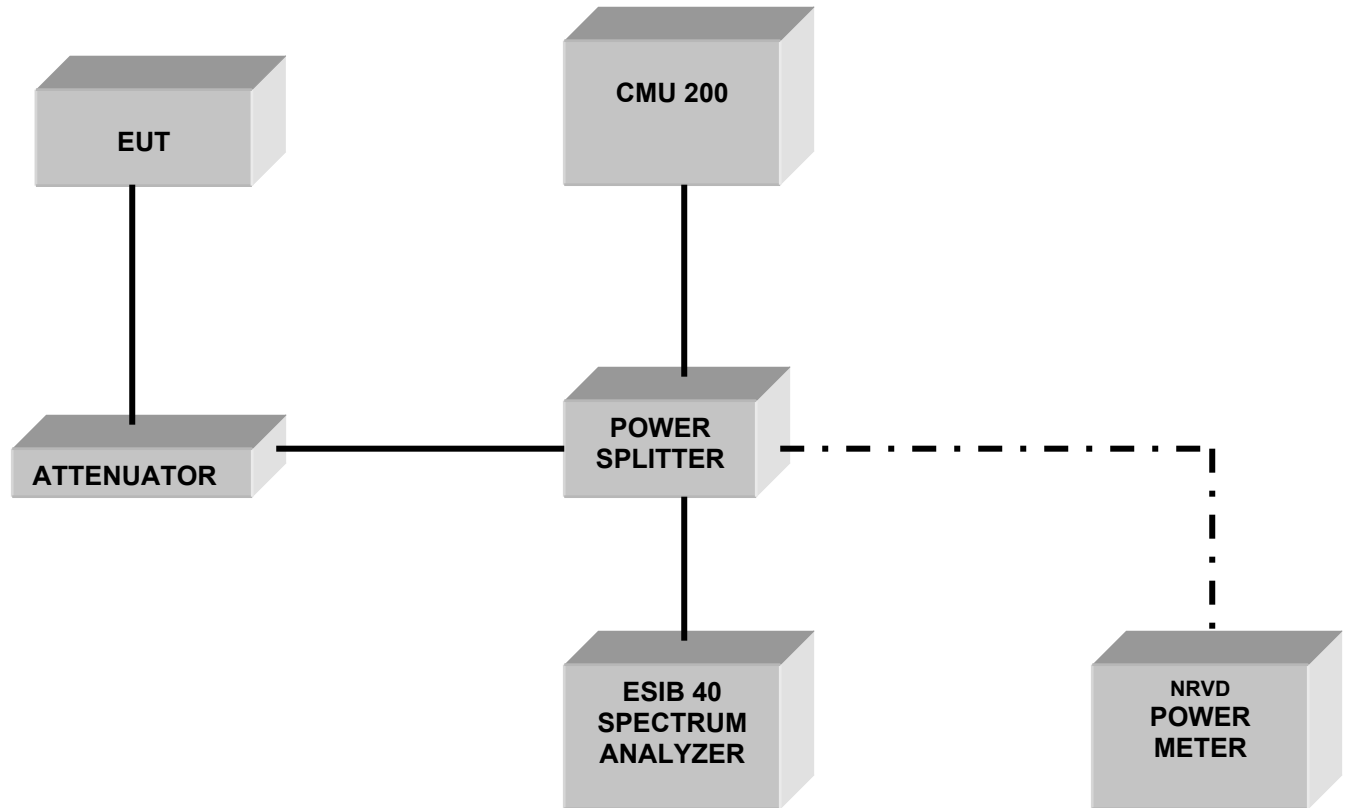

Radiated Testing

ANECHOIC CHAMBER

