

FCC Test Report (LoRa)

Report No.: RF170605E06A-2

FCC ID: M82-WISE3610

Model: WISE-3610XXXXXXXXXXXXXXXXXX
("x"=0-9, A-Z, a-z, dot, diagonal, hyphen or blank.)

Received Date: June 22, 2017

Test Date: June 30 to July 27, 2017

Issued Date: Sep. 14, 2017

Applicant: ADVANTECH CO., LTD

Address: No.1, Alley 20, Lane 26, Rueiguang Rd, Neihu District, Taipei, Taiwan 114

Issued By: Bureau Veritas Consumer Products Services (H.K.) Ltd., Taoyuan Branch
Hsin Chu Laboratory

Lab Address: E-2, No.1, Li Hsin 1st Road, Hsinchu Science Park, Hsinchu City 300,
Taiwan R.O.C.

Test Location (1): E-2, No.1, Li Hsin 1st Road, Hsinchu Science Park, Hsinchu City 300,
Taiwan R.O.C.

Test Location (2): No. 49, Ln. 206, Wende Rd., Shangshan Tsuen, Chiung Lin Hsiang, Hsin
Chu Hsien 307, Taiwan R.O.C.



This report is for your exclusive use. Any copying or replication of this report to or for any other person or entity, or use of our name or trademark, is permitted only with our prior written permission. This report sets forth our findings solely with respect to the test samples identified herein. The results set forth in this report are not indicative or representative of the quality or characteristics of the lot from which a test sample was taken or any similar or identical product unless specifically and expressly noted. Our report includes all of the tests requested by you and the results thereof based upon the information that you provided to us. You have 60 days from date of issuance of this report to notify us of any material error or omission caused by our negligence, provided, however, that such notice shall be in writing and shall specifically address the issue you wish to raise. A failure to raise such issue within the prescribed time shall constitute your unqualified acceptance of the completeness of this report, the tests conducted and the correctness of the report contents. Unless specific mention, the uncertainty of measurement has been explicitly taken into account to declare the compliance or non-compliance to the specification. The report must not be used by the client to claim product certification, approval, or endorsement by TAF or any government agencies.

Table of Contents

Release Control Record	4
1 Certificate of Conformity	5
2 Summary of Test Results	6
2.1 Measurement Uncertainty	6
2.2 Modification Record	6
3 General Information	7
3.1 General Description of EUT (LoRa)	7
3.2 Description of Test Modes	9
3.2.1 Test Mode Applicability and Tested Channel Detail	10
3.3 Duty Cycle of Test Signal	12
3.4 Description of Support Units	13
3.4.1 Configuration of System under Test	14
3.5 General Description of Applied Standards	15
4 Test Types and Results	16
4.1 Radiated Emission and Bandedge Measurement	16
4.1.1 Limits of Radiated Emission and Bandedge Measurement	16
4.1.2 Test Instruments	17
4.1.3 Test Procedures	19
4.1.4 Deviation from Test Standard	19
4.1.5 Test Setup	20
4.1.6 EUT Operating Conditions	21
4.1.7 Test Results	22
4.2 Conducted Emission Measurement	28
4.2.1 Limits of Conducted Emission Measurement	28
4.2.2 Test Instruments	28
4.2.3 Test Procedures	29
4.2.4 Deviation from Test Standard	29
4.2.5 Test Setup	29
4.2.6 EUT Operating Conditions	29
4.2.7 Test Results	30
4.3 6dB Bandwidth Measurement	32
4.3.1 Limits of 6dB Bandwidth Measurement	32
4.3.2 Test Setup	32
4.3.3 Test Instruments	32
4.3.4 Test Procedure	32
4.3.5 Deviation from Test Standard	32
4.3.6 EUT Operating Conditions	32
4.3.7 Test Result	33
4.4 Conducted Output Power Measurement	34
4.4.1 Limits of Conducted Output Power Measurement	34
4.4.2 Test Setup	34
4.4.3 Test Instruments	34
4.4.4 Test Procedures	34
4.4.5 Deviation from Test Standard	34
4.4.6 EUT Operating Conditions	34
4.4.7 Test Results	35
4.5 Power Spectral Density Measurement	36
4.5.1 Limits of Power Spectral Density Measurement	36
4.5.2 Test Setup	36
4.5.3 Test Instruments	36
4.5.4 Test Procedure	36
4.5.5 Deviation from Test Standard	36
4.5.6 EUT Operating Condition	36

4.5.7 Test Results	37
4.6 Conducted Out of Band Emission Measurement	38
4.6.1 Limits of Conducted Out of Band Emission Measurement.....	38
4.6.2 Test Setup.....	38
4.6.3 Test Instruments	38
4.6.4 Test Procedure	38
4.6.5 Deviation from Test Standard	38
4.6.6 EUT Operating Condition	38
4.6.7 Test Results	39
5 Pictures of Test Arrangements.....	40
Appendix – Information on the Testing Laboratories	41

Release Control Record

Issue No.	Description	Date Issued
RF170605E06A-2	Original release.	Sep. 14, 2017

1 Certificate of Conformity

Product: IoT Gateway

Brand: ADVANTECH

Model: WISE-3610XXXXXXXXXXXXXXXXXX
("x"=0-9, A-Z, a-z, dot, diagonal, hyphen or blank.)

Sample Status: ENGINEERING SAMPLE

Applicant: ADVANTECH CO., LTD

Test Date: June 30 to July 27, 2017

Standards: 47 CFR FCC Part 15, Subpart C (Section 15.247)
ANSI C63.10: 2013

The above equipment has been tested by **Bureau Veritas Consumer Products Services (H.K.) Ltd., Taoyuan Branch**, and found compliance with the requirement of the above standards. The test record, data evaluation & Equipment Under Test (EUT) configurations represented herein are true and accurate accounts of the measurements of the sample's EMC characteristics under the conditions specified in this report.

Prepared by :  , **Date:** Sep. 14, 2017
Claire Kuan / Specialist

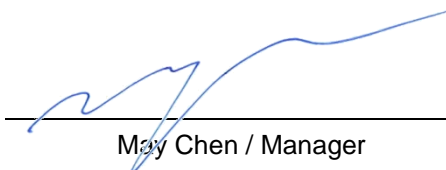
Approved by :  , **Date:** Sep. 14, 2017
May Chen / Manager

2 Summary of Test Results

47 CFR FCC Part 15, Subpart C (SECTION 15.247)			
FCC Clause	Test Item	Result	Remarks
15.207	AC Power Conducted Emission	PASS	Meet the requirement of limit. Minimum passing margin is -14.00dB at 0.44297MHz.
15.205 & 209 & 15.247(d)	Radiated Emissions & Band Edge Measurement	PASS	Meet the requirement of limit. Minimum passing margin is -3.1dB at 672.00MHz.
15.247(d)	Antenna Port Emission	PASS	Meet the requirement of limit.
15.247(a)(2)	6dB bandwidth	PASS	Meet the requirement of limit.
15.247(b)	Conducted power	PASS	Meet the requirement of limit.
15.247(e)	Power Spectral Density	PASS	Meet the requirement of limit.
15.203	Antenna Requirement	PASS	Antenna connector is Reverse SMA not a standard connector.

2.1 Measurement Uncertainty

Where relevant, the following measurement uncertainty levels have been estimated for tests performed on the EUT as specified in CISPR 16-4-2:

Measurement	Frequency	Expanded Uncertainty (k=2) (\pm)
Conducted Emissions at mains ports	150kHz ~ 30MHz	1.84 dB
Radiated Emissions up to 1 GHz	30MHz ~ 1GHz	5.30 dB
	1GHz ~ 6GHz	5.16 dB
Radiated Emissions above 1 GHz	6GHz ~ 18GHz	4.91 dB
	18GHz ~ 40GHz	5.30 dB

2.2 Modification Record

There were no modifications required for compliance.

3 General Information

3.1 General Description of EUT (LoRa)

Product	IoT Gateway
Brand	ADVANTECH
Model	WISE-3610XXXXXXXXXXXXXXXXXX ("x"=0-9, A-Z, a-z, dot, diagonal, hyphen or blank.)
Status of EUT	ENGINEERING SAMPLE
Power Supply Rating	DC 12V from adapter
Modulation Type	CSS
Operating Frequency	923.3MHz ~ 927.5MHz
Number of Channel	8
Output Power	95.94 mW
Antenna Type	Refer to Note
Antenna Connector	Refer to Note
Accessory Device	Adapter x 1
Data Cable Supplied	NA

Note:

1. The EUT has below type, which are identical to each other in all aspects except for the following:

Brand	Model	Type	Difference
ADVANTECH	WISE-3610XXXXXXXXXXXXXXXXXX ("x"=0-9, A-Z, a-z, dot, diagonal, hyphen or blank.)	1	With 3G card : 1x WAN, 1x LAN, 1x RS232/422/485, LoRa (Module) + 3G (Telit HE-910D Module, 1x2, Rx diversity, certificated already) + Wi-Fi 2x2 IEEE 802.11a/b/g/n/ac(On board design)
		2	Without 3G card : 1x WAN, 1x LAN, 1x RS232/422/485, LoRa (Module) + Wi-Fi 2x2 IEEE 802.11a/b/g/n/ac (On board design)

Note:

- Type 1 was chosen for final test.
- From the above models, model: WISE-3610XXXXXXXXXXXXXXXXXX was selected as representative model for the test and its data was recorded in this report.

2. The EUT is a WLAN, WWAN, LTE and LoRa device.

3. Simultaneously transmission condition.

Condition	Technology			
1	WLAN 2.4GHz	WLAN 5GHz	WWAN (3G)	LoRa

Note: The emission of the simultaneous operation has been evaluated and no non-compliance was found.

4. The EUT must be supplied with a adapter as following table:

Brand	Model No.	Spec.
FSP	FSP036-RBBN2	AC Input: 100-240V, 1.2A, 50-60Hz DC Output: 12V, 3.0A DC Out put cable: Unshielded, 1.5m with one core

5. The antennas provided to the EUT, please refer to the following table:

For LoRa								
Antenna No	Brand	Model	Antenna Gain(dBi) without cable loss	Frequency	Antenna Type	Antenna Connector	Cable Loss(dB)	Cable Length (mm)
1	Cortec	AN0915-9207BSM	0.96	902~928 MHz	Dipole	Reverse SMA	0.5	160
2	Cortec	AN0915-9207BSM	0.96	902~928 MHz	Dipole	Reverse SMA	0.5	160
For WLAN								
Antenna No	Brand	Model	Antenna Gain(dBi) without cable loss	Frequency	Antenna Type	Antenna Connector	Cable Loss(dB)	Cable Length (mm)
3	Cortec	AN2450-92K01BRS	5.03	2400~2483.5 MHz	Dipole	Reverse SMA	0.5	180
			5.01	5150~5850 MHz	Dipole	Reverse SMA	0.8	180
For WWAN								
Antenna No	Brand	Model	Gain (dBi) <excluding cable loss>	Frequency	Antenna Type	Antenna Connector		
4	SINBON.	1750008424-01	-0.5	824~896 MHz	Dipole	SMA		
			-0.2	880~960 MHz				
			1.5	1427~1880 MHz				
			1.95	1850~1990 MHz				

6. The above EUT information is declared by manufacturer and for more detailed features description, please refer to the manufacturer's specifications or user's manual.

3.2 Description of Test Modes

8 channels are provided to this EUT:

Channel	Freq. (MHz)	Channel	Freq. (MHz)
0	923.3	4	925.7
1	923.9	5	926.3
2	924.5	6	926.9
3	925.1	7	927.5

3.2.1 Test Mode Applicability and Tested Channel Detail

EUT CONFIGURE MODE	APPLICABLE TO				DESCRIPTION
	RE \geq 1G	RE<1G	PLC	APCM	
-	√	√	√	√	-

Where **RE \geq 1G**: Radiated Emission above 1GHz

RE<1G: Radiated Emission below 1GHz

PLC: Power Line Conducted Emission

APCM: Antenna Port Conducted Measurement

NOTE: The EUT had been pre-tested on the positioned of each 3 axis. The worst case was found when positioned on **X-plane**.

Radiated Emission Test (Above 1GHz):

- Pre-Scan has been conducted to determine the worst-case mode from all possible combinations between available modulations, data rates and antenna ports (if EUT with antenna diversity architecture).
- Following channel(s) was (were) selected for the final test as listed below.

AVAILABLE CHANNEL	TESTED CHANNEL	MODULATION TYPE
0 to 7	0, 7	CSS

Radiated Emission Test (Below 1GHz):

- Pre-Scan has been conducted to determine the worst-case mode from all possible combinations between available modulations, data rates and antenna ports (if EUT with antenna diversity architecture).
- Following channel(s) was (were) selected for the final test as listed below.

AVAILABLE CHANNEL	TESTED CHANNEL	MODULATION TYPE
0 to 7	0, 7	CSS

Power Line Conducted Emission Test:

- Pre-Scan has been conducted to determine the worst-case mode from all possible combinations between available modulations, data rates and antenna ports (if EUT with antenna diversity architecture).
- Following channel(s) was (were) selected for the final test as listed below.

AVAILABLE CHANNEL	TESTED CHANNEL	MODULATION TYPE
0 to 7	0, 7	CSS

Antenna Port Conducted Measurement:

- This item includes all test value of each mode, but only includes spectrum plot of worst value of each mode.
- Pre-Scan has been conducted to determine the worst-case mode from all possible combinations between available modulations, data rates and antenna ports (if EUT with antenna diversity architecture).
- Following channel(s) was (were) selected for the final test as listed below.

AVAILABLE CHANNEL	TESTED CHANNEL	MODULATION TYPE
0 to 7	0, 7	CSS

Test Condition:

APPLICABLE TO	ENVIRONMENTAL CONDITIONS	INPUT POWER	TESTED BY
RE \geq 1G	24deg. C, 68%RH	120Vac, 60Hz	Jyunchun Lin
RE<1G	24deg. C, 68%RH	120Vac, 60Hz	Eason Teng
PLC	24deg. C, 75%RH	120Vac, 60Hz	Andy Ho
APCM	25deg. C, 60%RH	120Vac, 60Hz	Anderson Chen

3.3 Duty Cycle of Test Signal

Duty cycle of test signal is < 98%, duty factor shall be considered.

Duty cycle = $21.937/510.75 = 0.043$

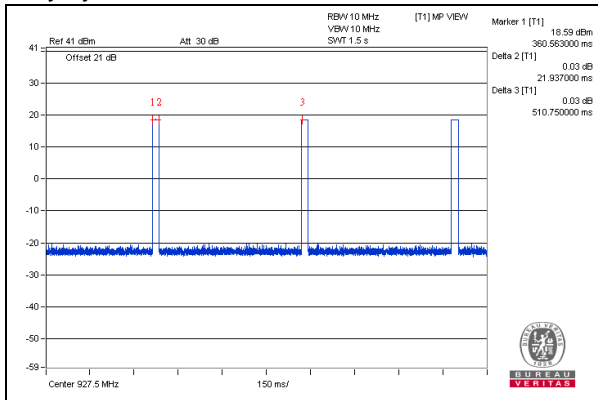

3.4 Description of Support Units

The EUT has been tested as an independent unit together with other necessary accessories or support units. The following support units or accessories were used to form a representative test configuration during the tests.

ID	Product	Brand	Model No.	Serial No.	FCC ID	Remarks
A.	Laptop	DELL	E5430	HYV4VY1	FCC DoC	Provided by Lab
B.	Laptop	DELL	E6420	B92T3R1	FCC DoC	Provided by Lab
C.	USB Disk 3.0	Transcend	16GB	NA	NA	Provided by Lab
D.	Sim Card	R&S	CRT-Z3	NA	NA	Provided by Lab

Note:

1. All power cords of the above support units are non-shielded (1.8m).

ID	Descriptions	Qty.	Length (m)	Shielding (Yes/No)	Cores (Qty.)	Remarks
1.	DC Cable	1	1.5	No	1	Supplied by client
2.	Console Cable	1	1.6	No	0	Provided by Lab
3.	RJ-45 Cable	1	10	No	0	Provided by Lab
4.	RJ-45 Cable	1	10	No	0	Provided by Lab
5.	AC Cable	1	1.8	No	0	Supplied by client

Note: The core(s) is(are) originally attached to the cable(s).

3.4.1 Configuration of System under Test

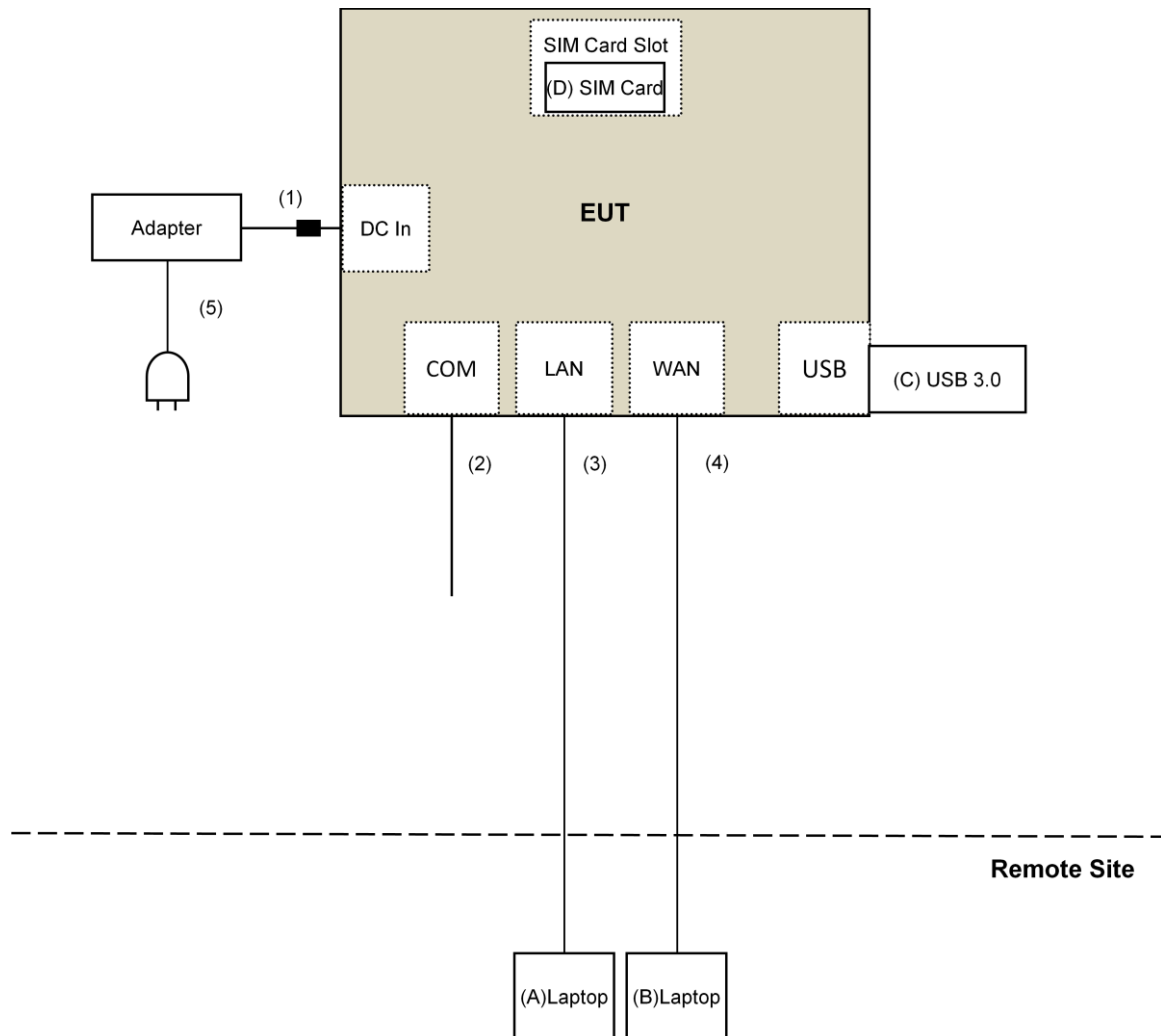

3.5 General Description of Applied Standards

The EUT is a RF Product. According to the specifications of the manufacturer, it must comply with the requirements of the following standards:

FCC Part 15, Subpart C (15.247)

KDB 558074 D01 DTS Meas Guidance v04

ANSI C63.10-2013

All test items have been performed and recorded as per the above standards.

NOTE: The EUT has been verified to comply with the requirements of FCC Part 15, Subpart B, Class B (DoC). The test report has been issued separately.

4 Test Types and Results

4.1 Radiated Emission and Bandedge Measurement

4.1.1 Limits of Radiated Emission and Bandedge Measurement

Radiated emissions which fall in the restricted bands must comply with the radiated emission limits specified as below table. Other emissions shall be at least 20dB below the highest level of the desired power:

Frequencies (MHz)	Field Strength (microvolts/meter)	Measurement Distance (meters)
0.009 ~ 0.490	2400/F(kHz)	300
0.490 ~ 1.705	24000/F(kHz)	30
1.705 ~ 30.0	30	30
30 ~ 88	100	3
88 ~ 216	150	3
216 ~ 960	200	3
Above 960	500	3

NOTE:

1. The lower limit shall apply at the transition frequencies.
2. Emission level (dBuV/m) = 20 log Emission level (uV/m).
3. For frequencies above 1000MHz, the field strength limits are based on average detector, however, the peak field strength of any emission shall not exceed the maximum permitted average limits, specified above by more than 20dB under any condition of modulation.

4.1.2 Test Instruments

For below 1GHz test:

DESCRIPTION & MANUFACTURER	MODEL NO.	SERIAL NO.	CALIBRATED DATE	CALIBRATED UNTIL
Test Receiver Keysight	N9038A	MY54450088	July 20, 2016	July 19, 2017
Pre-Amplifier ^(*) EMCI	EMC001340	980142	Jan. 20, 2016	Jan. 19, 2018
Loop Antenna ^(*) Electro-Metrics	EM-6879	264	Dec. 16, 2016	Dec. 15, 2018
RF Cable	NA	LOOPCAB-001 LOOPCAB-002	Jan. 17, 2017	Jan. 16, 2018
Pre-Amplifier Mini-Circuits	ZFL-1000VH2B	AMP-ZFL-01	Nov. 10, 2016	Nov. 09, 2017
Trilog Broadband Antenna SCHWARZBECK	VULB 9168	9168-406	Dec. 13, 2016	Dec. 12, 2017
RF Cable	8D	966-4-1 966-4-2 966-4-3	Apr. 01, 2017	Mar. 31, 2018
Fixed attenuator Mini-Circuits	UNAT-5+	PAD-3m-4-01	Oct. 05, 2016	Oct. 04, 2017
Software	ADT_Radiated_V8.7.08	NA	NA	NA
Antenna Tower & Turn Table Max-Full	MF-7802	MF780208410	NA	NA

Note:

1. The calibration interval of the above test instruments is 12 months and the calibrations are traceable to NML/ROC and NIST/USA.
2. The test was performed in 966 Chamber No. 4.
3. The FCC Site Registration No. is 292998
4. The CANADA Site Registration No. is 20331-2
5. Tested Date: June 30, 2017

For above 1GHz test:

DESCRIPTION & MANUFACTURER	MODEL NO.	SERIAL NO.	CALIBRATED DATE	CALIBRATED UNTIL
Test ReceiverKeysight	N9038A	MY54450088	July 08, 2017	July 07, 2018
Pre-Amplifier ^(*) EMCI	EMC001340	980142	Jan. 20, 2016	Jan. 19, 2018
Horn_Antenna SCHWARZBECK	BBHA 9120D	9120D-783	Dec. 27, 2016	Dec. 26, 2017
Pre-Amplifier EMCI	EMC12630SE	980385	Feb. 02, 2017	Feb. 01, 2018
RF Cable	EMC104-SM-SM-1 200 EMC104-SM-SM-2 000 EMC104-SM-SM-5 000	160923 150318 150321	Feb. 02, 2017 Mar. 29, 2017 Mar. 29, 2017	Feb. 01, 2018 Mar. 28, 2018 Mar. 28, 2018
Pre-Amplifier EMCI	EMC184045SE	980387	Feb. 02, 2017	Feb. 01, 2018
Horn_Antenna SCHWARZBECK	BBHA 9170	BBHA9170608	Dec. 15, 2016	Dec. 14, 2017
RF Cable	SUCOFLEX 102	36432/2 36433/2	Jan. 15, 2017	Jan. 14, 2018
Software	ADT_Radiated_V8. 7.08	NA	NA	NA
Antenna Tower & Turn Table Max-Full	MF-7802	MF780208410	NA	NA
Boresight Antenna Fixture	FBA-01	FBA-SIP02	NA	NA
Spectrum Analyzer R&S	FSP40	100964	July 01, 2017	June 30, 2018
Power meter Anritsu	ML2495A	MY48250253	Dec. 21, 2016	Dec. 20, 2017
Power sensor Anritsu	MA2411B	1014008	May 11, 2017	May 10, 2018

NOTE:

1. The calibration interval of the above test instruments is 12 months and the calibrations are traceable to NML/ROC and NIST/USA.
2. *The calibration interval of the above test instruments is 24 months and the calibrations are traceable to NML/ROC and NIST/USA.
3. The test was performed in 966 Chamber No. 4.
4. The CANADA Site Registration No. is 20331-2
5. Loop antenna was used for all emissions below 30 MHz.
6. Tested Date: July 26 to 27, 2017.

4.1.3 Test Procedures

For Radiated emission below 30MHz

- a. The EUT was placed on the top of a rotating table 0.8 meters above the ground at a 3 meter chamber room. The table was rotated 360 degrees to determine the position of the highest radiation.
- b. The EUT was set 3 meters away from the interference-receiving antenna, which was mounted on the top of a variable-height antenna tower.
- c. Both X and Y axes of the antenna are set to make the measurement.
- d. For each suspected emission, the EUT was arranged to its worst case and the rotatable table was turned from 0 degrees to 360 degrees to find the maximum reading.
- e. The test-receiver system was set to Quasi-Peak Detect Function and Specified Bandwidth with Maximum Hold Mode.

NOTE:

1. The resolution bandwidth and video bandwidth of test receiver/spectrum analyzer is 9kHz at frequency below 30MHz.

For Radiated emission above 30MHz

- a. The EUT was placed on the top of a rotating table 0.8 meters (for 30MHz ~ 1GHz) / 1.5 meters (for above 1GHz) above the ground at 3 meter chamber room for test. The table was rotated 360 degrees to determine the position of the highest radiation.
- b. The EUT was set 3 meters away from the interference-receiving antenna, which was mounted on the top of a variable-height antenna tower.
- c. The height of antenna is varied from one meter to four meters above the ground to determine the maximum value of the field strength. Both horizontal and vertical polarizations of the antenna are set to make the measurement.
- d. For each suspected emission, the EUT was arranged to its worst case and then the antenna was tuned to heights from 1 meter to 4 meters and the rotatable table was turned from 0 degrees to 360 degrees to find the maximum reading.
- e. The test-receiver system was set to quasi-peak detect function and specified bandwidth with maximum hold mode when the test frequency is below 1 GHz.
- f. The test-receiver system was set to peak and average detect function and specified bandwidth with maximum hold mode when the test frequency is above 1 GHz. If the peak reading value also meets average limit, measurement with the average detector is unnecessary.

Note:

1. The resolution bandwidth and video bandwidth of test receiver/spectrum analyzer is 120kHz for Quasi-peak detection (QP) at frequency below 1GHz.
2. The resolution bandwidth of test receiver/spectrum analyzer is 1 MHz and the video bandwidth is 3 MHz for Peak detection (PK) at frequency above 1GHz.
3. The resolution bandwidth of test receiver/spectrum analyzer is 1MHz and the video bandwidth is $\geq 1/T$ (Duty cycle < 98%) or 10Hz (Duty cycle $\geq 98\%$) for Average detection (AV) at frequency above 1GHz.
4. All modes of operation were investigated and the worst-case emissions are reported.

4.1.4 Deviation from Test Standard

No deviation.

4.1.5 Test Setup

For Radiated emission below 30MHz

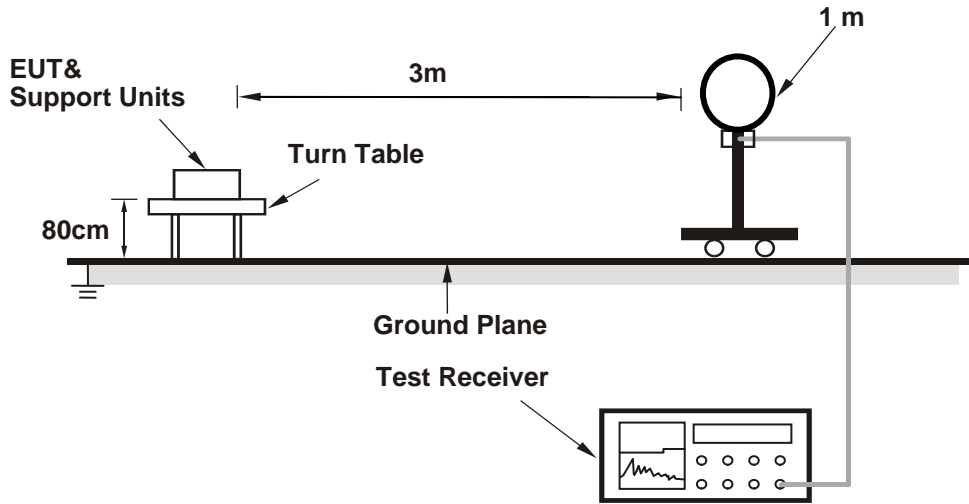

For Radiated emission 30MHz to 1GHz

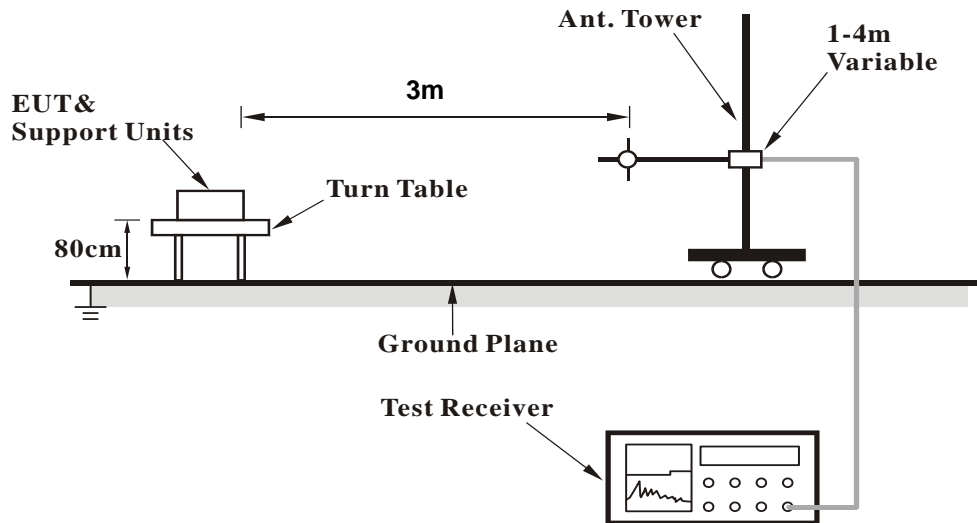

For Radiated emission above 1GHz

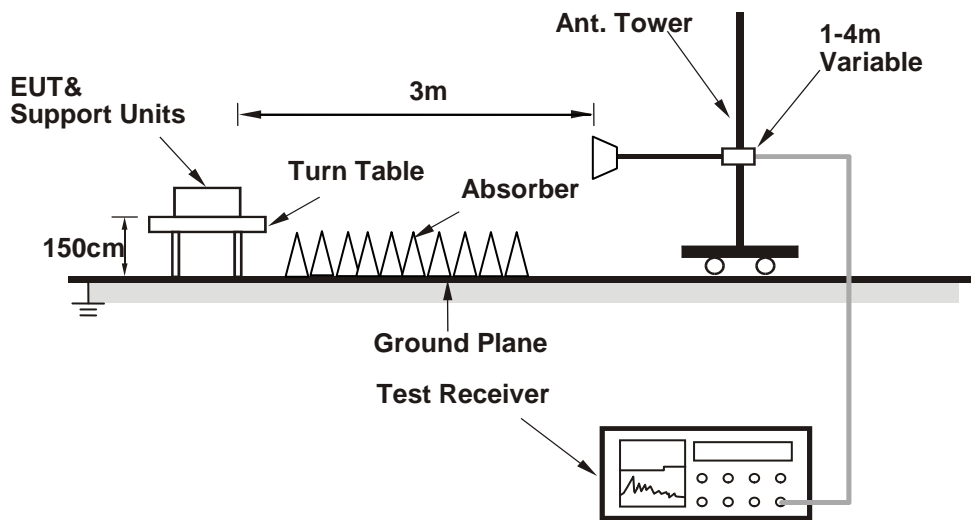

For the actual test configuration, please refer to the attached file (Test Setup Photo).

4.1.6 EUT Operating Conditions

- a. Placed the EUT on the testing table.
- b. Controlling software (Hyperterminal pasted command) has been activated to set the EUT on specific status.

4.1.7 Test Results

Above 1GHz Data :

CHANNEL	TX Channel 0	DETECTOR FUNCTION	Peak (PK)
FREQUENCY RANGE	1GHz ~ 10GHz		Average (AV)

ANTENNA POLARITY & TEST DISTANCE: HORIZONTAL AT 3 M

NO.	FREQ. (MHz)	EMISSION LEVEL (dBuV/m)	LIMIT (dBuV/m)	MARGIN (dB)	ANTENNA HEIGHT (m)	TABLE ANGLE (Degree)	RAW VALUE (dBuV)	CORRECTION FACTOR (dB/m)
1	1846.60	45.4 PK	74.0	-28.6	1.21 H	109	48.9	-3.5
2	1846.60	20.2 AV	54.0	-33.8	1.21 H	109	23.7	-3.5
3	2769.90	48.0 PK	74.0	-26.0	1.21 H	109	48.4	-0.4
4	2769.90	22.8 AV	54.0	-31.2	1.21 H	109	23.2	-0.4
5	3693.20	41.8 PK	74.0	-32.2	2.57 H	214	40.6	1.2
6	3693.20	16.6 AV	54.0	-37.4	2.57 H	214	15.4	1.2
7	4616.50	41.6 PK	74.0	-32.4	2.71 H	27	38.9	2.7
8	4616.50	16.4 AV	54.0	-37.6	2.71 H	27	13.7	2.7
9	5539.80	41.9 PK	74.0	-32.1	1.33 H	355	37.4	4.5
10	5539.80	16.7 AV	54.0	-37.3	1.33 H	355	12.2	4.5
11	6463.10	42.7 PK	74.0	-31.3	3.47 H	329	35.6	7.1
12	6463.10	17.5 AV	54.0	-36.5	3.47 H	329	10.4	7.1
13	7386.40	48.0 PK	74.0	-26.0	1.40 H	200	38.1	9.9
14	7386.40	22.8 AV	54.0	-31.2	1.40 H	200	12.9	9.9
15	8309.70	53.5 PK	74.0	-20.5	3.49 H	353	42.4	11.1
16	8309.70	28.3 AV	54.0	-25.7	3.49 H	353	17.2	11.1
17	9233.00	48.2 PK	74.0	-25.8	1.05 H	164	37.2	11.0
18	9233.00	23.0 AV	54.0	-31.0	1.05 H	164	12.0	11.0

ANTENNA POLARITY & TEST DISTANCE: VERTICAL AT 3 M

NO.	FREQ. (MHz)	EMISSION LEVEL (dBuV/m)	LIMIT (dBuV/m)	MARGIN (dB)	ANTENNA HEIGHT (m)	TABLE ANGLE (Degree)	RAW VALUE (dBuV)	CORRECTION FACTOR (dB/m)
1	1846.60	64.0 PK	74.0	-10.0	1.00 V	268	67.5	-3.5
2	1846.60	38.8 AV	54.0	-15.2	1.00 V	268	42.3	-3.5
3	2769.90	57.3 PK	74.0	-16.7	1.00 V	69	57.7	-0.4
4	2769.90	32.1 AV	54.0	-21.9	1.00 V	69	32.5	-0.4
5	3693.20	49.7 PK	74.0	-24.3	1.58 V	223	48.5	1.2
6	3693.20	24.5 AV	54.0	-29.5	1.58 V	223	23.3	1.2
7	4616.50	46.1 PK	74.0	-27.9	1.00 V	126	43.4	2.7
8	4616.50	20.9 AV	54.0	-33.1	1.00 V	126	18.2	2.7
9	5539.80	45.6 PK	74.0	-28.4	1.53 V	286	41.1	4.5
10	5539.80	20.4 AV	54.0	-33.6	1.53 V	286	15.9	4.5
11	6463.10	45.5 PK	74.0	-28.5	1.14 V	75	38.4	7.1
12	6463.10	20.3 AV	54.0	-33.7	1.14 V	75	13.2	7.1
13	7386.40	51.9 PK	74.0	-22.1	1.50 V	265	42.0	9.9
14	7386.40	26.7 AV	54.0	-27.3	1.50 V	265	16.8	9.9
15	8309.70	54.4 PK	74.0	-19.6	1.28 V	272	43.3	11.1
16	8309.70	29.2 AV	54.0	-24.8	1.28 V	272	18.1	11.1
17	9233.00	52.8 PK	74.0	-21.2	1.26 V	254	41.8	11.0
18	9233.00	27.6 AV	54.0	-26.4	1.26 V	254	16.6	11.0

REMARKS:

1. Emission Level(dBuV/m) = Raw Value(dBuV) + Correction Factor(dB/m)
2. Correction Factor(dB/m) = Antenna Factor(dB/m) + Cable Factor(dB) – Pre-Amplifier Factor(dB)
3. The other emission levels were very low against the limit.
4. Margin value = Emission Level – Limit value
5. " * ": Fundamental frequency.

CHANNEL	TX Channel 7	DETECTOR FUNCTION	Peak (PK)
FREQUENCY RANGE	1GHz ~ 10GHz		Average (AV)

ANTENNA POLARITY & TEST DISTANCE: HORIZONTAL AT 3 M

NO.	FREQ. (MHz)	EMISSION LEVEL (dBuV/m)	LIMIT (dBuV/m)	MARGIN (dB)	ANTENNA HEIGHT (m)	TABLE ANGLE (Degree)	RAW VALUE (dBuV)	CORRECTION FACTOR (dB/m)
1	1855.00	45.6 PK	74.0	-28.4	1.26 H	114	49.1	-3.5
2	1855.00	20.4 AV	54.0	-33.6	1.26 H	114	23.9	-3.5
3	2782.50	48.4 PK	74.0	-25.6	1.23 H	116	48.8	-0.4
4	2782.50	23.2 AV	54.0	-30.8	1.23 H	116	23.6	-0.4
5	3710.00	41.9 PK	74.0	-32.1	2.60 H	199	40.5	1.4
6	3710.00	16.7 AV	54.0	-37.3	2.60 H	199	15.3	1.4
7	4637.50	41.4 PK	74.0	-32.6	2.73 H	34	38.7	2.7
8	4637.50	16.2 AV	54.0	-37.8	2.73 H	34	13.5	2.7
9	5565.00	42.1 PK	74.0	-31.9	1.36 H	360	37.5	4.6
10	5565.00	16.9 AV	54.0	-37.1	1.36 H	360	12.3	4.6
11	6492.50	43.0 PK	74.0	-31.0	3.42 H	331	35.8	7.2
12	6492.50	17.8 AV	54.0	-36.2	3.42 H	331	10.6	7.2
13	7420.00	47.9 PK	74.0	-26.1	1.36 H	185	38.0	9.9
14	7420.00	22.7 AV	54.0	-31.3	1.36 H	185	12.8	9.9
15	8347.50	54.1 PK	74.0	-19.9	3.51 H	360	43.0	11.1
16	8347.50	28.9 AV	54.0	-25.1	3.51 H	360	17.8	11.1
17	9275.00	48.4 PK	74.0	-25.6	1.07 H	157	37.3	11.1
18	9275.00	23.2 AV	54.0	-30.8	1.07 H	157	12.1	11.1

ANTENNA POLARITY & TEST DISTANCE: VERTICAL AT 3 M

NO.	FREQ. (MHz)	EMISSION LEVEL (dBuV/m)	LIMIT (dBuV/m)	MARGIN (dB)	ANTENNA HEIGHT (m)	TABLE ANGLE (Degree)	RAW VALUE (dBuV)	CORRECTION FACTOR (dB/m)
1	1855.00	64.4 PK	74.0	-9.6	1.00 V	276	67.9	-3.5
2	1855.00	39.2 AV	54.0	-14.8	1.00 V	276	42.7	-3.5
3	2782.50	57.6 PK	74.0	-16.4	1.00 V	75	58.0	-0.4
4	2782.50	32.4 AV	54.0	-21.6	1.00 V	75	32.8	-0.4
5	3710.00	49.5 PK	74.0	-24.5	1.55 V	232	48.1	1.4
6	3710.00	24.3 AV	54.0	-29.7	1.55 V	232	22.9	1.4
7	4637.50	45.9 PK	74.0	-28.1	1.00 V	124	43.2	2.7
8	4637.50	20.7 AV	54.0	-33.3	1.00 V	124	18.0	2.7
9	5565.00	45.7 PK	74.0	-28.3	1.55 V	295	41.1	4.6
10	5565.00	20.5 AV	54.0	-33.5	1.55 V	295	15.9	4.6
11	6492.50	45.9 PK	74.0	-28.1	1.14 V	84	38.7	7.2
12	6492.50	20.7 AV	54.0	-33.3	1.14 V	84	13.5	7.2
13	7420.00	51.6 PK	74.0	-22.4	1.49 V	253	41.7	9.9
14	7420.00	26.4 AV	54.0	-27.6	1.49 V	253	16.5	9.9
15	8347.50	54.0 PK	74.0	-20.0	1.32 V	278	42.9	11.1
16	8347.50	28.8 AV	54.0	-25.2	1.32 V	278	17.7	11.1
17	9275.00	52.4 PK	74.0	-21.6	1.27 V	253	41.3	11.1
18	9275.00	27.2 AV	54.0	-26.8	1.27 V	253	16.1	11.1

REMARKS:

1. Emission Level(dBuV/m) = Raw Value(dBuV) + Correction Factor(dB/m)
2. Correction Factor(dB/m) = Antenna Factor(dB/m) + Cable Factor(dB) – Pre-Amplifier Factor(dB)
3. The other emission levels were very low against the limit.
4. Margin value = Emission Level – Limit value
5. " * ": Fundamental frequency.

Below 1GHz Data:

CHANNEL	TX Channel 0	DETECTOR FUNCTION	Quasi-Peak (QP)
FREQUENCY RANGE	9kHz ~ 1GHz		

ANTENNA POLARITY & TEST DISTANCE: HORIZONTAL AT 3 M								
NO.	FREQ. (MHz)	EMISSION LEVEL (dBuV/m)	LIMIT (dBuV/m)	MARGIN (dB)	ANTENNA HEIGHT (m)	TABLE ANGLE (Degree)	RAW VALUE (dBuV)	CORRECTION FACTOR (dB/m)
1	62.20	30.8 QP	40.0	-9.2	1.50 H	360	39.8	-9.0
2	141.48	33.5 QP	43.5	-10.0	2.00 H	103	41.7	-8.2
3	190.58	34.9 QP	43.5	-8.6	2.00 H	63	45.8	-10.9
4	342.05	34.8 QP	46.0	-11.2	1.00 H	352	41.4	-6.6
5	671.92	39.8 QP	46.0	-6.2	1.00 H	24	39.4	0.4
6	813.35	36.3 QP	46.0	-9.7	1.00 H	333	33.7	2.6
7	902.00	41.5 QP	92.0	-50.5	1.51 H	90	10.2	31.3
8	*923.30	112.0 QP			1.51 H	90	80.4	31.6

ANTENNA POLARITY & TEST DISTANCE: VERTICAL AT 3 M								
NO.	FREQ. (MHz)	EMISSION LEVEL (dBuV/m)	LIMIT (dBuV/m)	MARGIN (dB)	ANTENNA HEIGHT (m)	TABLE ANGLE (Degree)	RAW VALUE (dBuV)	CORRECTION FACTOR (dB/m)
1	34.83	35.9 QP	40.0	-4.1	3.00 V	236	44.9	-9.0
2	63.37	30.8 QP	40.0	-9.2	2.50 V	360	39.6	-8.8
3	142.52	30.8 QP	43.5	-12.7	1.00 V	246	38.9	-8.1
4	191.36	35.2 QP	43.5	-8.3	1.00 V	261	46.2	-11.0
5	671.99	40.4 QP	46.0	-5.6	1.50 V	50	40.0	0.4
6	816.33	38.9 QP	46.0	-7.1	1.00 V	20	36.2	2.7
7	902.00	41.7 QP	100.0	-58.3	1.04 V	71	10.4	31.3
8	*923.30	120.0 QP			1.04 V	71	88.4	31.6

REMARKS:

1. Emission Level(dBuV/m) = Raw Value(dBuV) + Correction Factor(dB/m)
2. Correction Factor(dB/m) = Antenna Factor(dB/m) + Cable Factor(dB) – Pre-Amplifier Factor(dB)
3. The other emission levels were very low against the limit.
4. Margin value = Emission Level – Limit value
5. " * ": Fundamental frequency.

CHANNEL	TX Channel 7	DETECTOR FUNCTION	Quasi-Peak (QP)
FREQUENCY RANGE	9kHz ~ 1GHz		

ANTENNA POLARITY & TEST DISTANCE: HORIZONTAL AT 3 M

NO.	FREQ. (MHz)	EMISSION LEVEL (dBuV/m)	LIMIT (dBuV/m)	MARGIN (dB)	ANTENNA HEIGHT (m)	TABLE ANGLE (Degree)	RAW VALUE (dBuV)	CORRECTION FACTOR (dB/m)
1	63.45	31.7 QP	40.0	-8.3	2.00 H	64	40.5	-8.8
2	142.31	34.7 QP	43.5	-8.8	2.00 H	87	42.8	-8.1
3	191.65	35.6 QP	43.5	-7.9	1.50 H	69	46.7	-11.1
4	394.79	32.3 QP	46.0	-13.7	1.50 H	360	37.7	-5.4
5	614.86	33.3 QP	46.0	-12.7	1.50 H	52	33.5	-0.2
6	672.00	42.9 QP	46.0	-3.1	2.50 H	59	42.5	0.4
7	*927.50	112.7 QP			1.51 H	90	81.0	31.7
8	928.00	70.9 QP	92.7	-21.8	1.51 H	90	39.2	31.7

ANTENNA POLARITY & TEST DISTANCE: VERTICAL AT 3 M

NO.	FREQ. (MHz)	EMISSION LEVEL (dBuV/m)	LIMIT (dBuV/m)	MARGIN (dB)	ANTENNA HEIGHT (m)	TABLE ANGLE (Degree)	RAW VALUE (dBuV)	CORRECTION FACTOR (dB/m)
1	34.15	35.9 QP	40.0	-4.1	3.00 V	120	44.7	-8.8
2	63.40	30.5 QP	40.0	-9.5	2.50 V	28	39.3	-8.8
3	87.16	27.5 QP	40.0	-12.5	2.00 V	39	41.6	-14.1
4	191.50	35.2 QP	43.5	-8.3	1.00 V	200	46.2	-11.0
5	672.10	38.5 QP	46.0	-7.5	3.00 V	310	38.1	0.4
6	811.85	40.3 QP	46.0	-5.7	1.00 V	56	37.7	2.6
7	*927.50	120.4 QP			1.04 V	74	88.7	31.7
8	928.00	78.5 QP	100.4	-21.9	1.04 V	74	46.8	31.7

REMARKS:

1. Emission Level(dBuV/m) = Raw Value(dBuV) + Correction Factor(dB/m)
2. Correction Factor(dB/m) = Antenna Factor(dB/m) + Cable Factor(dB) – Pre-Amplifier Factor(dB)
3. The other emission levels were very low against the limit.
4. Margin value = Emission Level – Limit value
5. " * ": Fundamental frequency.

4.2 Conducted Emission Measurement

4.2.1 Limits of Conducted Emission Measurement

Frequency (MHz)	Conducted Limit (dBuV)	
	Quasi-peak	Average
0.15 - 0.5	66 - 56	56 - 46
0.50 - 5.0	56	46
5.0 - 30.0	60	50

Note: 1. The lower limit shall apply at the transition frequencies.

2. The limit decreases in line with the logarithm of the frequency in the range of 0.15 to 0.50MHz.

4.2.2 Test Instruments

DESCRIPTION & MANUFACTURER	MODEL NO.	SERIAL NO.	CALIBRATED DATE	CALIBRATED UNTIL
Test Receiver R&S	ESCS 30	847124/029	Oct. 24, 2016	Oct. 23, 2017
Line-Impedance Stabilization Network (for EUT) R&S	ESH3-Z5	848773/004	Oct. 26, 2016	Oct. 25, 2017
Line-Impedance Stabilization Network (for Peripheral) R&S	ENV216	100072	June 03, 2017	June 02, 2018
50 ohms Terminator	N/A	EMC-02	Sep. 29, 2016	Sep. 28, 2017
RF Cable	5D-FB	COCCAB-001	Sep. 30, 2016	Sep. 29, 2017
10 dB PAD Mini-Circuits	HAT-10+	CONATT-004	June 18, 2017	June 17, 2018
Software BVADT	BVADT_Cond_V7.3.7.4	NA	NA	NA

Note:

1. The calibration interval of the above test instruments are 12 months and the calibrations are traceable to NML/ROC and NIST/USA.
2. The test was performed in Shielded Room No. 1.
3. Tested Date: July 18, 2017.

4.2.3 Test Procedures

- The EUT was placed 0.4 meters from the conducting wall of the shielded room with EUT being connected to the power mains through a line impedance stabilization network (LISN). Other support units were connected to the power mains through another LISN. The two LISNs provide 50 ohm/ 50uH of coupling impedance for the measuring instrument.
- Both lines of the power mains connected to the EUT were checked for maximum conducted interference.
- The frequency range from 150kHz to 30MHz was searched. Emission levels under (Limit - 20dB) was not recorded.

NOTE: The resolution bandwidth and video bandwidth of test receiver is 9kHz for quasi-peak detection (QP) and average detection (AV) at frequency 0.15MHz-30MHz.

4.2.4 Deviation from Test Standard

No deviation.

4.2.5 Test Setup

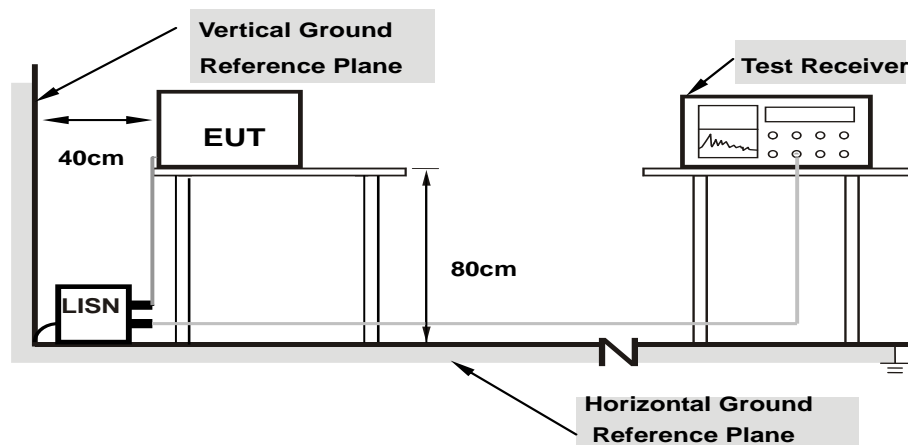

Note: 1.Support units were connected to second LISN.

For the actual test configuration, please refer to the attached file (Test Setup Photo).

4.2.6 EUT Operating Conditions

Same as 4.1.6.

4.2.7 Test Results

Phase	Line (L)	Detector Function	Quasi-Peak (QP) / Average (AV)
-------	----------	-------------------	--------------------------------

No	Freq.	Corr.	Reading Value		Emission Level		Limit		Margin	
	[MHz]	Factor	[dB (uV)]		[dB (uV)]		[dB (uV)]		(dB)	
		(dB)	Q.P.	AV.	Q.P.	AV.	Q.P.	AV.	Q.P.	AV.
1	0.15391	10.07	36.18	20.04	46.25	30.11	65.79	55.79	-19.54	-25.68
2	0.18516	10.06	31.05	17.53	41.11	27.59	64.25	54.25	-23.14	-26.66
3	0.22422	10.07	24.42	12.40	34.49	22.47	62.66	52.66	-28.17	-30.19
4	0.44297	10.11	29.44	22.90	39.55	33.01	57.01	47.01	-17.46	-14.00
5	3.26172	10.24	10.25	3.50	20.49	13.74	56.00	46.00	-35.51	-32.26
6	19.33594	11.25	19.81	14.61	31.06	25.86	60.00	50.00	-28.94	-24.14

REMARKS:

1. Q.P. and AV. are abbreviations of quasi-peak and average individually.
2. The emission levels of other frequencies were very low against the limit.
3. Margin value = Emission level - Limit value
4. Correction factor = Insertion loss + Cable loss
5. Emission Level = Correction Factor + Reading Value.

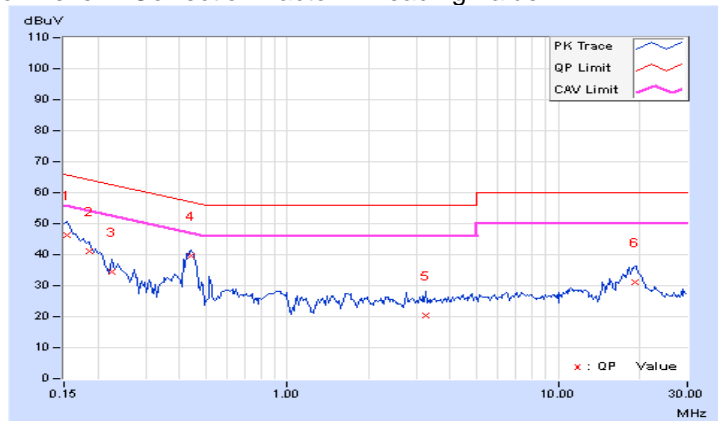

Phase	Neutral (N)	Detector Function	Quasi-Peak (QP) / Average (AV)
-------	-------------	-------------------	--------------------------------

No	Freq. [MHz]	Corr. Factor	Reading Value [dB (uV)]		Emission Level [dB (uV)]		Limit [dB (uV)]		Margin (dB)	
		(dB)	Q.P.	AV.	Q.P.	AV.	Q.P.	AV.	Q.P.	AV.
	1	0.16172	10.05	34.88	18.52	44.93	28.57	65.38	55.38	-20.45
2	0.17734	10.04	32.43	16.28	42.47	26.32	64.61	54.61	-22.14	-28.29
3	0.44297	10.10	27.90	21.07	38.00	31.17	57.01	47.01	-19.01	-15.84
4	0.48594	10.10	15.98	7.22	26.08	17.32	56.24	46.24	-30.16	-28.92
5	11.85938	10.64	12.72	6.79	23.36	17.43	60.00	50.00	-36.64	-32.57
6	18.80859	10.96	20.39	15.12	31.35	26.08	60.00	50.00	-28.65	-23.92

REMARKS:

1. Q.P. and AV. are abbreviations of quasi-peak and average individually.
2. The emission levels of other frequencies were very low against the limit.
3. Margin value = Emission level - Limit value
4. Correction factor = Insertion loss + Cable loss
5. Emission Level = Correction Factor + Reading Value.

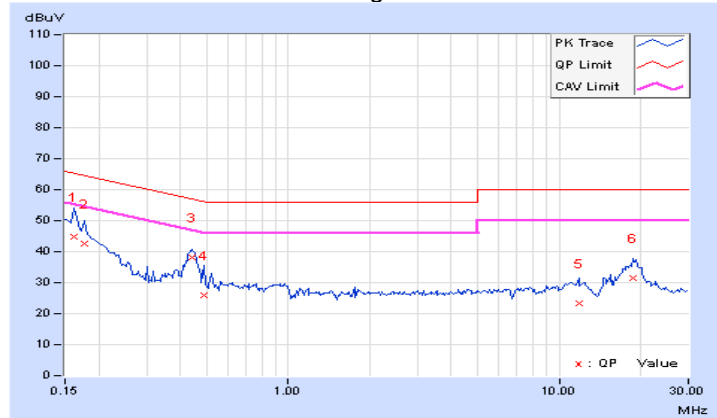

4.3 6dB Bandwidth Measurement

4.3.1 Limits of 6dB Bandwidth Measurement

The minimum of 6dB Bandwidth Measurement is 0.5 MHz.

4.3.2 Test Setup

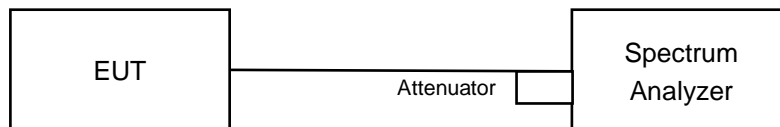

4.3.3 Test Instruments

Refer to section 4.1.2 to get information of above instrument.

4.3.4 Test Procedure

- Set resolution bandwidth (RBW) = 100kHz
- Set the video bandwidth (VBW) $\geq 3 \times$ RBW, Detector = Peak.
- Trace mode = max hold.
- Sweep = auto couple.
- Measure the maximum width of the emission that is constrained by the frequencies associated with the two amplitude points (upper and lower) that are attenuated by 6 dB relative to the maximum level measured in the fundamental emission

4.3.5 Deviation from Test Standard

No deviation.

4.3.6 EUT Operating Conditions

The software provided by client to enable the EUT under transmission condition continuously at lowest, middle and highest channel frequencies individually.

4.3.7 Test Result

Channel	Frequency (MHz)	6dB Bandwidth (MHz)	Minimum Limit (MHz)	Pass / Fail
0	923.3	0.72	0.5	Pass
7	927.5	0.72	0.5	Pass

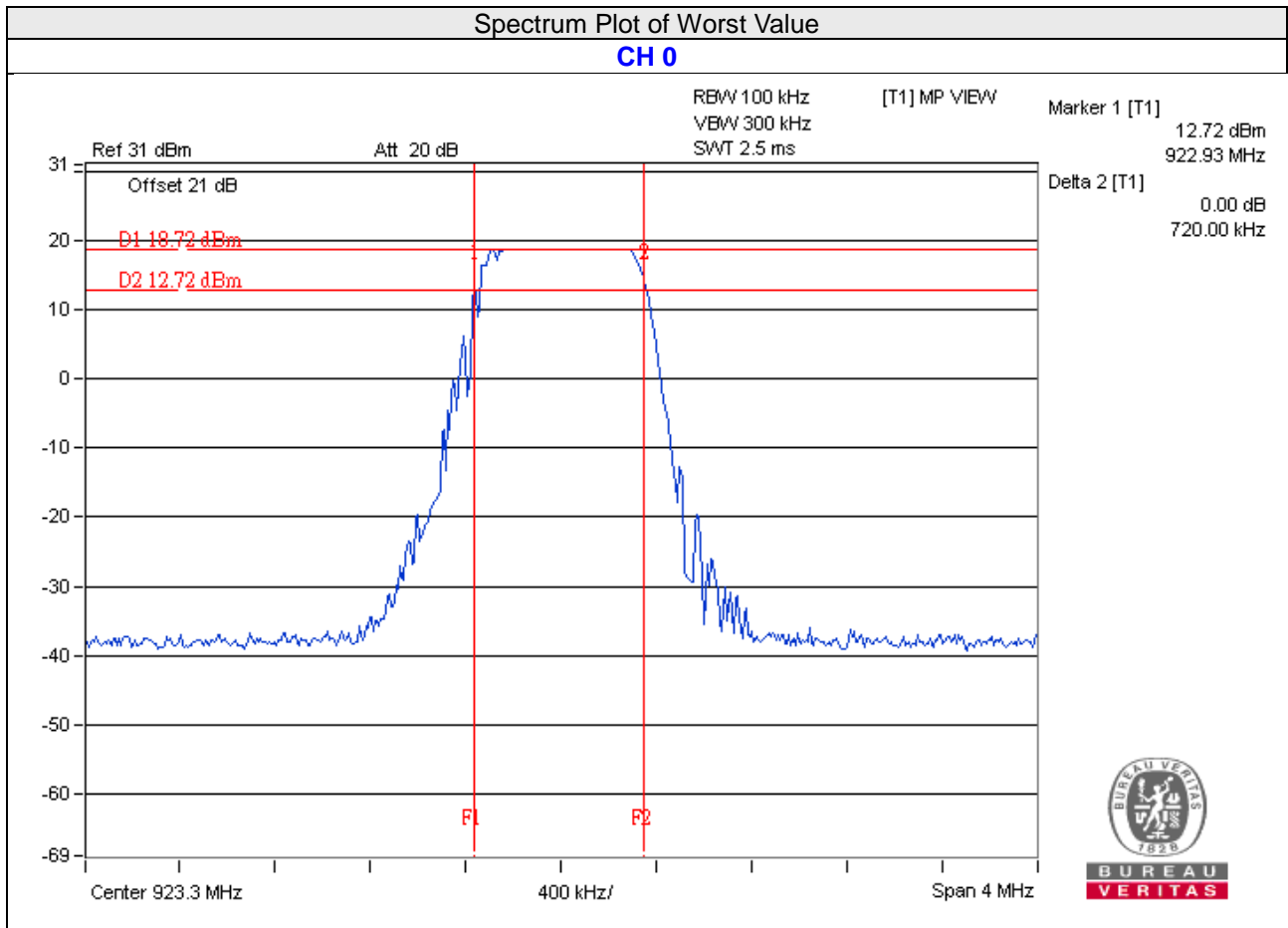

4.4 Conducted Output Power Measurement

4.4.1 Limits of Conducted Output Power Measurement

For systems using digital modulation in the 902–928 MHz bands: 1 Watt (30dBm)

4.4.2 Test Setup

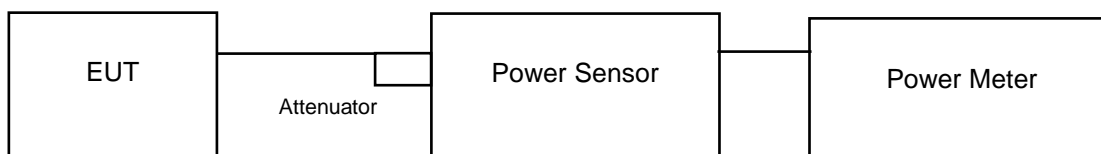

4.4.3 Test Instruments

Refer to section 4.1.2 to get information of above instrument.

4.4.4 Test Procedures

A peak / average power sensor was used on the output port of the EUT. A power meter was used to read the response of the peak / average power sensor. Record the power level.

4.4.5 Deviation from Test Standard

No deviation.

4.4.6 EUT Operating Conditions

Same as Item 4.3.6.

4.4.7 Test Results

FOR PEAK POWER

Channel	Frequency (MHz)	Peak Power (mW)	Peak Power (dBm)	Limit (dBm)	Pass/Fail
0	923.3	95.719	19.81	30	Pass
7	927.5	95.94	19.82	30	Pass

FOR AVERAGE POWER

Channel	Frequency (MHz)	Average Power (mW)	Average Power (dBm)
0	923.3	95.28	19.79
7	927.5	95.499	19.80

4.5 Power Spectral Density Measurement

4.5.1 Limits of Power Spectral Density Measurement

The Maximum of Power Spectral Density Measurement is 8dBm.

4.5.2 Test Setup

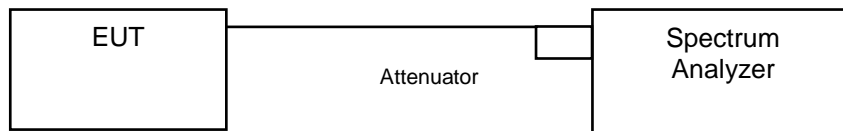

4.5.3 Test Instruments

Refer to section 4.1.2 to get information of above instrument.

4.5.4 Test Procedure

- a. Set analyzer center frequency to DTS channel center frequency.
- b. Set the span to 1.5 times the DTS bandwidth.
- c. Set the RBW to: $3 \text{ kHz} \leq \text{RBW} \leq 100 \text{ kHz}$.
- d. Set the VBW $\geq 3 \times \text{RBW}$.
- e. Detector = peak.
- f. Sweep time = auto couple.
- g. Trace mode = max hold.
- h. Allow trace to fully stabilize.
- i. Use the peak marker function to determine the maximum amplitude level within the RBW.

4.5.5 Deviation from Test Standard

No deviation.

4.5.6 EUT Operating Condition

Same as Item 4.3.6

4.5.7 Test Results

Channel	Freq. (MHz)	PSD (dBm/3kHz)	Limit (dBm/3kHz)	Pass /Fail
0	923.3	7.14	8	Pass
7	927.5	7.05	8	Pass

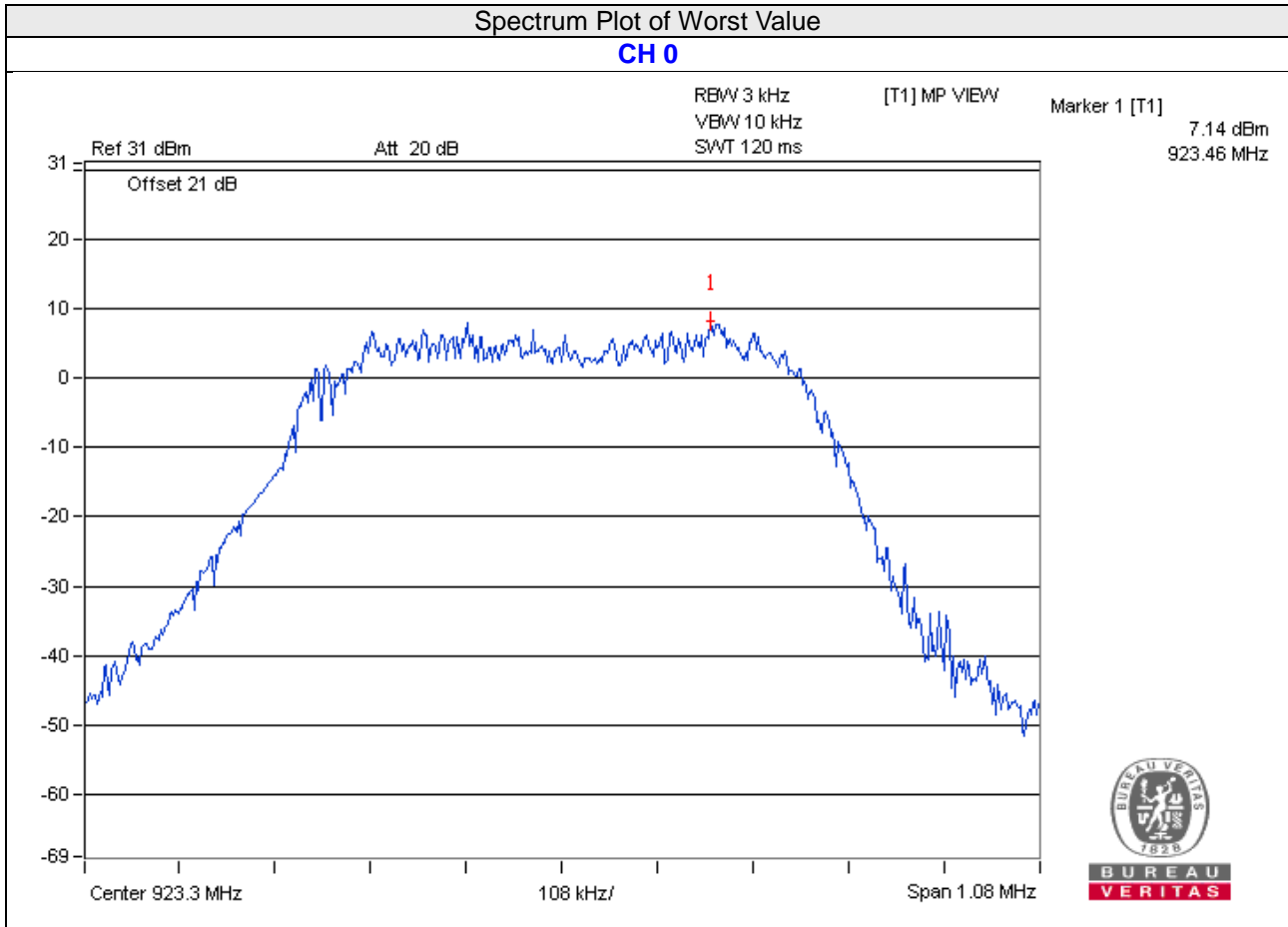

4.6 Conducted Out of Band Emission Measurement

4.6.1 Limits of Conducted Out of Band Emission Measurement

Below -20dB of the highest emission level of operating band (in 100kHz Resolution Bandwidth).

4.6.2 Test Setup

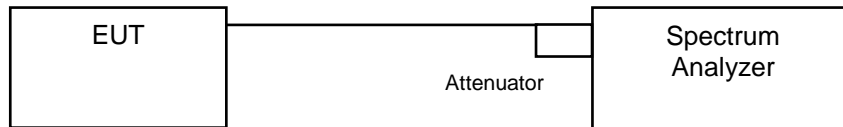

4.6.3 Test Instruments

Refer to section 4.1.2 to get information of above instrument.

4.6.4 Test Procedure

MEASUREMENT PROCEDURE REF

1. Set the RBW = 100 kHz.
2. Set the VBW \geq 300 kHz.
3. Detector = peak.
4. Sweep time = auto couple.
5. Trace mode = max hold.
6. Allow trace to fully stabilize.
7. Use the peak marker function to determine the maximum power level in any 100 kHz band segment within the fundamental EBW.

MEASUREMENT PROCEDURE OOBE

1. Set RBW = 100 kHz.
2. Set VBW \geq 300 kHz.
3. Detector = peak.
4. Sweep = auto couple.
5. Trace Mode = max hold.
6. Allow trace to fully stabilize.
7. Use the peak marker function to determine the maximum amplitude level.

4.6.5 Deviation from Test Standard

No deviation.

4.6.6 EUT Operating Condition

Same as Item 4.3.6

4.6.7 Test Results

CH 0

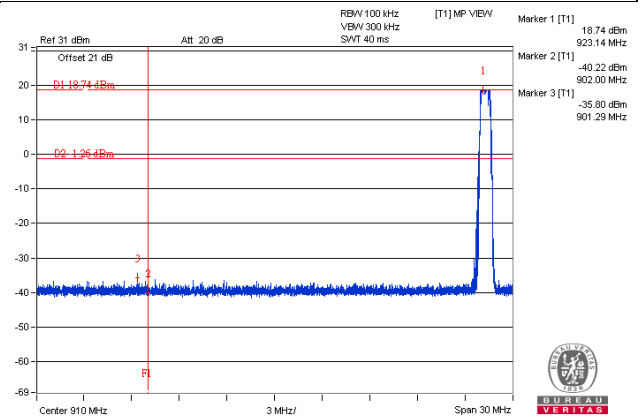
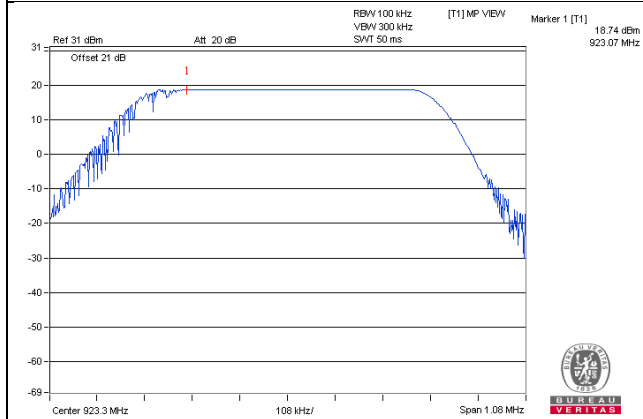

CH 7

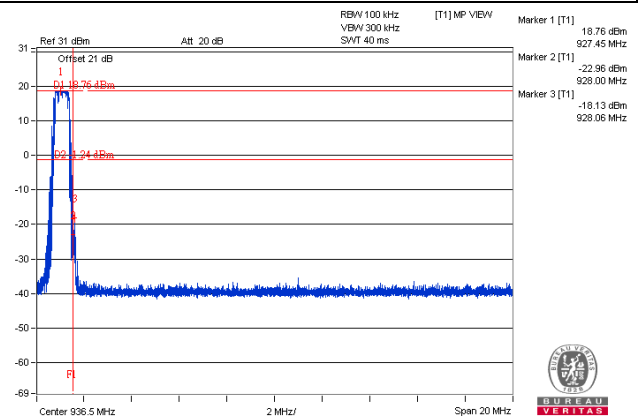
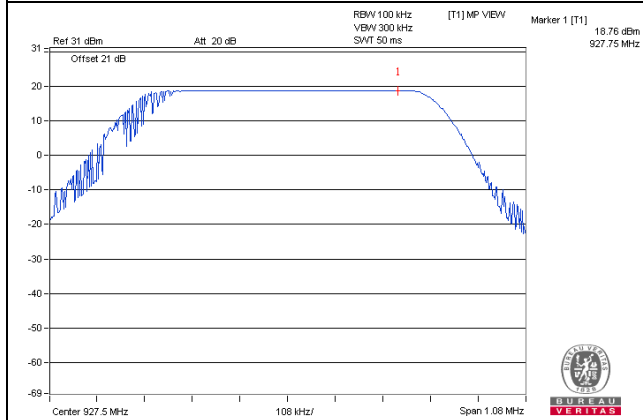

CH 0 Band edge

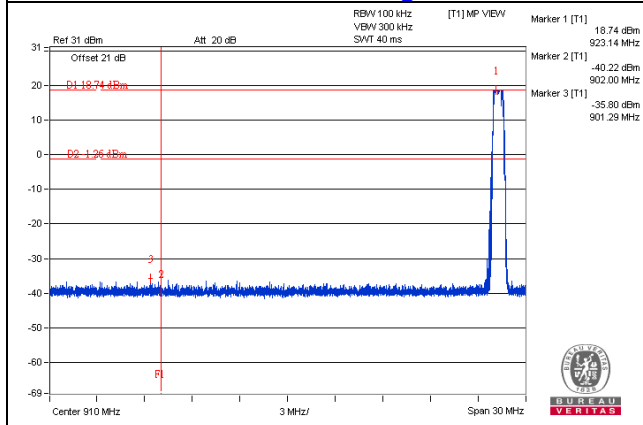

CH 7 Band edge

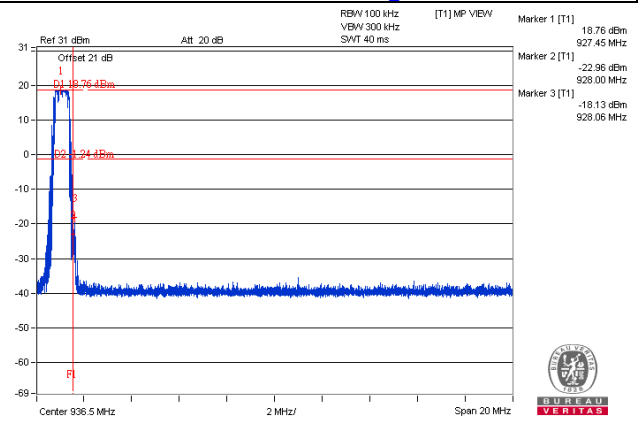

5 Pictures of Test Arrangements

Please refer to the attached file (Test Setup Photo).

Appendix – Information on the Testing Laboratories

We, Bureau Veritas Consumer Products Services (H.K.) Ltd., Taoyuan Branch, were founded in 1988 to provide our best service in EMC, Radio, Telecom and Safety consultation. Our laboratories are FCC recognized accredited test firms and accredited according to ISO/IEC 17025.

If you have any comments, please feel free to contact us at the following:

Linko EMC/RF Lab

Tel: 886-2-26052180

Fax: 886-2-26051924

Hsin Chu EMC/RF/Telecom Lab

Tel: 886-3-6668565

Fax: 886-3-6668323

Hwa Ya EMC/RF/Safety Lab

Tel: 886-3-3183232

Fax: 886-3-3270892

Email: service.adt@tw.bureauveritas.com

Web Site: www.bureauveritas-adt.com

The address and road map of all our labs can be found in our web site also.

--- END ---