

FCC TEST REPORT (PART 22)

REPORT NO.: 060625FIA01

MODEL NO.: M19

RECEIVED: Jun. 27, 2006

TESTED: Jun. 27 ~ Jul. 16, 2006

ISSUED: Jul. 17, 2006

APPLICANT: NINGBO BIRD CO., LTD.

ADDRESS: No. 999 Dacheng East Road, Fenghua City, Zhejiang

ISSUED BY: ADT (Shanghai) Corporation

ADDRESS: 2F, Building C, No.1618, Yishan Rd., 201103,
Shanghai, China

This test report consists of 76 pages in total. It may be duplicated completely for legal use with the approval of the applicant. It should not be reproduced except in full, without the written approval of our laboratory. The client should not use it to claim product endorsement by A2LA or any government agencies. The test results in the report only apply to the tested sample.

ADT (Shanghai) Corporation.





TABLE OF CONTENTS

1	CERTIFICATION	4
2	SUMMARY OF TEST RESULTS	5
2.1	MEASUREMENT UNCERTAINTY	6
3	GENERAL INFORMATION.....	7
3.1	GENERAL DESCRIPTION OF EUT	7
3.2	DESCRIPTION OF TEST MODES.....	8
3.3	GENERAL DESCRIPTION OF APPLIED STANDARDS	9
3.4	DESCRIPTION OF SUPPORT UNITS	9
4	TEST TYPES AND RESULTS	10
4.1	MODULATION CHARACTERISTICS.....	10
4.1.1	DESCRIPTION OF MODULATION TECHNIQUE	10
4.1.2	THE ACTIVE TIME SLOT 8 MODULATED FRAME PLOT.....	11
4.2	OUTPUT POWER MEASUREMENT	13
4.2.1	LIMITS OF OUTPUT POWER MEASUREMENT.....	13
4.2.2	TEST INSTRUMENTS.....	14
4.2.3	TEST PROCEDURES	15
4.2.4	TEST SETUP.....	16
4.2.5	EUT OPERATING CONDITIONS	17
4.2.6	TEST RESULTS	18
4.3	FREQUENCY STABILITY MEASUREMENT.....	22
4.3.1	LIMITS OF FREQUENCY STABILITY MEASUREMENT	22
4.3.2	TEST INSTRUMENTS.....	22
4.3.3	TEST PROCEDURE.....	23
4.3.4	TEST SETUP.....	24
4.3.5	TEST RESULTS	25
4.4	OCCUPIED BANDWIDTH MEASUREMENT.....	29
4.4.1	LIMITS OF OCCUPIED BANDWIDTH MEASUREMENT	29
4.4.2	TEST INSTRUMENTS.....	29
4.4.3	TEST SETUP.....	29
4.4.4	TEST PROCEDURES	30
4.4.5	EUT OPERATING CONDITION	30
4.4.6	TEST RESULTS	31
4.5	BAND EDGE MEASUREMENT.....	35
4.5.1	LIMITS OF BAND EDGE MEASUREMENT	35
4.5.2	TEST INSTRUMENTS.....	35
4.5.3	TEST SETUP.....	35
4.5.4	TEST PROCEDURES	36
4.5.5	EUT OPERATING CONDITION	36
4.5.6	TEST RESULTS	37



4.6	CONDUCTED SPURIOUS EMISSIONS	37
4.6.1	LIMITS OF CONDUCTED SPURIOUS EMISSIONS MEASUREMENT	39
4.6.2	TEST INSTRUMENTS.....	39
4.6.3	TEST PROCEDURE.....	40
4.6.4	TEST SETUP.....	40
4.6.5	EUT OPERATING CONDITIONS	40
4.6.6	TEST RESULTS	41
4.7	RADIATED EMISSION MEASUREMENT (BELOW 1GHZ)	59
4.7.1	LIMITS OF RADIATED EMISSION MEASUREMENT	59
4.7.2	TEST INSTRUMENTS.....	60
4.7.3	TEST PROCEDURES	61
4.7.4	DEVIATION FROM TEST STANDARD	61
4.7.5	TEST SETUP.....	62
4.7.6	EUT OPERATING CONDITIONS	62
4.7.7	TEST RESULTS	63
4.8	EFFECTIVE RADIATED POWER MEASUREMENT (ABOVE 1GHZ)	66
4.8.1	LIMITS OF RADIATED EMISSION MEASUREMENT	66
4.8.2	TEST INSTRUMENTS.....	67
4.8.3	TEST PROCEDURES	68
4.8.4	DEVIATION FROM TEST STANDARD	68
4.8.5	TEST SETUP.....	69
4.8.6	EUT OPERATING CONDITIONS	69
4.8.7	TEST RESULTS	70
5	INFORMATION ON THE TESTING LABORATORIES	76



1 CERTIFICATION

PRODUCT : Dual Band GSM GPRS Mobile Phone
MODEL NO. : M19
BRANDNAME : BIRD
APPLICANT : NINGBO BIRD CO., LTD
TESTED : Jun. 27 ~ Jul. 16, 2006
TEST SAMPLE : MASS PRODUCTION
TEST STANDARDS : FCC Part 22, Subpart H
ANSI C 63.4-2003

The above equipment has been tested by **ADT (Shanghai) Corporation**, and found compliance with the requirement of the above standards. The test record, data evaluation & Equipment Under Test (EUT) configurations represented herein are true and accurate accounts of the measurements of the sample's EMC characteristics under the conditions specified in this report.

TECHNICAL

ACCEPTANCE : _____ , **DATE:** JUL. 17, 2006
Steven Qian
Engineering Supervisor

APPROVED BY : _____ , **DATE:** JUL. 17, 2006
Wallace Pan
Director of Operations



2 SUMMARY OF TEST RESULTS

The EUT has been tested according to the following specifications:

APPLIED STANDARD: FCC Part 22 & Part 2 / IC RSS-132			
STANDARD SECTION	TEST TYPE AND LIMIT	RESULT	REMARK
2.1047 (d)	Modulation Characteristics	PASS	N/A
2.1046 22.913 (a)	Maximum Peak Output Power Limit: max. 7 watts e.r.p peak power	PASS	Meet the requirement of limit.
2.1055	Frequency Stability AFC Freq. Error vs. Voltage AFC Freq. Error vs. Temperature Limit: max. ± 2.5 ppm	PASS	Meet the requirement of limit.
2.1049 (h)	Occupied Bandwidth	PASS	Meet the requirement of limit.
22.917	Band Edge Measurements	PASS	N/A
2.1051 22.917	Conducted Spurious Emissions	PASS	Meet the requirement of limit. Minimum passing margin is -35.95 dB at 2548.00MHz.
2.1053 22.917	Radiated Spurious Emissions	PASS	Meet the requirement of limit. Minimum passing margin is -3.02 dB at 34.73MHz.

2.1 MEASUREMENT UNCERTAINTY

Where relevant, the following measurement uncertainty levels have been estimated for tests performed on the EUT as specified in CISPR 16-4:

MEASUREMENT	FREQUENCY	UNCERTAINTY
Conducted emissions	9kHz ~ 30MHz	2.44 dB
Radiated emissions	30MHz ~ 200MHz	3.73 dB
	200MHz ~1000MHz	3.74 dB
	1GHz ~ 18GHz	2.20 dB
	18GHz ~ 40GHz	1.88 dB

3 GENERAL INFORMATION

3.1 GENERAL DESCRIPTION OF EUT

PRODUCT	Dual Band GSM GPRS Mobile Phone
MODEL NO.	M19
POWER SUPPLY	3.9Vdc from rechargeable lithium battery Brand: SAGEM Model: BD-L4C
	5Vdc from power adapter Brand: SAGEM Model: DCH3-050US I/P: 110-230Vac, 0.12A, 50/60Hz O/P: 5.0Vdc, 500mA
MODULATION TYPE	GMSK for GSM, GPRS
FREQUENCY RANGE	Tx Frequency: 824 MHz ~ 849 MHz (GSM band) Rx Frequency: 869 MHz ~ 894 MHz (GSM band)
NUMBER OF CHANNEL	124
MAX. CONDUCTED PEAK OUTPUT POWER	GSM Mode: 33.20dBm (2.089Watts) GPRS Mode: 31.6dBm (1.445Watts)
MAX. RADITED ERP PEAK OUTPUT POWER	GSM Mode: 26.33dBm (0.430Watts) GPRS Mode: 24.28dBm (0.268Watts)
E AND I OF THE FINAL OUTPUT STAGE	E: 3.9Vdc I: 0.09A
ANTENNA TYPE	Fixed external antenna with -4.4dBi gain
DATA CABLE	1.3m non-shielded cable for earphone 1.1m non-shielded USB cable
I/O PORTS	Refer to user's manual
ASSOCIATED DEVICES	Earphone Brand: SAGEM Model: EM-SG644ST
EUT Extreme Vol. Range	3.3Vdc to 4.5Vdc

NOTE:

1. The EUT is a Dual Band GSM GPRS Mobile Phone. The protocol of this system is GSM850, and PCS1900.
2. IMEI Code: 01099800000345-2
3. Hardware version: V2.0
4. Software version:L23-9B
5. The above EUT information was declared by manufacturer and for more detailed features description, please refer to the manufacturer's specifications or User's Manual.

3.2 DESCRIPTION OF TEST MODES

124 channels are provided to this EUT in the GSM850 band. Therefore, the low, middle and high channels are chosen for testing.

	CHANNEL	FREQUENCY	TX MODE
LOW	128	824.2 MHz	GSM
MIDDLE	190	836.6 MHz	GSM
HIGH	251	848.8 MHz	GSM

NOTE:

1. Below 1 GHz, the channel 128, 190, and 251 were pre-tested in chamber. The channel 128 was chosen for final test.
2. Above 1 GHz, the channel 128, 190, and 251 were tested individually.
3. When the Power Control Level set 5, the worst case, was chosen for final test.
4. The channel space is 0.2MHz.
5. Since the EUT is considered a portable unit, it was pre-tested on the positioned of each 3 axis. The worst case was found when positioned on X-plane. Therefore only the test data of this X-plane was used for radiated emission measurement test.
6. For the radiated emission measurement test, GSM mode has been chosen for the worst and recorded in this test report after pre-testing both GSM and GPRS mode.
7. For the radiated emission measurement test below 1GHz, there are three test modes. Mode A is powered by battery, mode B is charged by power adapter, mode C is connected with PC.

3.3 GENERAL DESCRIPTION OF APPLIED STANDARDS

The EUT is a Dual Band GSM GPRS Mobile Phone. According to the specifications of the manufacturer, it must comply with the requirements of the following standards:

FCC 47 CFR Part 2

FCC 47 CFR Part 22

IC RSS-132

ANSI C63.4-2003

ANSI/TIA/EIA-603-A

NOTE: All test items have been performed and recorded as per the above standards.

3.4 DESCRIPTION OF SUPPORT UNITS

The EUT has been tested as an independent unit together with other necessary accessories or support units. The following support units or accessories were used to form a representative test configuration during the tests.

NO.	PRODUCT	BRAND	MODEL NO.	SERIAL NO.	CAL. DATE
1	Universal Radio Communication Tester	R&S	CMU200	109373	Nov. 20, 2006

NO.	SIGNAL CABLE DESCRIPTION OF THE ABOVE SUPPORT UNITS
A	N/A

4 TEST TYPES AND RESULTS

4.1 MODULATION CHARACTERISTICS

4.1.1 DESCRIPTION OF MODULATION TECHNIQUE

According to FCC 2.1047(d), the system is used the digital modulation and accomplished with the GSM requirement. It uses narrowband TDMA. Eight simultaneous calls can occupy the same radio frequency.

There are 124 channels and channel space is 200kHz. The frequency band 824.2 ~ 848.8MHz is allocated to the uplink and 869.2 ~ 893.8MHz to the downlink. The uplink and downlink channel space is 45MHz and is duplex at the same time.

4.1.2 THE ACTIVE TIME SLOT 8 MODULATED FRAME PLOT

FOR GSM MODE

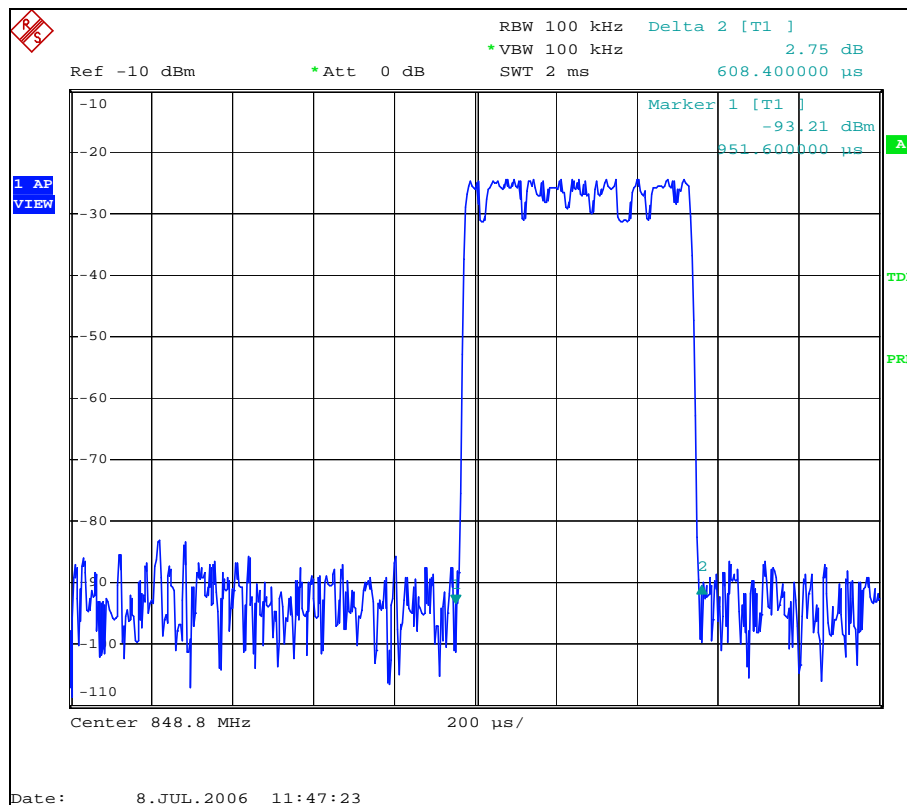
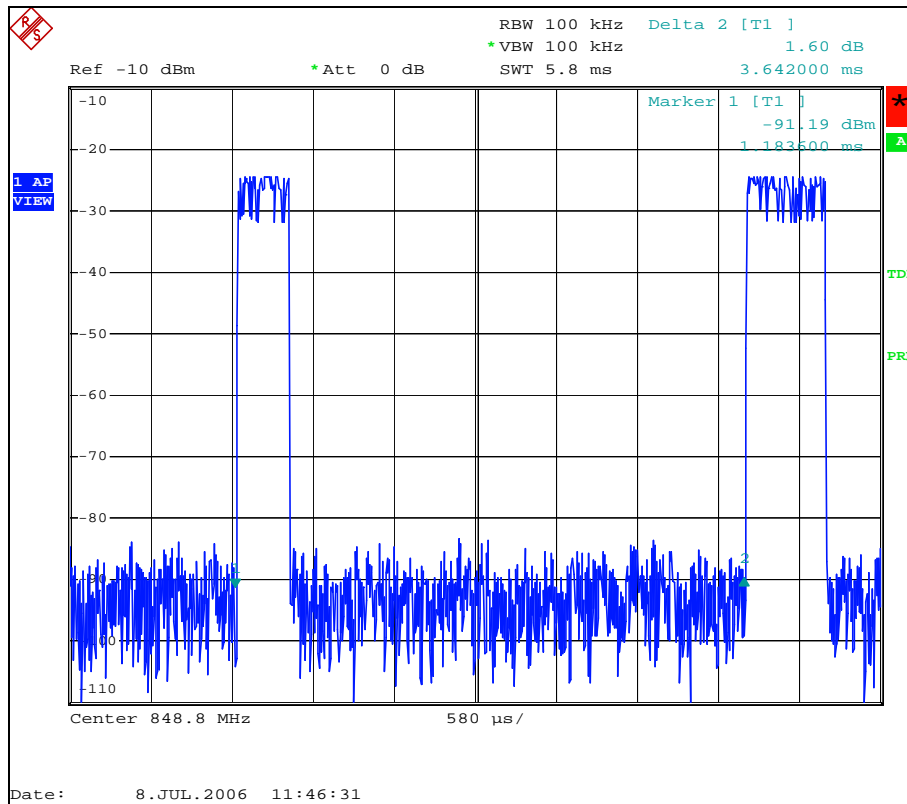



FOR GPRS MODE

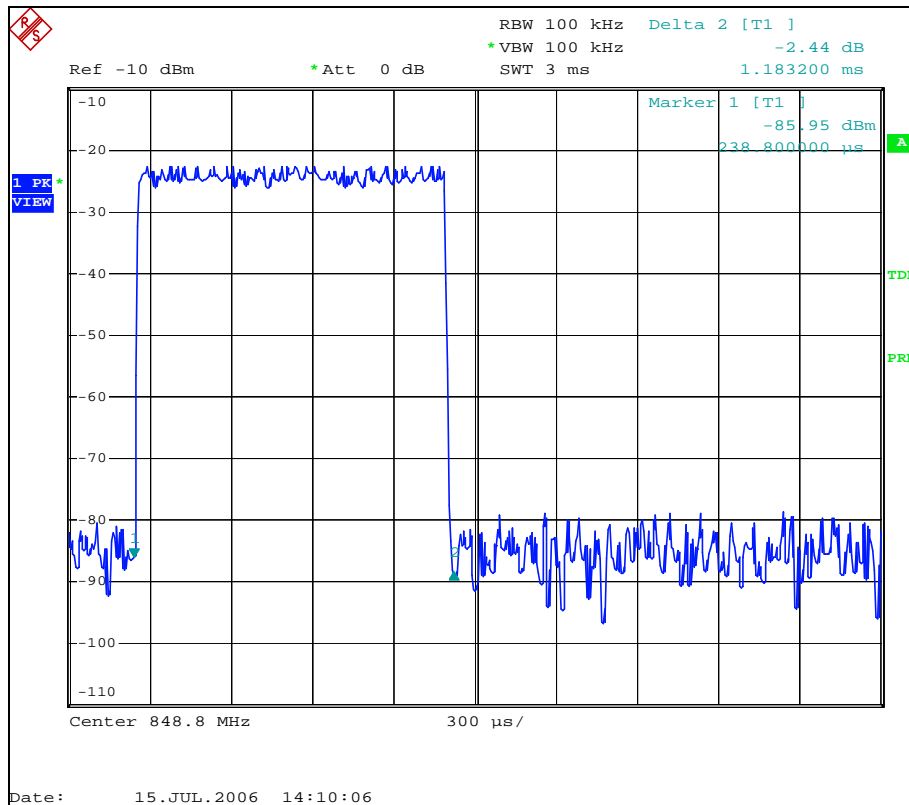
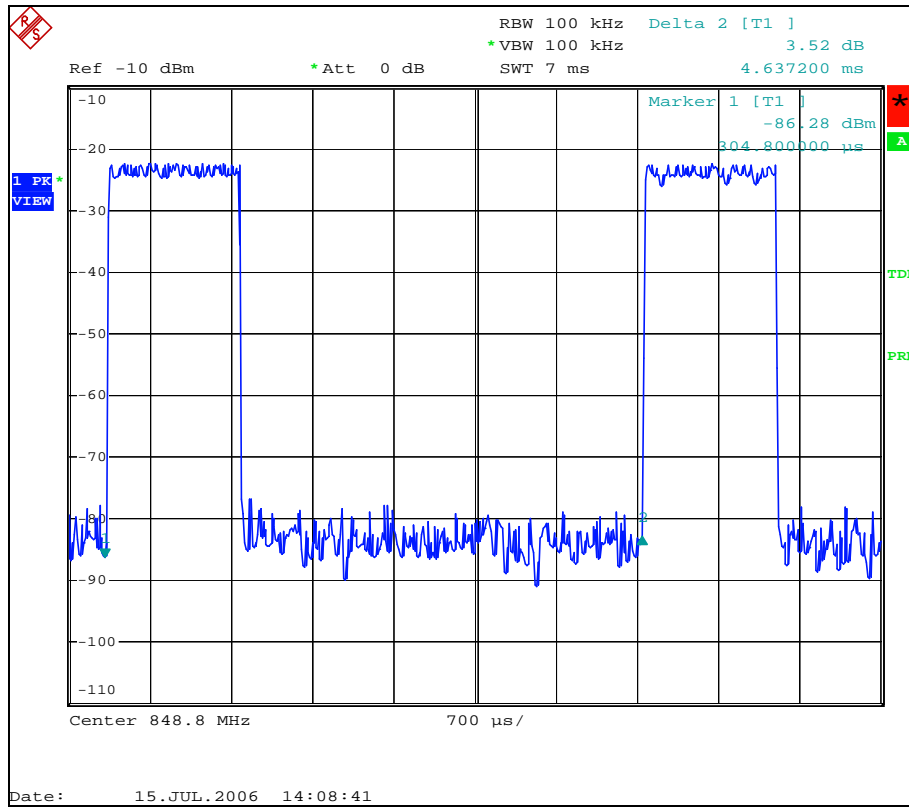

4.2 OUTPUT POWER MEASUREMENT

4.2.1 LIMITS OF OUTPUT POWER MEASUREMENT

The radiated peak output power shall be according to the specific rule Part 22.913 (a) that "Mobile / Portable station are limited to 7 watts e.r.p".

4.2.2 TEST INSTRUMENTS

DESCRIPTION & MANUFACTURER	MODEL NO.	SERIAL NO.	CALIBRATED UNTIL
Test Receiver ROHDE & SCHWARZ	ESCS30	E1R1001	Apr. 19, 2007
BILOG Antenna SCHWARZBECK	VULB9168	E1A1001	Sep. 26, 2006
Preamplifier Agilent	8447D	E1A2001	Jan. 27, 2007
Preamplifier Agilent	8449B	E1A2002	Jan. 27, 2007
Double Ridged Broadband Horn Antenna Schwarzbeck	BBHA 9120D	E1A1002	Feb.15, 2007
Spectrum Analyzer Agilent	E4403B	E1S1001	Jan. 13, 2007
Spectrum Analyzer ROHDE & SCHWARZ	FSP30	E1S1002	May.15, 2007
RF signal cable Woken	RG-402	E1CBH01	May. 30, 2007
RF signal cable Woken	RG-402	E1CBH02	May. 30, 2007
RF signal cable Woken	RG-402	E1CBH03	May. 30, 2007
RF signal cable Woken	RG-412	E1CBL02	May. 30, 2007
RF signal cable Woken	RG-412	E1CBL03	May. 30, 2007
RF signal cable Woken	RG-412	E1CBL04	May. 30, 2007
Software ADT	ADT_Radiated_V7.5	N/A	N/A
Power Splitter Mini-Circuits	ZAPD-4	400005	NA

- NOTE:**
1. The calibration interval of the above test instruments is 12 months.
 2. The horn antenna and Agilent preamplifier (model: 8449B) are used only for the measurement of emission frequency above 1GHz if tested.
 3. The Spectrum Analyzer (model: FSP30) and RF signal cable (SERIAL: E1CBH05&E1CBH07) are used only for the measurement of emission frequency above 1GHz if tested.

4.2.3 TEST PROCEDURES

- a. The EUT was set up for the maximum peak power with GSM link data modulation. The power was measured with R&S Spectrum Analyzer. All measurements were done at 3 channels, 128, 190 and 251 (low, middle and high operational frequency range.)
- b. The conducted peak output power used the power splitter via EUT RF power connector between simulation base station and spectrum analyzer. The path loss included the splitter loss, cable loss and 20dB pad loss. The spectrum set RB/VB 3MHz, then read peak power value and record to the test. (All transmitted path loss shall be considered in the test report data.)
- c. E.I.R.P peak power measurement. In the fully anechoic chamber, EUT placed on the 1.5m height of Turn Table, rotated the table around 360 degrees to search the maximum radiation power and receiver antenna shall be rotated vertical and horizontal polarization to find the maximum polar radiated power. The "Read Value" is the spectrum reading the maximum power value.
- d. The substitution horn antenna is substituted for EUT at the same position and signals generator export the CW signal to the calibration antenna. Rotated the Turn Table to find the maximum radiation power. "Raw" is the spectrum reading value, "SG" is signal generator export power, "TX Gain" is calibration antenna isotropic gain value, "TX cable" is the transmitted cable loss between the calibration antenna and signal generator. The "Factor" means that the transmission path loss is equal to "SG" - "TX cable" + "TX Gain" - "Raw".
- e. Actually the real E.I.R.P peak power is equal to "Read Value" + "Factor"
- f. E.R.P power can be calculated form E.I.R.P power by subtracting the gain of dipole, $E.R.P \text{ power} = E.I.P.R \text{ power} - 2.15\text{dBi}$.

NOTE: The resolution bandwidth and video bandwidth of test receiver/spectrum analyzer is 3MHz for Peak detection (PK)

4.2.4 TEST SETUP

EIRP POWER MEASUREMENT:

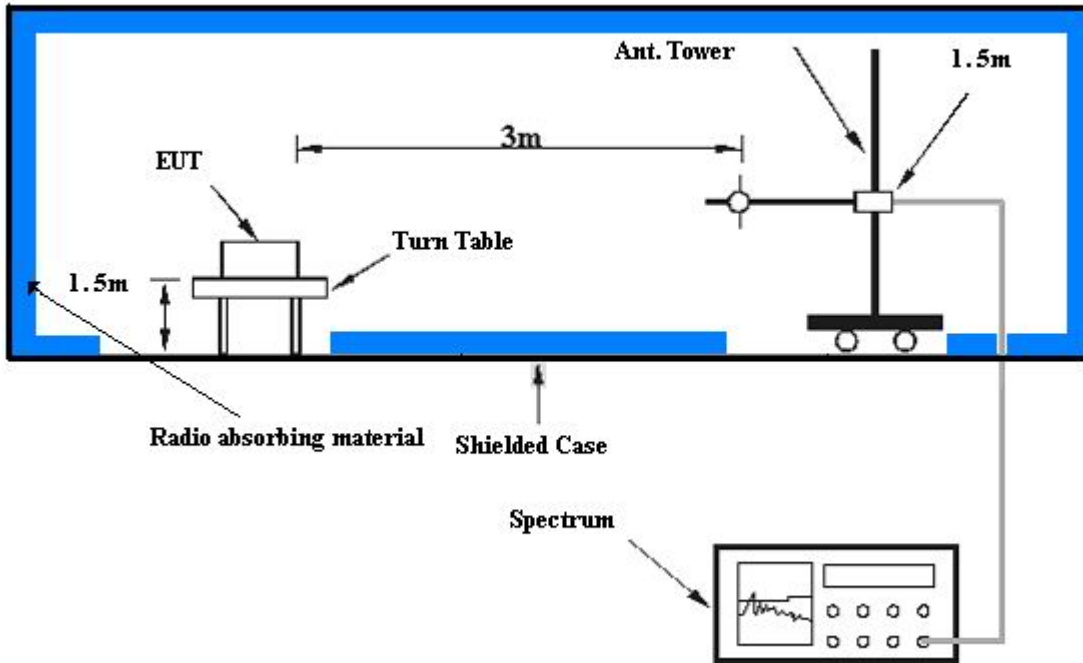

For the actual test configuration, please refer to the related item – Photographs of the Test Configuration.

CONDUCTED POWER MEASUREMENT:

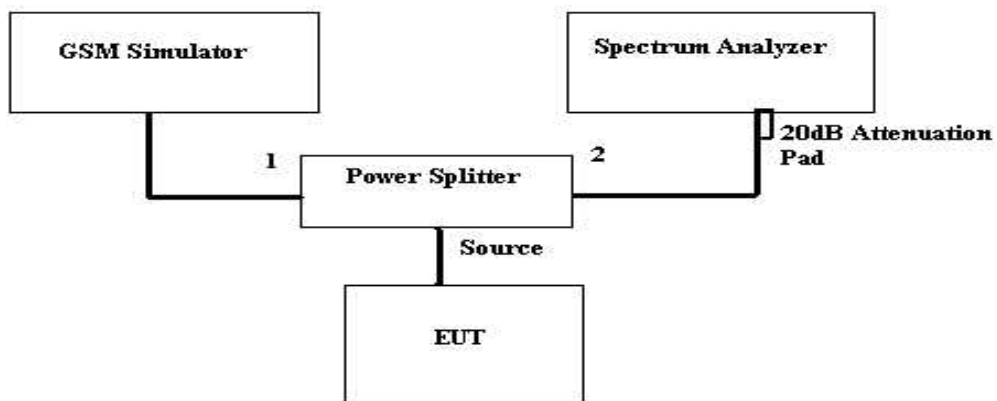

For the actual test configuration, please refer to the related item – Photographs of the Test Configuration.

4.2.5 EUT OPERATING CONDITIONS

- a. The EUT makes a phone call to the GSM simulator.
- b. The GSM simulator station system controlled a EUT to export maximum output power under transmission mode and specific channel frequency.

4.2.6 TEST RESULTS

EUT	Dual Band GSM GPRS Mobile Phone	MODEL	M19
MODE	TX connected	POWER CONTROL LEVEL	5
INPUT POWER (SYSTEM)	120Vac, 60Hz	DETECTOR FUNCTION	Peak
ENVIRONMENTAL CONDITIONS	27deg. C, 60%RH, 991hPa	TESTED BY	Bright

FOR GSM MODE

CONDUCTED PEAK OUTPUT POWER					
CHANNEL NO.	FREQUENCY (MHz)	RAW VALUE (dBm)	CORRECTION FACTOR (dB)	PEAK OUTPUT POWER	
				dBm	Watt
128	824.2	32.6	0.2	32.80	1.905
190	836.6	32.8	0.2	33.00	1.995
251	848.8	33.0	0.2	33.20	2.089

REMARKS: 1. Peak Output Power (dBm) = Raw Value (dBm) + Correction Factor (dB).

EUT	Dual Band GSM GPRS Mobile Phone	MODEL	M19
MODE	TX connected	POWER CONTROL LEVEL	5
INPUT POWER (SYSTEM)	120Vac, 60Hz	DETECTOR FUNCTION	Peak
ENVIRONMENTAL CONDITIONS	27deg. C, 60%RH, 991hPa	TESTED BY	Bright

FOR GSM MODE

RADIATED ERP PEAK OUTPUT POWER					
CHANNEL NO.	FREQUENCY (MHz)	RAW VALUE (dBm)	CORRECTION FACTOR (dB)	PEAK OUTPUT POWER	
				dBm	Watt
128	824.2	20.79	5.54	26.33	0.430
190	836.6	20.6	5.46	26.06	0.404
251	848.8	20.55	5.37	25.92	0.391

REMARKS: 1. Peak Output Power (dBm) = Raw Value (dBm) + Correction Factor (dB).

EUT	Dual Band GSM GPRS Mobile Phone	MODEL	M19
MODE	TX connected	POWER CONTROL LEVEL	4
INPUT POWER (SYSTEM)	120Vac, 60Hz	DETECTOR FUNCTION	Peak
ENVIRONMENTAL CONDITIONS	27deg. C, 60%RH, 991hPa	TESTED BY	Bright

FOR GPRS MODE

CONDUCTED PEAK OUTPUT POWER					
CHANNEL NO.	FREQUENCY (MHz)	RAW VALUE (dBm)	CORRECTION FACTOR (dB)	PEAK OUTPUT POWER	
				dBm	Watt
128	824.2	30.9	0.2	31.1	1.288
190	836.6	31.2	0.2	31.4	1.380
251	848.8	31.4	0.2	31.6	1.445

REMARKS: 1. Peak Output Power (dBm) = Raw Value (dBm) + Correction Factor (dB).

EUT	Dual Band GSM GPRS Mobile Phone	MODEL	M19
MODE	TX connected	POWER CONTROL LEVEL	4
INPUT POWER (SYSTEM)	120Vac, 60Hz	DETECTOR FUNCTION	Peak
ENVIRONMENTAL CONDITIONS	27deg. C, 60%RH, 991hPa	TESTED BY	Bright

FOR GPRS MODE

RADIATED ERP PEAK OUTPUT POWER					
CHANNEL NO.	FREQUENCY (MHz)	RAW VALUE (dBm)	CORRECTION FACTOR (dB)	PEAK OUTPUT POWER	
				dBm	Watt
128	824.2	20.34	5.54	23.73	0.236
190	836.6	20.97	5.46	24.28	0.268
251	848.8	20.54	5.37	23.76	0.238

REMARKS: 1. Peak Output Power (dBm) = Raw Value (dBm) + Correction Factor (dB).



4.3 FREQUENCY STABILITY MEASUREMENT

4.3.1 LIMITS OF FREQUENCY STABILITY MEASUREMENT

According to the FCC part 2.4235 shall be tested the frequency stability. The rule is defined that” The frequency stability shall be sufficient to ensure that the fundamental emission stays within the authorized frequency block.” The frequency error rate is according to the JTC standard that the frequency error rate shall be accurate to within 2.5ppm of the received frequency from the base station. The test extreme voltage is according to the 2.1055(d)(1) Vary primary supply voltage from 85 to 115 percent of the nominal value for other than hand carried battery equipment and the extreme temperature rule is comply with the 2.1055(a)(1) -30°C~50°C.

4.3.2 TEST INSTRUMENTS

DESCRIPTION & MANUFACTURER	MODEL NO.	SERIAL NO.	CALIBRATED UNTIL
UNIVERSAL RADIO COMMUNICATION TESTER	CMU 200	109373	Nov. 20, 2006

NOTE: The calibration interval of the above test instruments is 12 months. And the calibrations are traceable to NML/ROC and NIST/USA.

4.3.3 TEST PROCEDURE

- a. Because of the measure the carrier frequency under the condition of the AFC lock, it shall be used the mobile station in the GSM link mode. This is accomplished with the use of the R&S CMU200 simulator station. The oven room could control the temperatures and humidity. The GSM link channel is the 128.
- b. Power must be removed when changing from one temperature to another or one voltage to another voltage. Power warm up is at least 15 min and power applied should perform before recording frequency error.
- c. EUT is connected the external power supply to control the DC input power. The various Volts from the minimum 3.3 Volts to 4.5 Volts. Each step shall be record the frequency error rate.
- d. The temperature range step is 10 degrees in this test items. All temperature levels shall be hold the $\pm 0.5^{\circ}\text{C}$ during the measurement testing.
- e. The each temperature step shall be at least 0.5 hours, consider the EUT could be test under the stability condition.

NOTE: The frequency error was recorded frequency error from the GSM simulator.

4.3.4 TEST SETUP

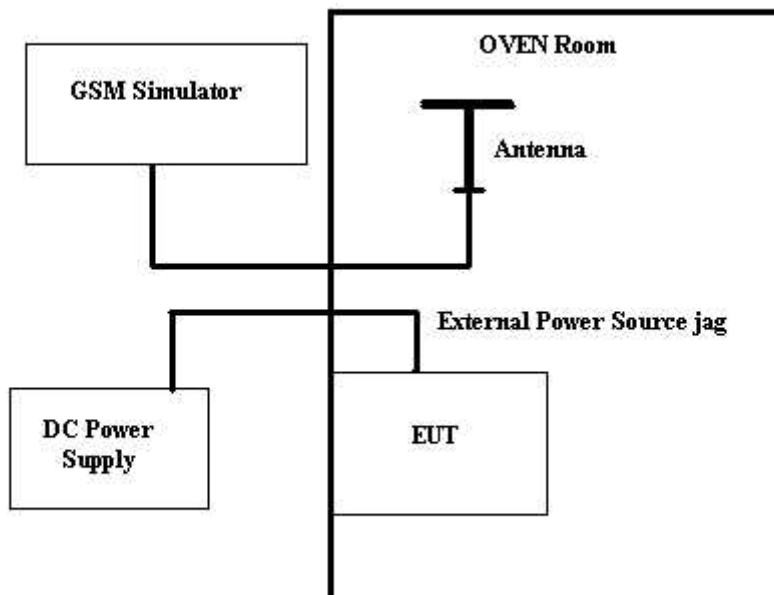

4.3.5 TEST RESULTS

EUT	Dual Band GSM GPRS Mobile Phone	MODEL	M19
MODE	TX channel 128	POWER CONTROL LEVEL	5
INPUT POWER (SYSTEM)	120Vac, 60Hz	ENVIRONMENTAL CONDITIONS	27deg. C, 60%RH, 991hPa
TESTED BY	Bright		

FOR GSM MODE

AFC FREQUENCY ERROR vs. VOLTAGE			
VOLTAGE (Volts)	FREQUENCY ERROR (Hz)	FREQUENCY ERROR (ppm)	LIMIT (ppm)
3.3	31	0.037612	2.5
3.4	44	0.053385	2.5
3.5	28	0.033972	2.5
3.6	16	0.019413	2.5
3.7	12	0.01456	2.5
3.8	23	0.027906	2.5
3.9	31	0.037612	2.5
4	32	0.038826	2.5
4.1	30	0.036399	2.5
4.2	45	0.054598	2.5
4.3	21	0.025479	2.5
4.4	26	0.031546	2.5
4.5	13	0.015773	2.5

EUT	Dual Band GSM GPRS Mobile Phone	MODEL	M19
MODE	TX channel 128	POWER CONTROL LEVEL	4
INPUT POWER (SYSTEM)	120Vac, 60Hz	ENVIRONMENTAL CONDITIONS	27deg. C, 60%RH, 991hPa
TESTED BY	Bright		

FOR GPRS MODE

AFC FREQUENCY ERROR vs. VOLTAGE			
VOLTAGE (Volts)	FREQUENCY ERROR (Hz)	FREQUENCY ERROR (ppm)	LIMIT (ppm)
3.3	25	0.030332	2.5
3.4	36	0.043679	2.5
3.5	36	0.043679	2.5
3.6	21	0.025479	2.5
3.7	18	0.021839	2.5
3.8	24	0.029119	2.5
3.9	35	0.042465	2.5
4	26	0.031546	2.5
4.1	21	0.025479	2.5
4.2	35	0.042465	2.5
4.3	24	0.029119	2.5
4.4	33	0.040039	2.5
4.5	27	0.032759	2.5

EUT	Dual Band GSM GPRS Mobile Phone	MODEL	M19
MODE	TX channel 128	POWER CONTROL LEVEL	5
INPUT POWER (SYSTEM)	120Vac, 60Hz	ENVIRONMENTAL CONDITIONS	27deg. C, 60%RH, 991hPa
TESTED BY	Bright		

FOR GSM MODE

AFC FREQUENCY ERROR vs. TEMPERATURE			
Temp. (°C)	Frequency Error (Hz)	Frequency Error (ppm)	Limit (ppm)
50	-13	-0.01532	2.5
40	12	0.01414	2.5
30	12	0.01414	2.5
20	21	0.02474	2.5
10	11	0.01296	2.5
0	14	0.01649	2.5
-10	20	0.02356	2.5
-20	17	0.02003	2.5
-30	17	0.02003	2.5

EUT	Dual Band GSM GPRS Mobile Phone	MODEL	M19
MODE	TX channel 128	POWER CONTROL LEVEL	5
INPUT POWER (SYSTEM)	120Vac, 60Hz	ENVIRONMENTAL CONDITIONS	27deg. C, 60%RH, 991hPa
TESTED BY	Bright		

FOR GPRS MODE

AFC FREQUENCY ERROR vs. TEMPERATURE			
Temp. (°C)	Frequency Error (Hz)	Frequency Error (ppm)	Limit (ppm)
50	-15	-0.01820	2.5
40	17	0.02063	2.5
30	16	0.01941	2.5
20	24	0.02912	2.5
10	15	0.01820	2.5
0	21	0.02548	2.5
-10	18	0.02184	2.5
-20	12	0.01456	2.5
-30	11	0.01335	2.5

4.4 OCCUPIED BANDWIDTH MEASUREMENT

4.4.1 LIMITS OF OCCUPIED BANDWIDTH MEASUREMENT

According to FCC 2.1049 (h) specified that emission bandwidth is defined as the width of the signal between two points, one below the carrier center frequency and one above the carrier center frequency, outside of which all emissions are attenuated at least 26 dB below the transmitter power.

4.4.2 TEST INSTRUMENTS

DESCRIPTION & MANUFACTURER	MODEL NO.	SERIAL NO.	CALIBRATED UNTIL
ROHDE & SCHWARZ Spectrum Analyzer	FSP30	E1S1002	May. 16, 2007
UNIVERSAL RADIO COMMUNICATION TESTER	CMU 200	109373	Nov. 20, 2006
Power Splitter *Mini-Circuits	ZX10-2-20	E2PS001	NA

NOTE: 1. The calibration interval of the above test instruments is 12 months. And the calibrations are traceable to NML/ROC and NIST/USA.

4.4.3 TEST SETUP

Same as Item 4.2.4 (Conducted Power Setup)

4.4.4 TEST PROCEDURES

- a. The EUT was set up for the maximum peak power with GSM link data modulation. The power was measured with R&S Spectrum Analyzer. All measurements were done at 3 channels, 128, 190 and 251 (low, middle and high operational frequency range.)
- b. The conducted occupied bandwidth used the power splitter via EUT RF power connector between simulation base station and spectrum analyzer.
- c. FCC 2.1049 (h) required a measurement bandwidth is the fundamental emission below 26dB bandwidth.

4.4.5 EUT OPERATING CONDITION

- a. The EUT makes a phone call to the GSM simulator.
- b. The GSM simulator station system controlled a EUT to export maximum output power under transmission mode and specific channel frequency.

4.4.6 TEST RESULTS

FOR GSM MODE

CHANNEL	FREQUENCY (MHz)	MAX. OUTPUT POWER -26 dBc BANDWIDTH (kHz)
128	824.2	284
190	836.6	280
251	848.8	260

CH128

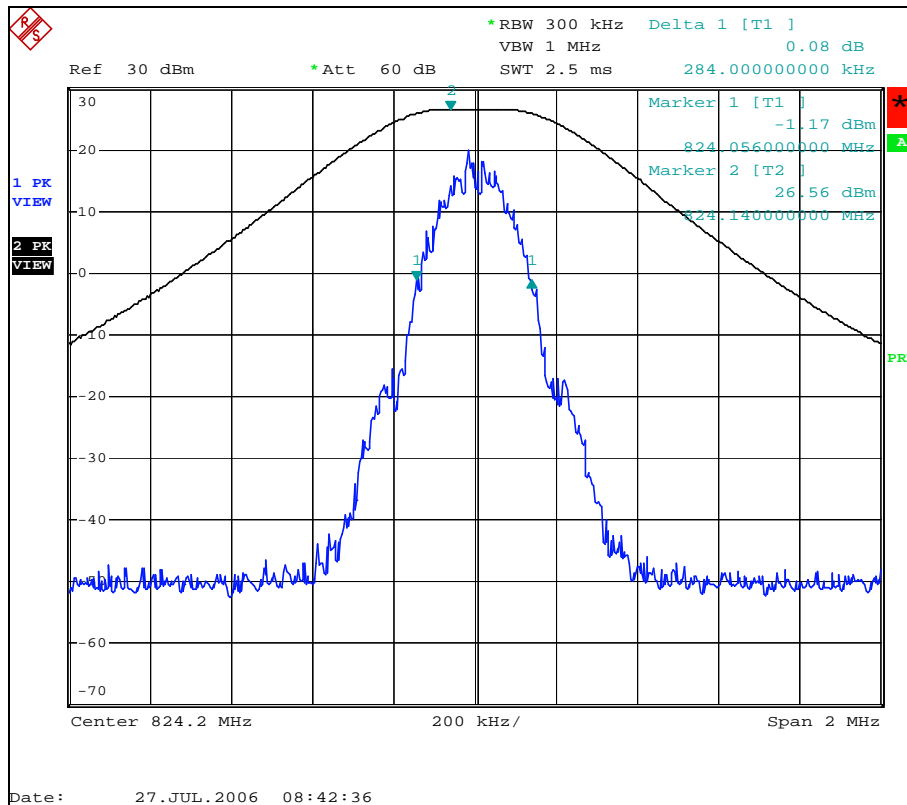

CH190

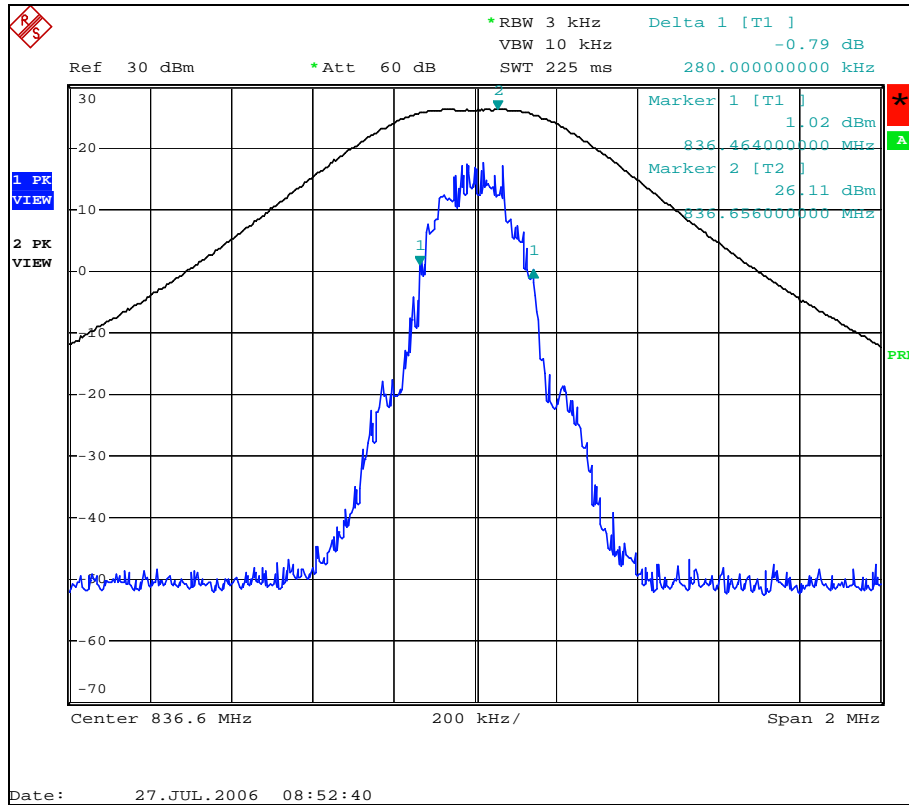

CH251

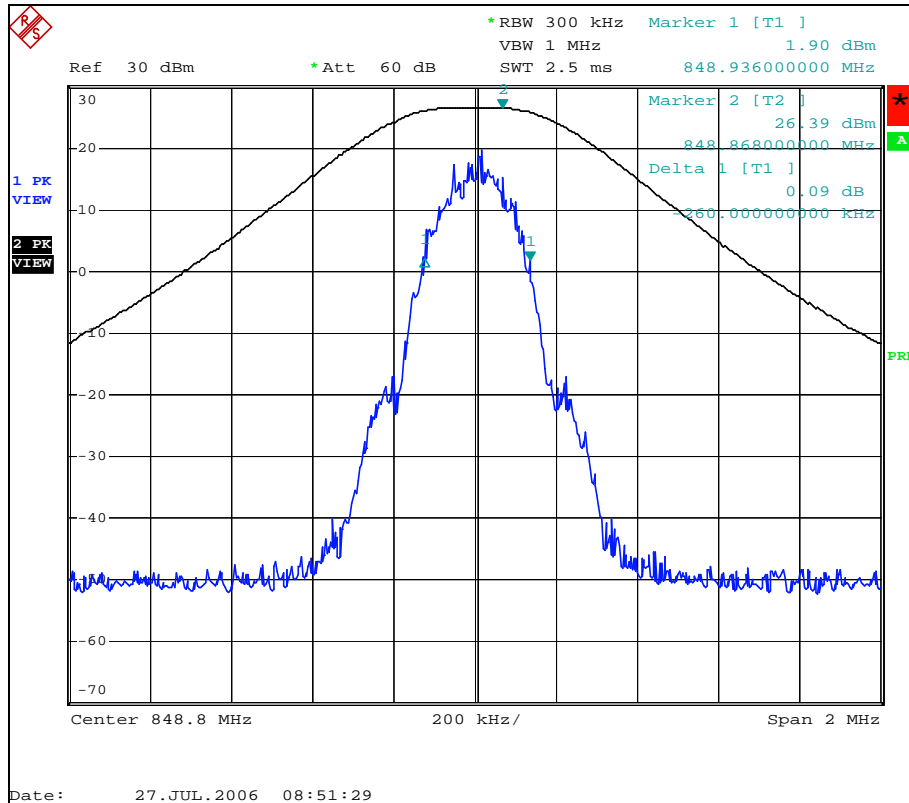



FOR GPRS MODE

CHANNEL	FREQUENCY (MHz)	MAX. OUTPUT POWER -26 dBc BANDWIDTH (kHz)
128	824.2	280
190	836.6	260
251	848.8	268

CH128

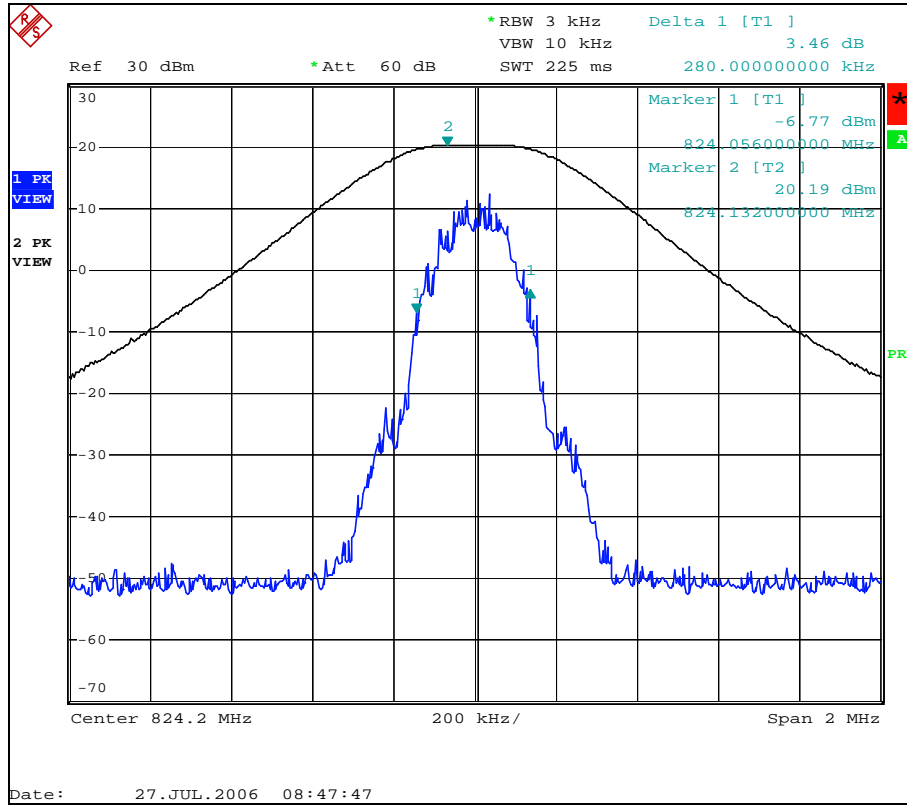

CH190

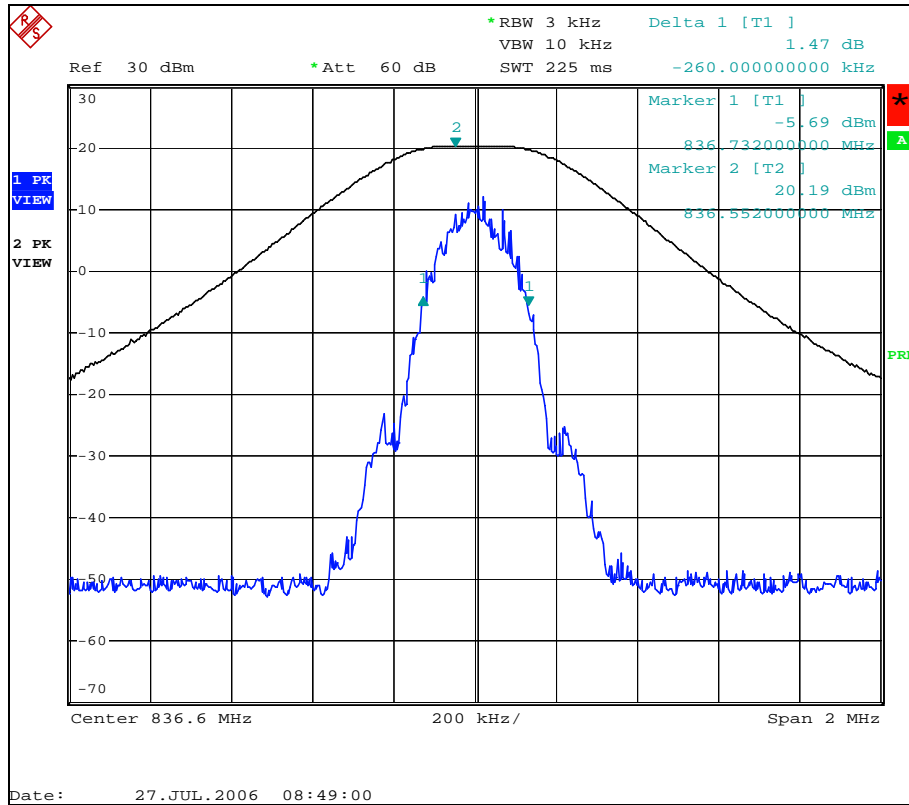

CH251

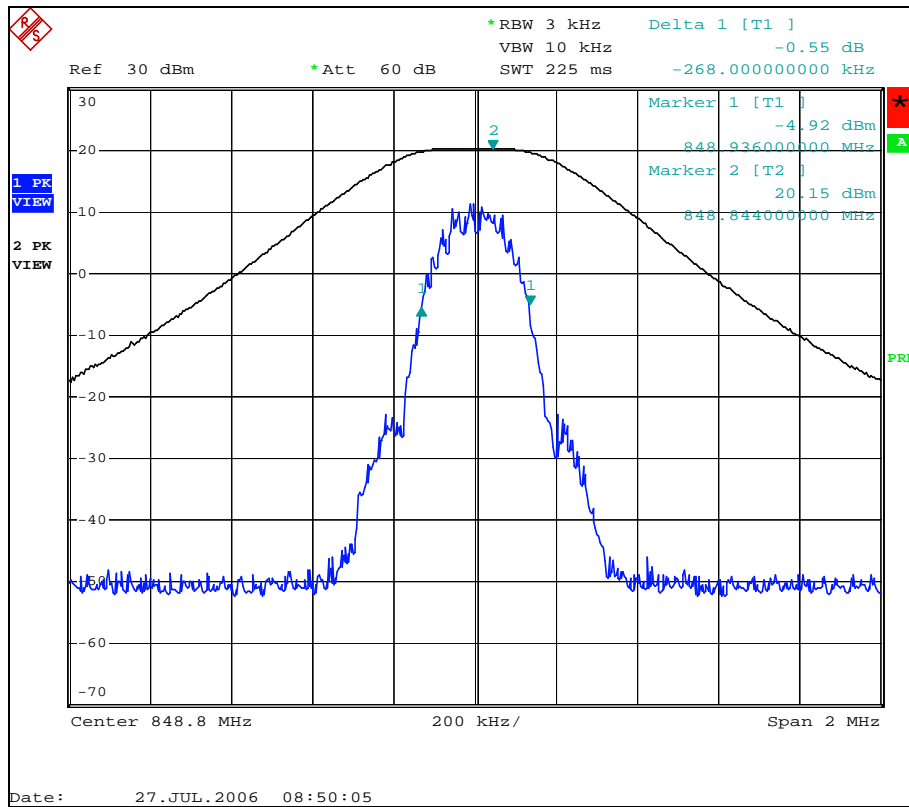

4.5 BAND EDGE MEASUREMENT

4.5.1 LIMITS OF BAND EDGE MEASUREMENT

According to FCC 22.917 specified that power of any emission outside of the authorized operating frequency ranges must be attenuated below the transmitting power (P) by a factor of at least $43 + 10 \log (P)$ dB. In the 1 MHz bands immediately outside and adjacent to the frequency block a resolution bandwidth of at least one percent of the emission bandwidth of the fundamental emission of the transmitter may be employed. Then we measure that the resolution bandwidth is 3 kHz.

4.5.2 TEST INSTRUMENTS

DESCRIPTION & MANUFACTURER	MODEL NO.	SERIAL NO.	CALIBRATED UNTIL
ROHDE & SCHWARZ Spectrum Analyzer	FSP30	E1S1002	May. 16, 2007
UNIVERSAL RADIO COMMUNICATION TESTER	CMU200	109373	Nov. 20, 2006
Power Splitter Mini-Circuits	ZX10-2-20	E2PS001	NA

NOTE: 1. The calibration interval of the above test instruments is 12 months. And the calibrations are traceable to NML/ROC and NIST/USA.

4.5.3 TEST SETUP

Same as Item 4.2.4 (Conducted Power Setup)

4.5.4 TEST PROCEDURES

- a. The EUT was set up for the maximum peak power with GSM link data modulation. The power was measured with R&S Spectrum Analyzer. All measurements were done at 2 channels, 128 and 251 (low and high operational frequency range.)
- b. The band edge measurement used the power splitter via EUT RF power connector between simulation base station and spectrum analyzer.
- c. The center frequency of spectrum is the band edge frequency and span is 2 MHz. RB of the spectrum is 3kHz and VB of the spectrum is 10 KHz.
- d. Record the max trace plot into the test report.

4.5.5 EUT OPERATING CONDITION

- a. The EUT makes a phone call to the GSM simulator.
- b. The GSM simulator station system controlled a EUT to export maximum output power under transmission mode and specific channel frequency.

4.5.6 TEST RESULTS

For GSM Mode
Lower Band Edge

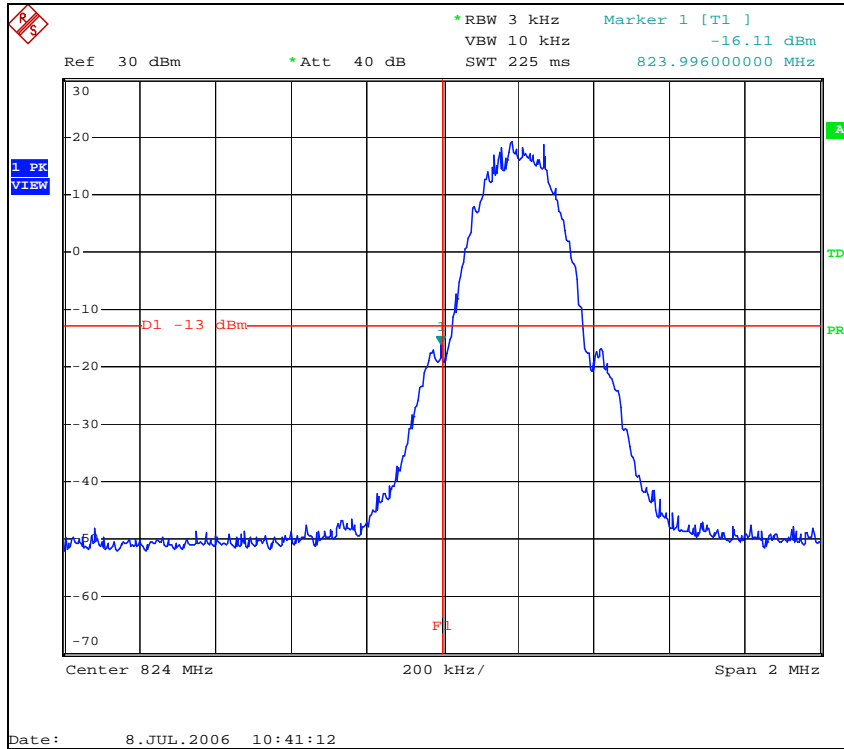

Higher Band Edge

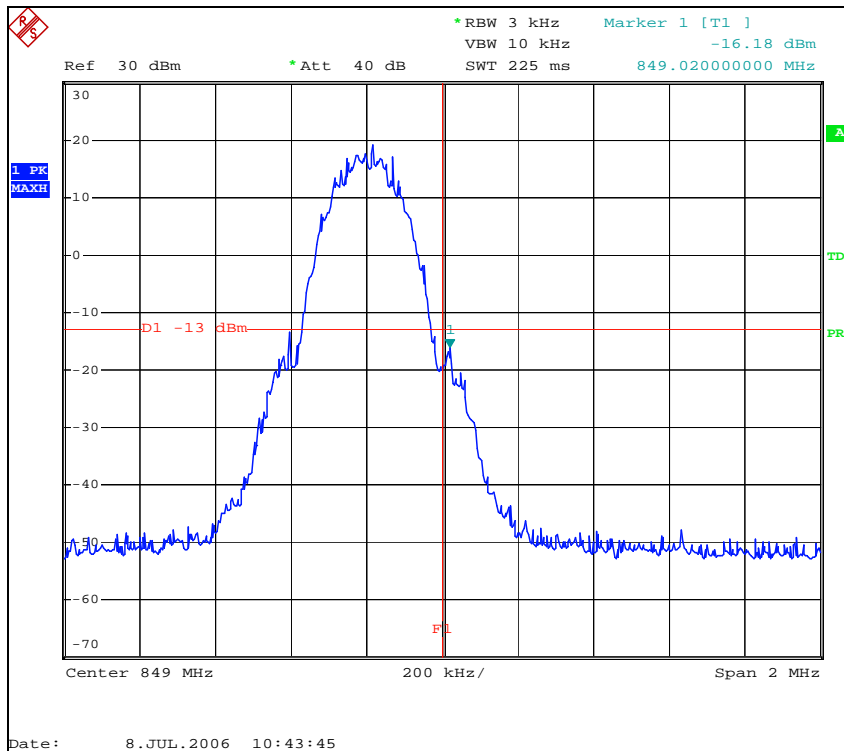

FOR GPRS MODE Lower Band Edge

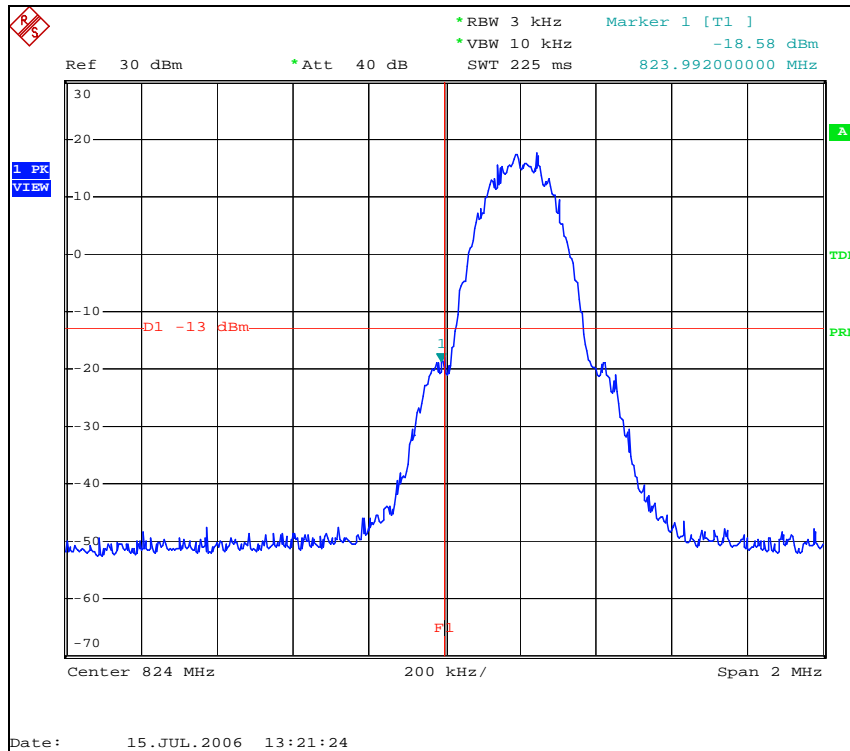

HIGHER Band Edge

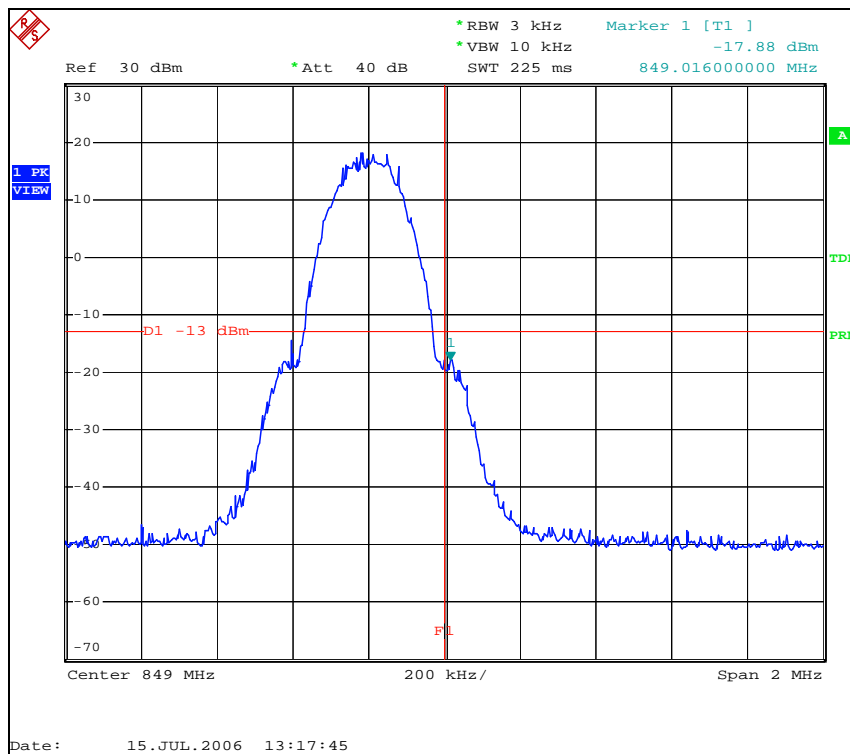

4.6 CONDUCTED SPURIOUS EMISSIONS

4.6.1 LIMITS OF CONDUCTED SPURIOUS EMISSIONS MEASUREMENT

In the FCC 22.917, on any frequency outside a licensee's frequency block within GSM spectrum, the power of any emission shall be attenuated below the transmitter power (P) by at least $43 + 10 \log (P)$ dB. The limit translates in the relevant power range (2 to 0.003W). At 2W (Power Control Level 3) the specified minimum attenuation becomes 43dB and the limit of emission equal to -13dBm .

4.6.2 TEST INSTRUMENTS

DESCRIPTION & MANUFACTURER	MODEL NO.	SERIAL NO.	CALIBRATED UNTIL
ROHDE & SCHWARZ Spectrum Analyzer	FSP30	E1S1002	May. 16, 2007
Universal Radio Communication Tester	CMU200	109373	Nov. 20, 2006
K & L Turnable Band Reject Filter	3TNF-00083	E1F4003	N/A
Wainwright Instruments High Pass Filter	WHK1.5/15G- 10ST	E1F4001	N/A

NOTE: 1. The calibration interval of the above test instruments is 12 months. And the calibrations are traceable to NML/ROC and NIST/USA.

4.6.3 TEST PROCEDURE

- a. The EUT was set up for the maximum peak power with GSM link data modulation. The power was measured with R&S Spectrum Analyzer. All measurements were done at 3 channels, 128, 190 and 251 (low, middle and high operational frequency range.)
- b. The conducted spurious emission used the power splitter via EUT RF power connector between simulation base station and spectrum analyzer.
- c. When the spectrum scanned from 9 kHz to 3GHz, it shall be connected to the band reject filter attenuated the carried frequency. The spectrum set RB/VB 1MHz.
- d. When the spectrum scanned from 3 kHz to 9GHz, it shall be connected to the high pass filter attenuated the carried frequency. The spectrum set RB/VB 1MHz.

4.6.4 TEST SETUP

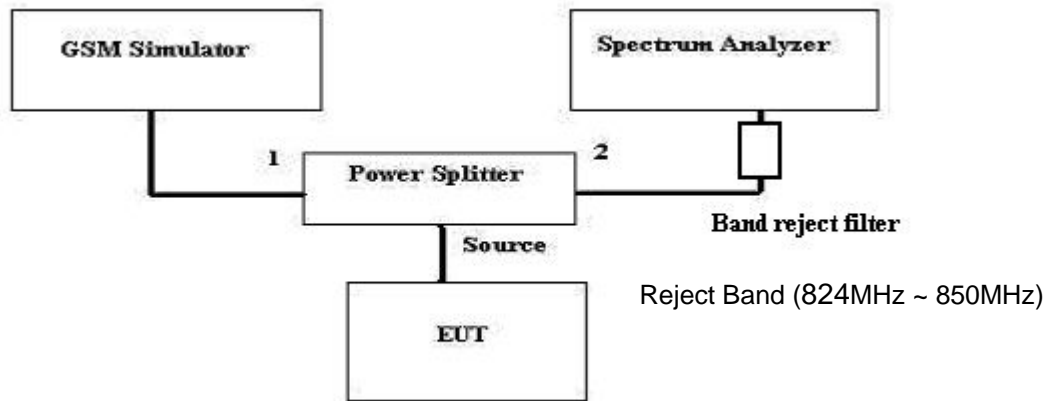

4.6.5 EUT OPERATING CONDITIONS

- a. The EUT makes a phone call to the GSM simulator.
- b. The GSM simulator station system controlled a EUT to export maximum output power under transmission mode and specific channel frequency.

4.6.6 TEST RESULTS

FOR GSM MODE

CH 128: 9kHz ~ 1GHz

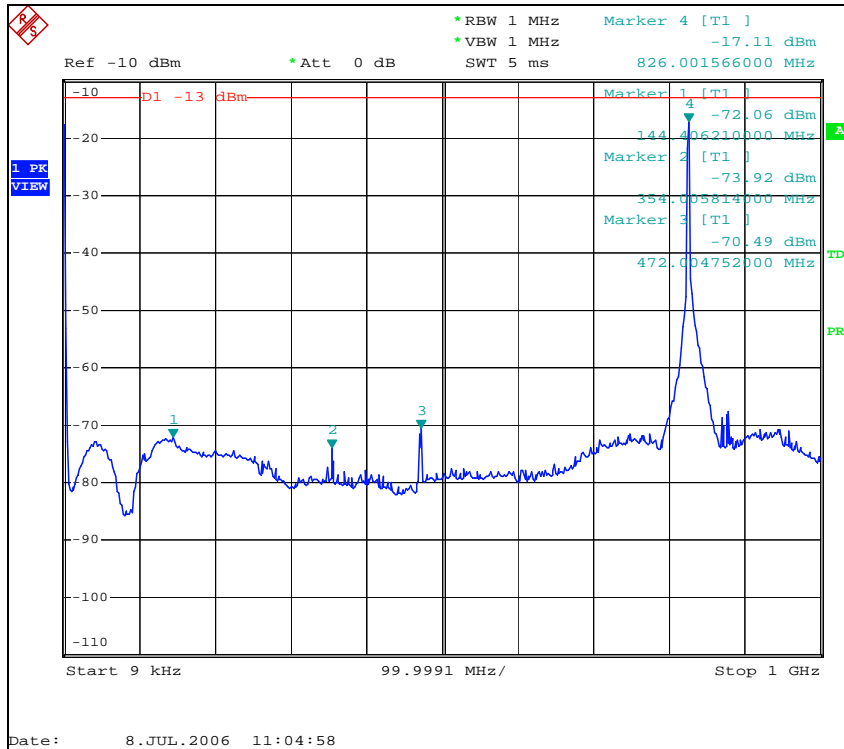

1GHz ~ 4GHz

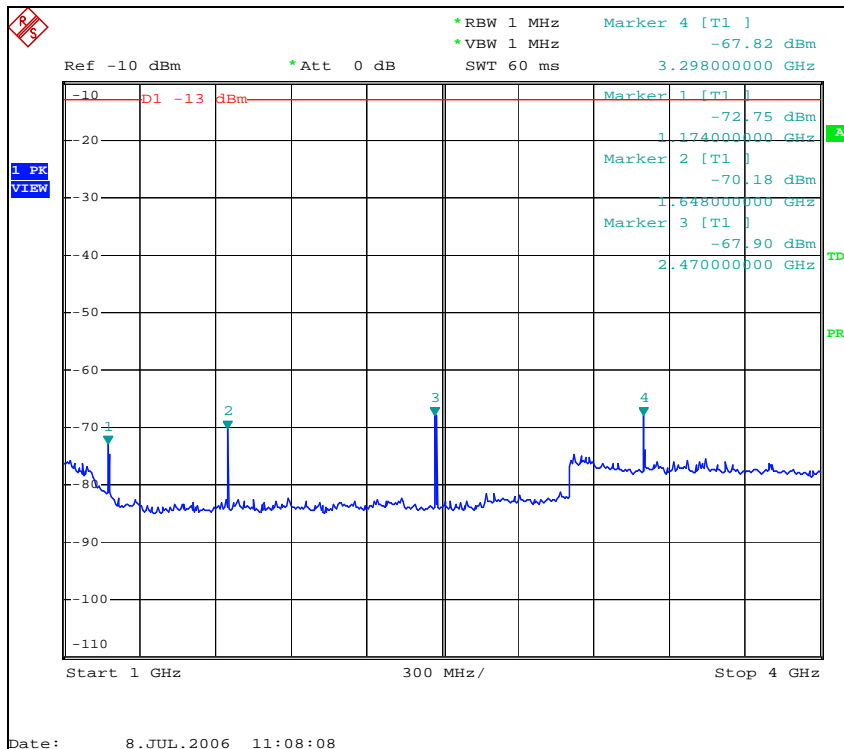



4GHz ~ 7GHz

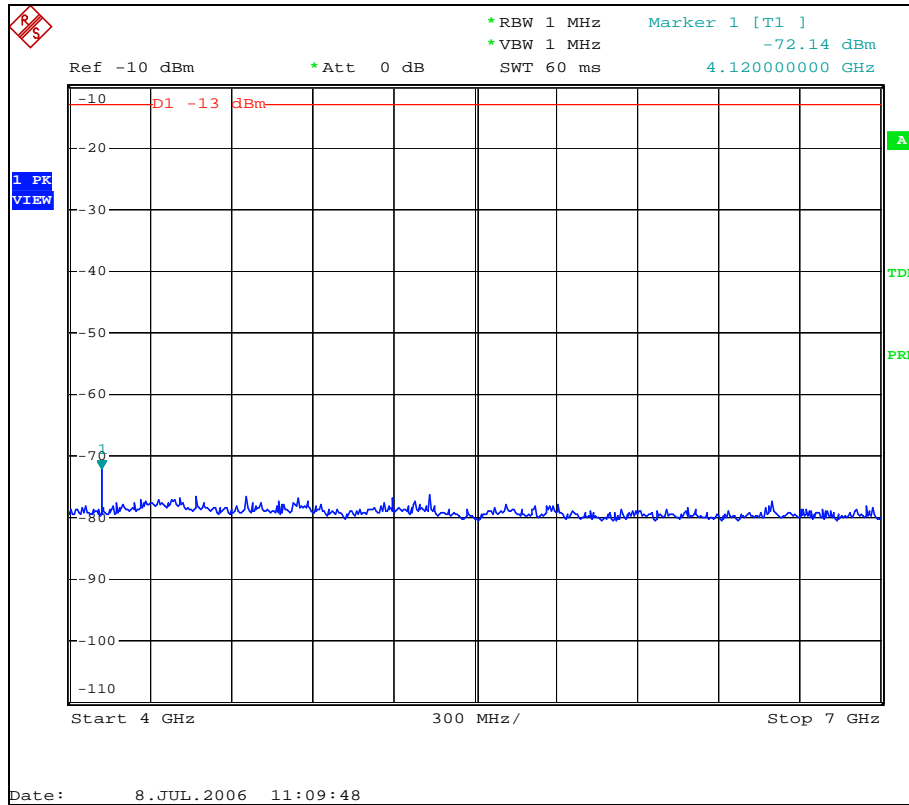

7GHz ~ 9GHz

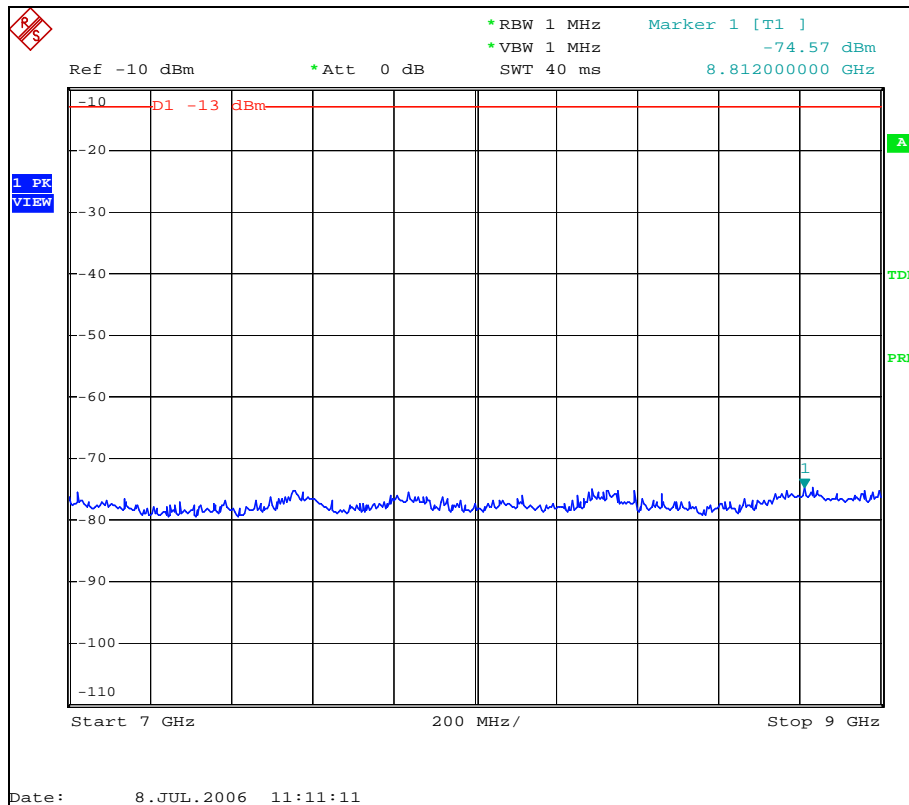

CH 190: 9kHz ~ 1GHz

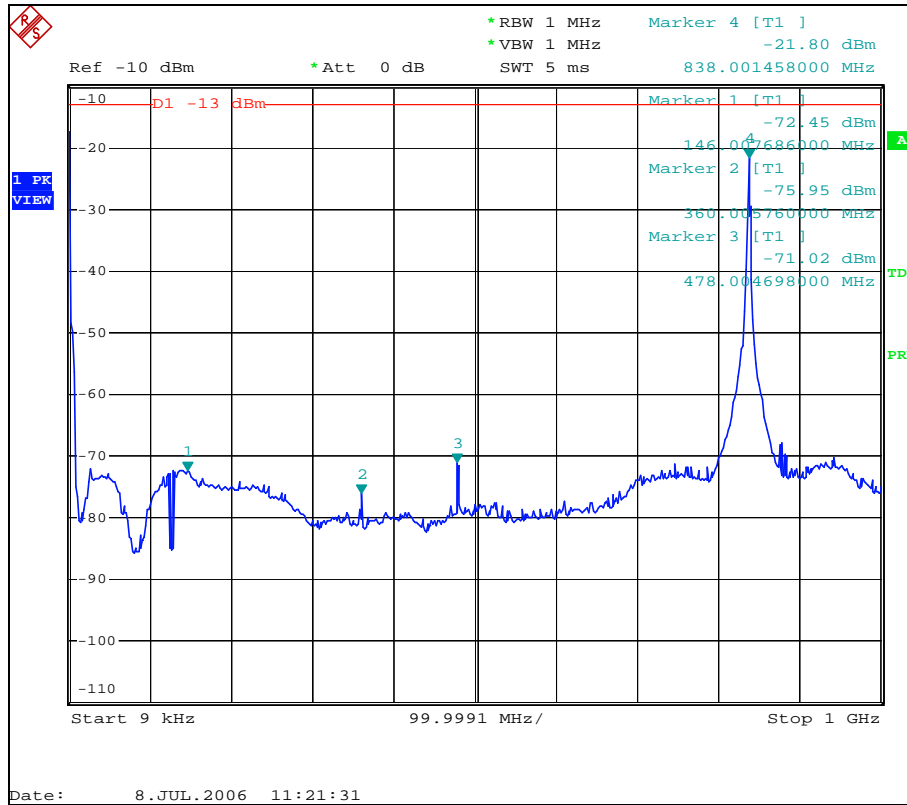

1GHz ~ 4GHz

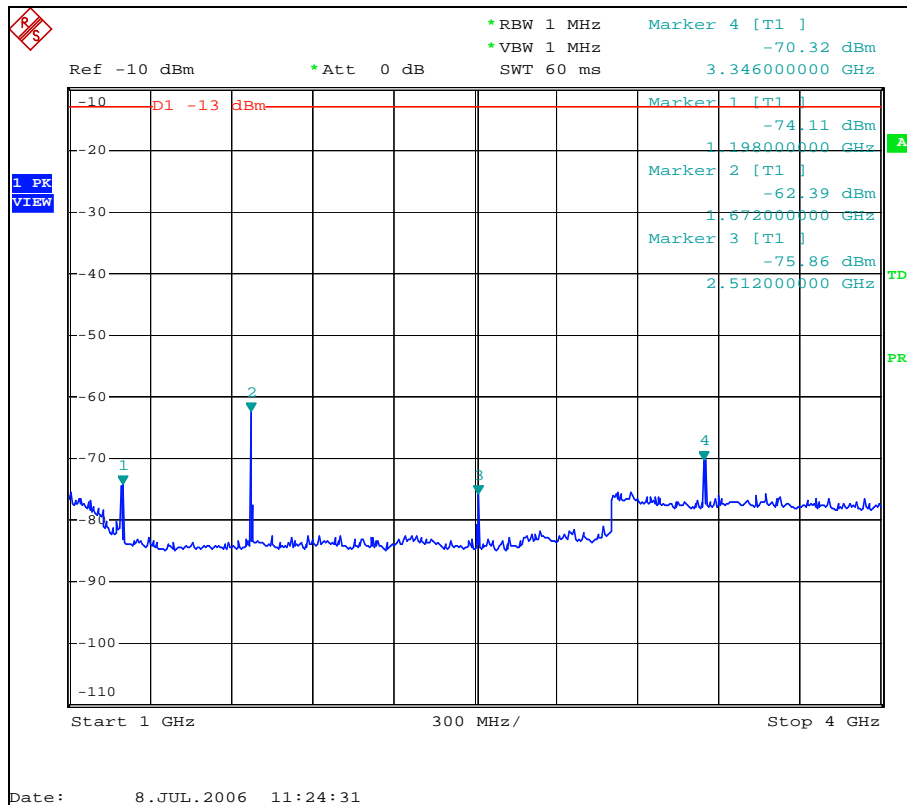



4GHz ~ 7GHz

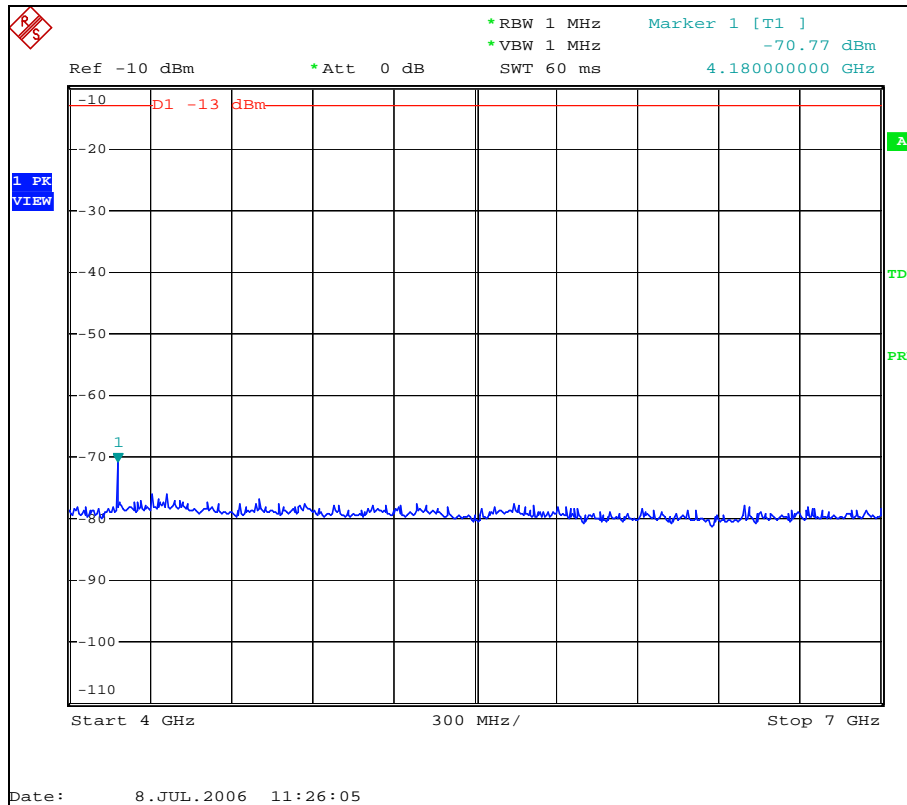

7GHz ~ 9GHz

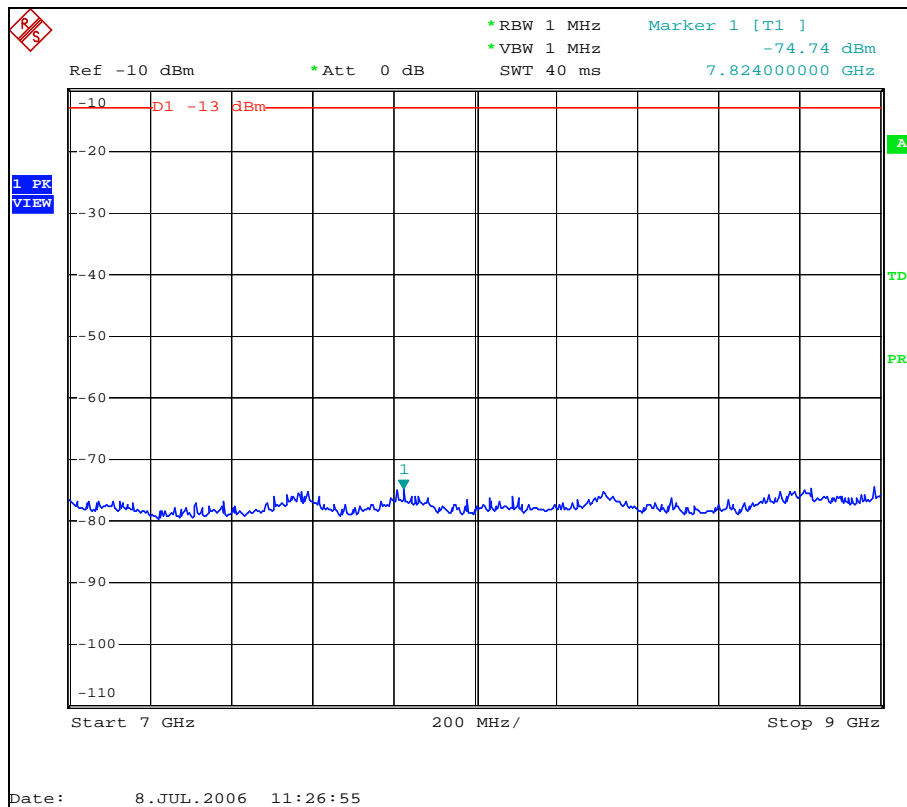

CH 251: 9kHz ~ 1GHz

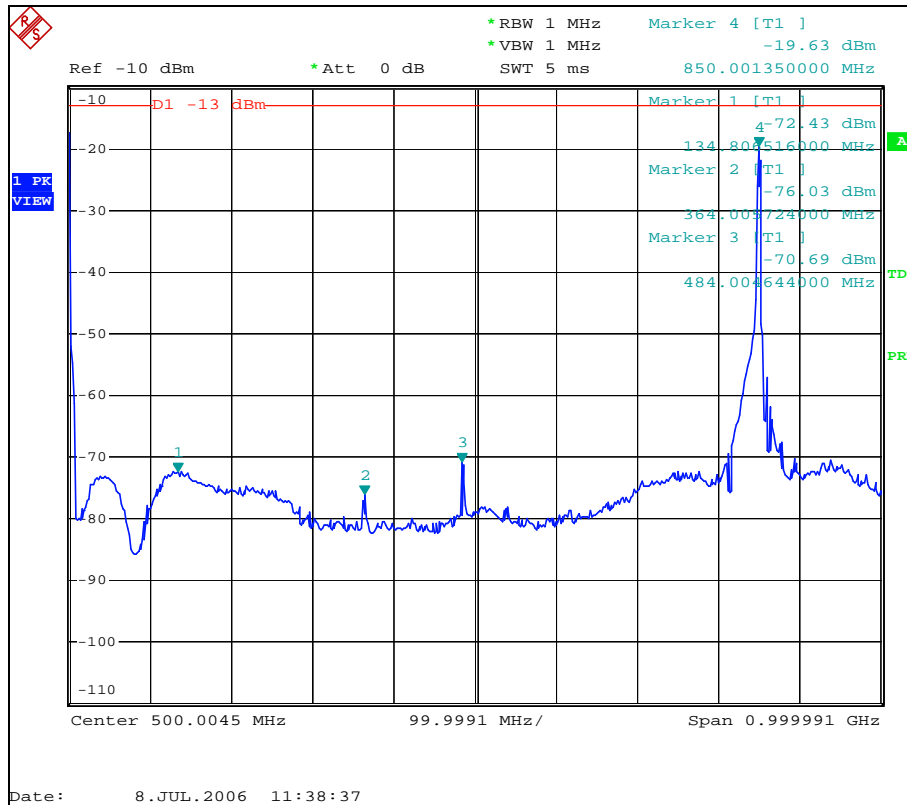

1GHz ~ 4GHz

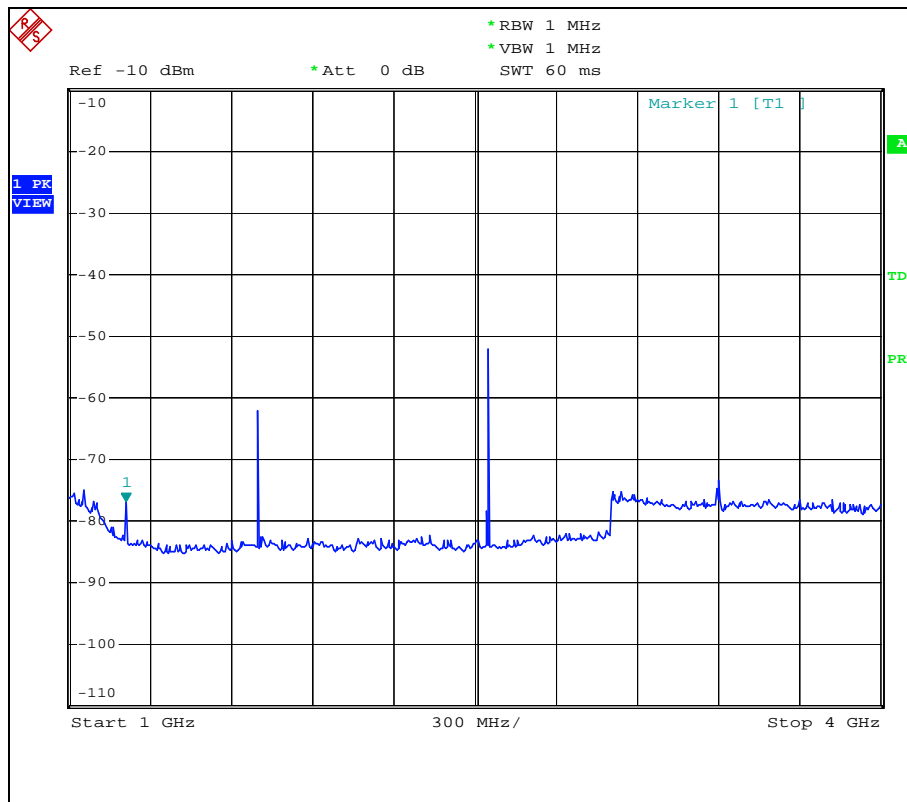



4GHz ~ 7GHz

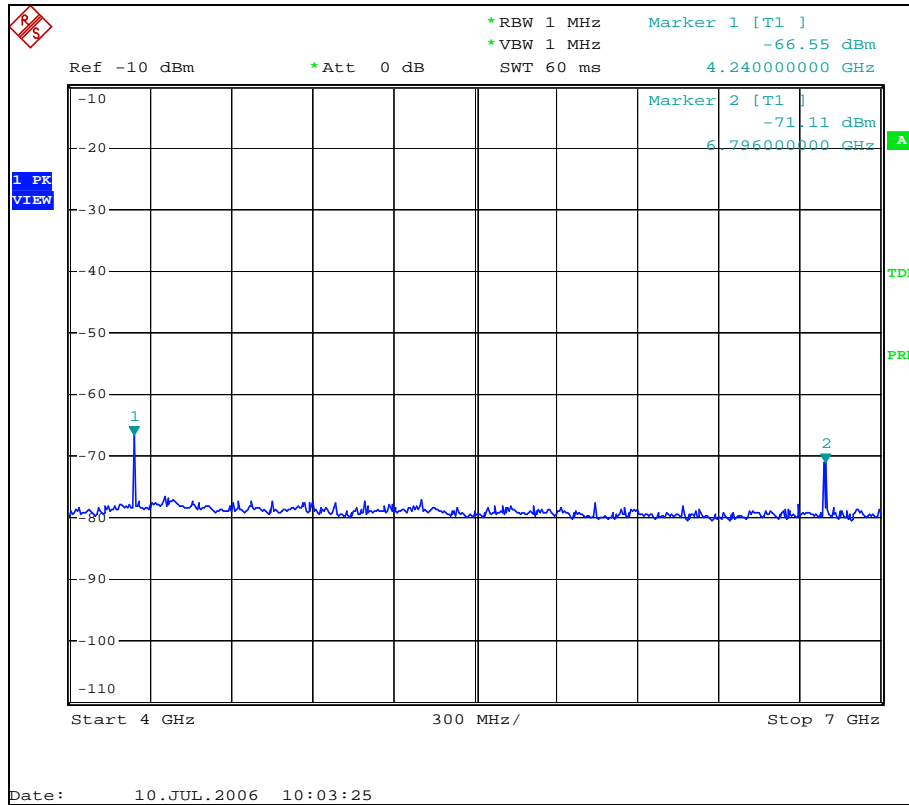

7GHz ~ 9GHz

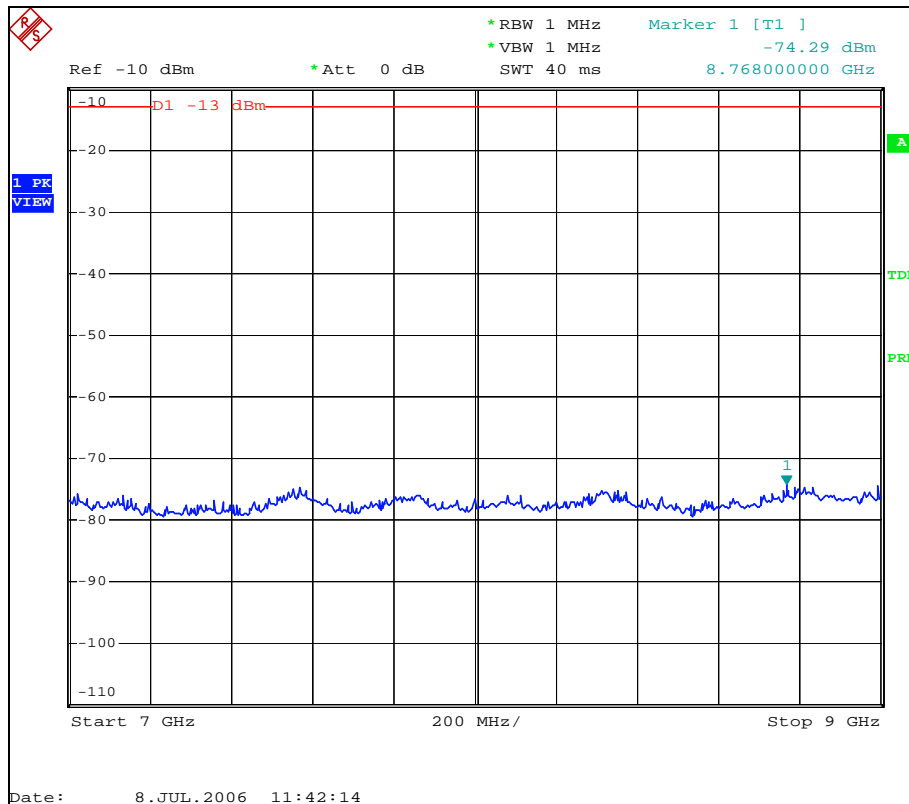



FOR GPRS MODE
CH 128: 9kHz ~ 1GHz

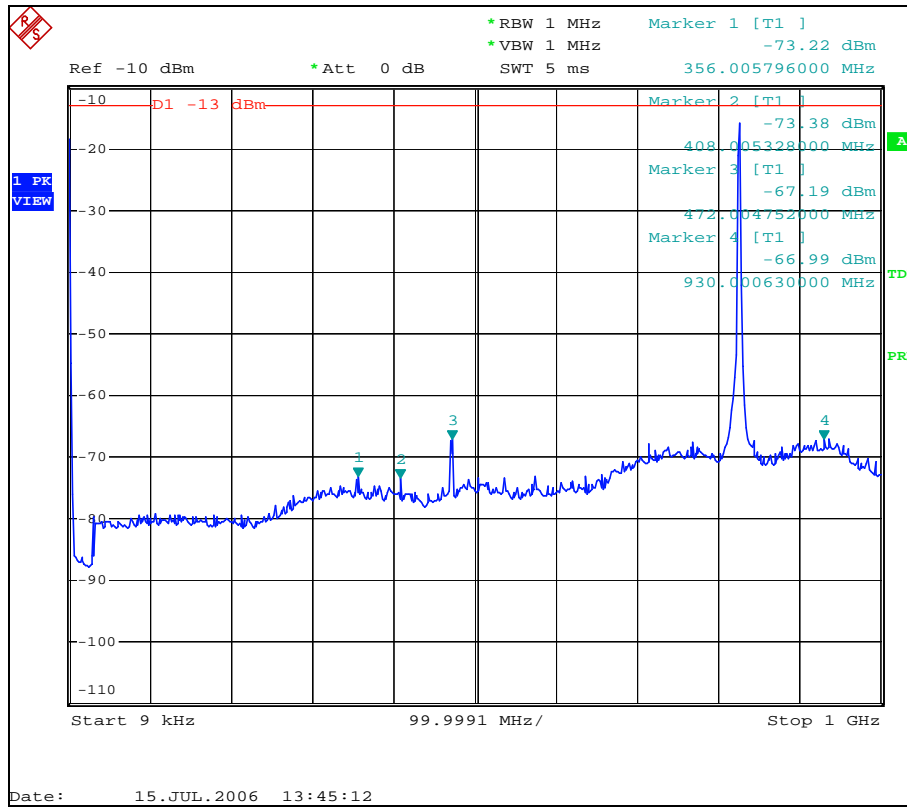

1GHz ~ 4GHz

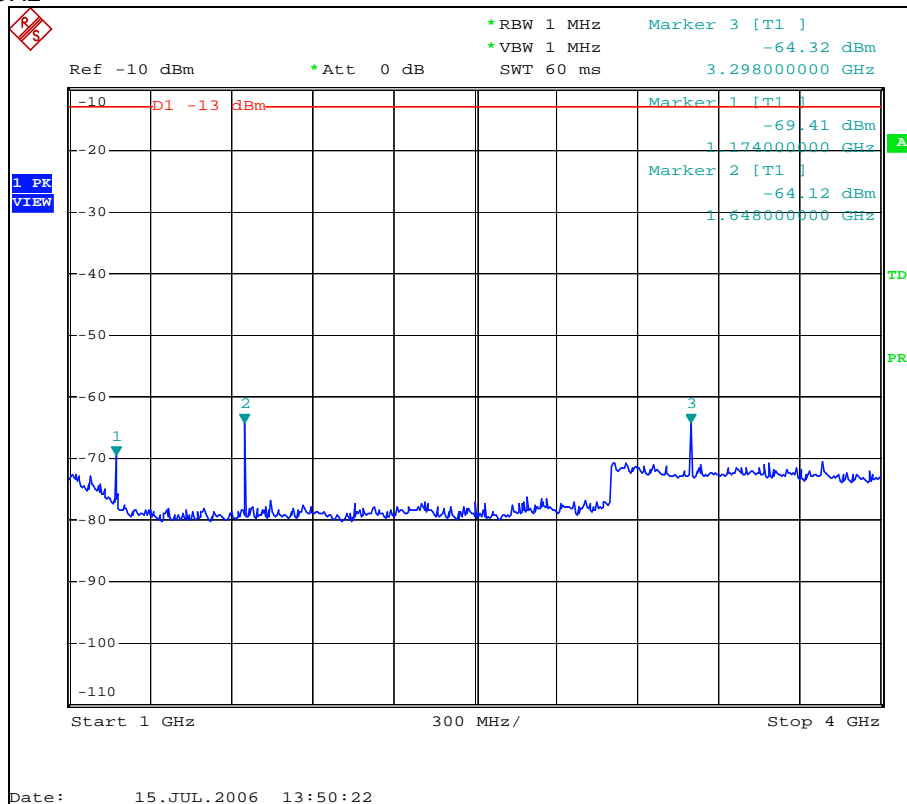



4GHz ~ 7GHz

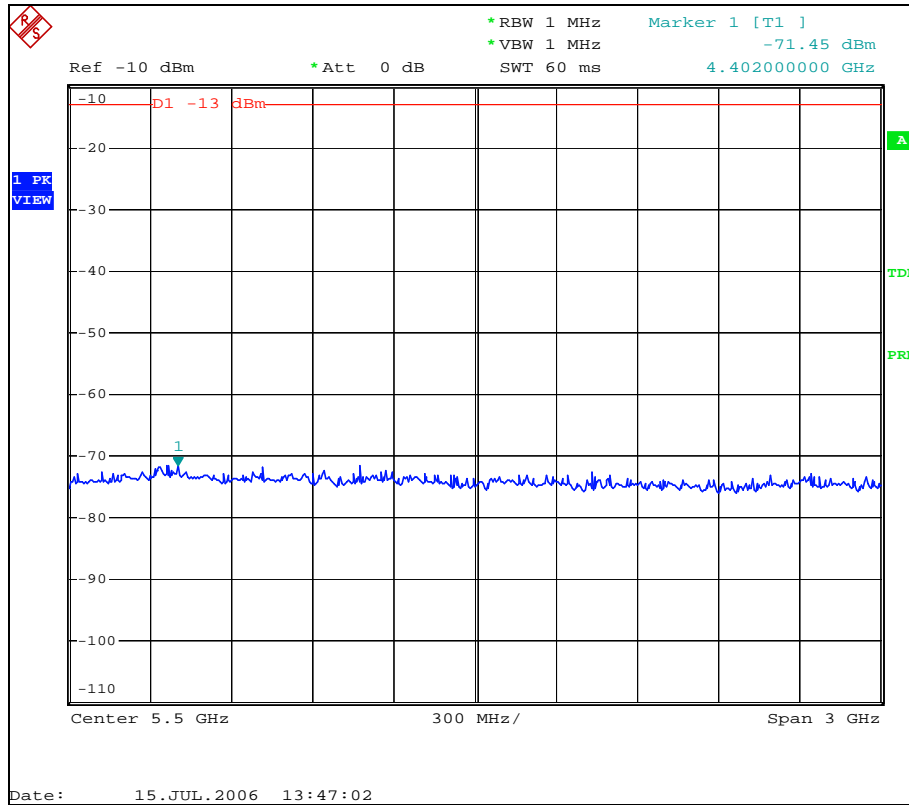

7GHz ~ 9GHz

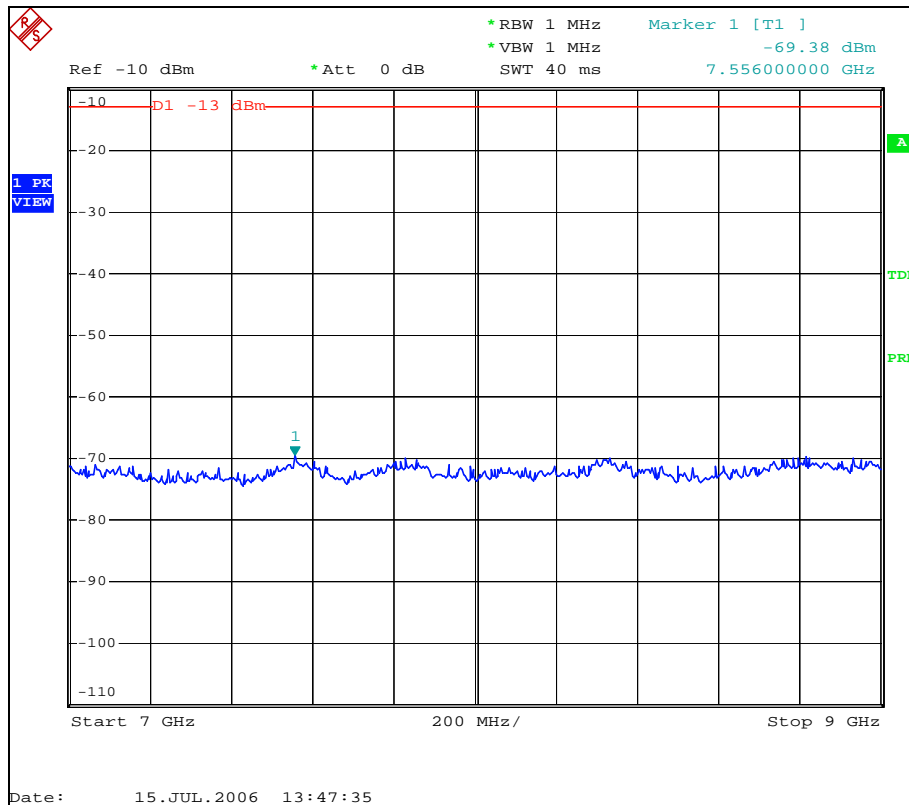

CH 190: 9kHz ~ 1GHz

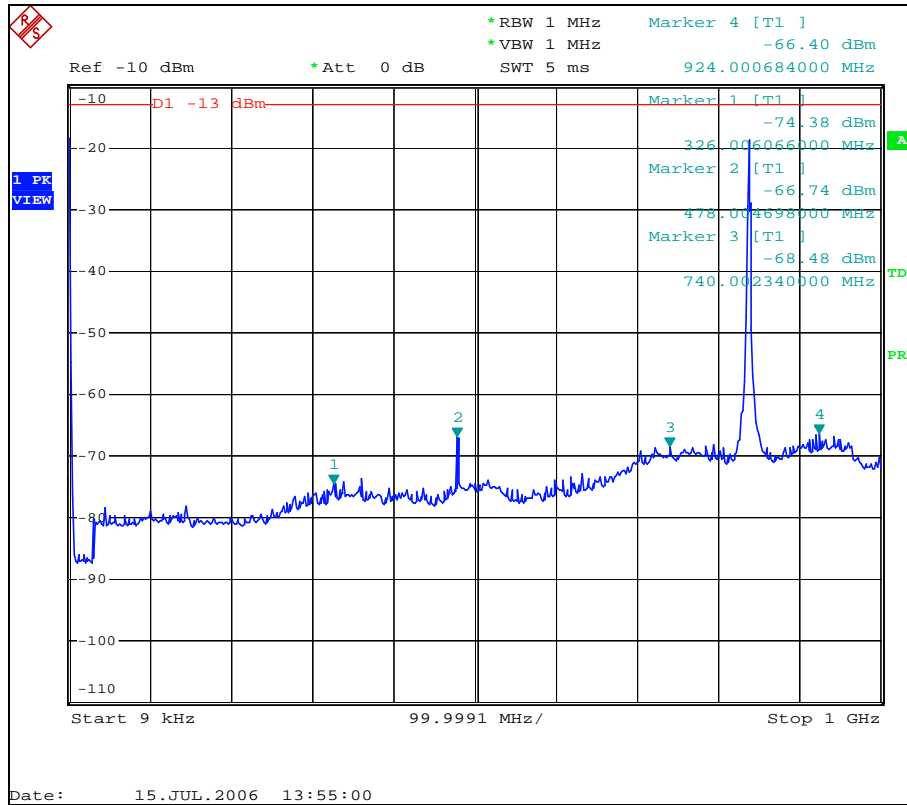

1GHz ~ 4GHz

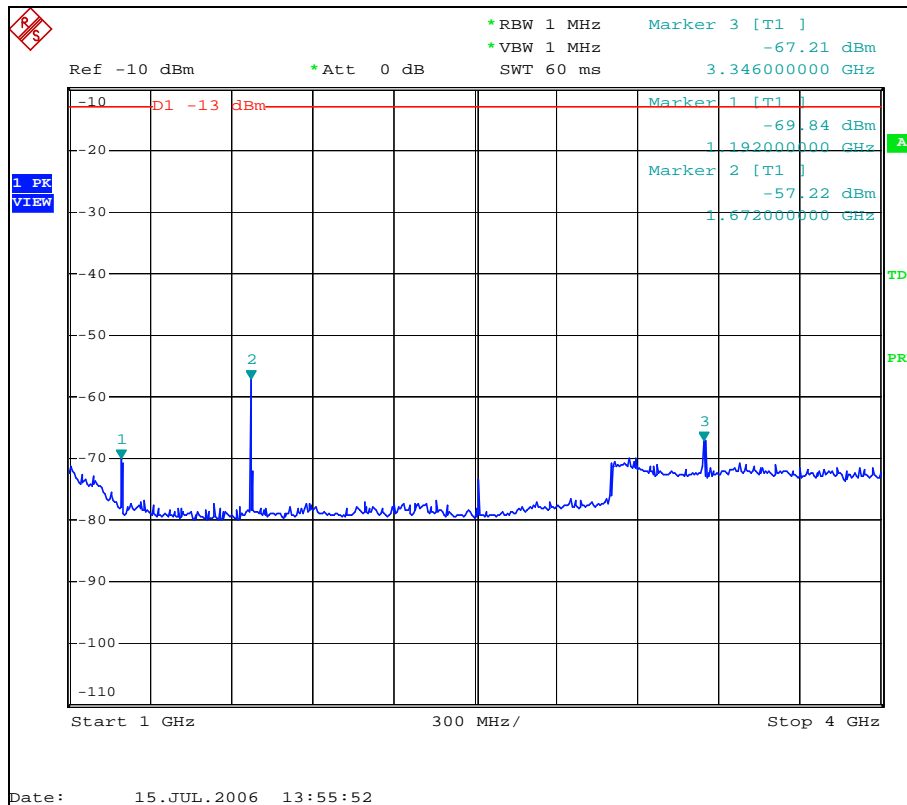



4GHz ~ 7GHz

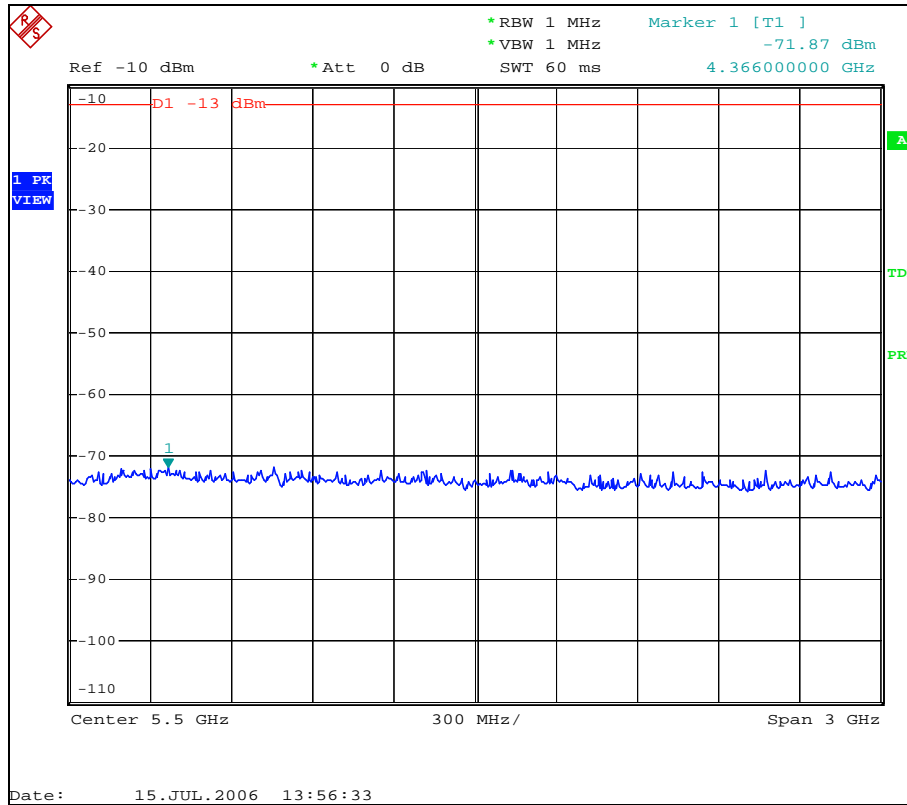

7GHz ~ 9GHz

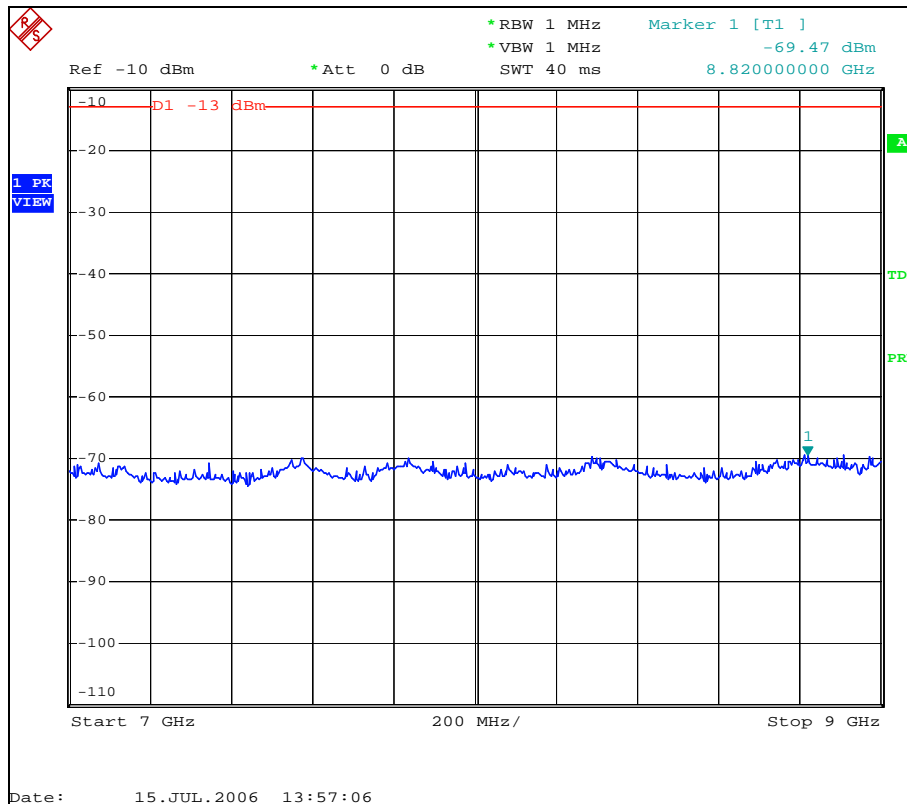

CH 251: 9kHz ~ 1GHz

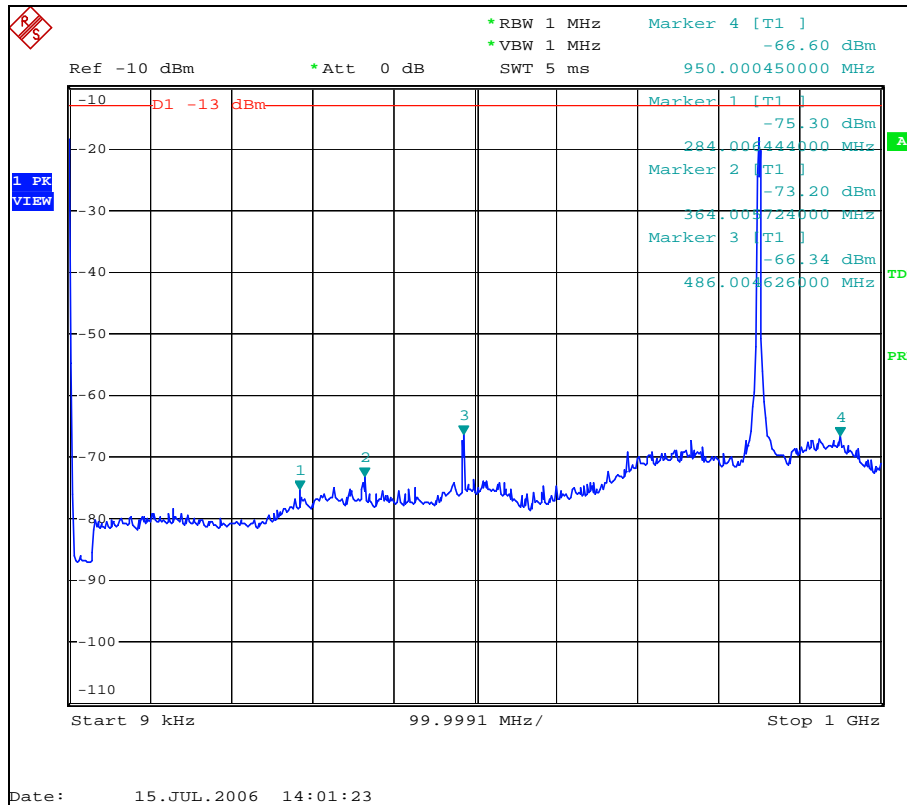

1GHz ~ 4GHz

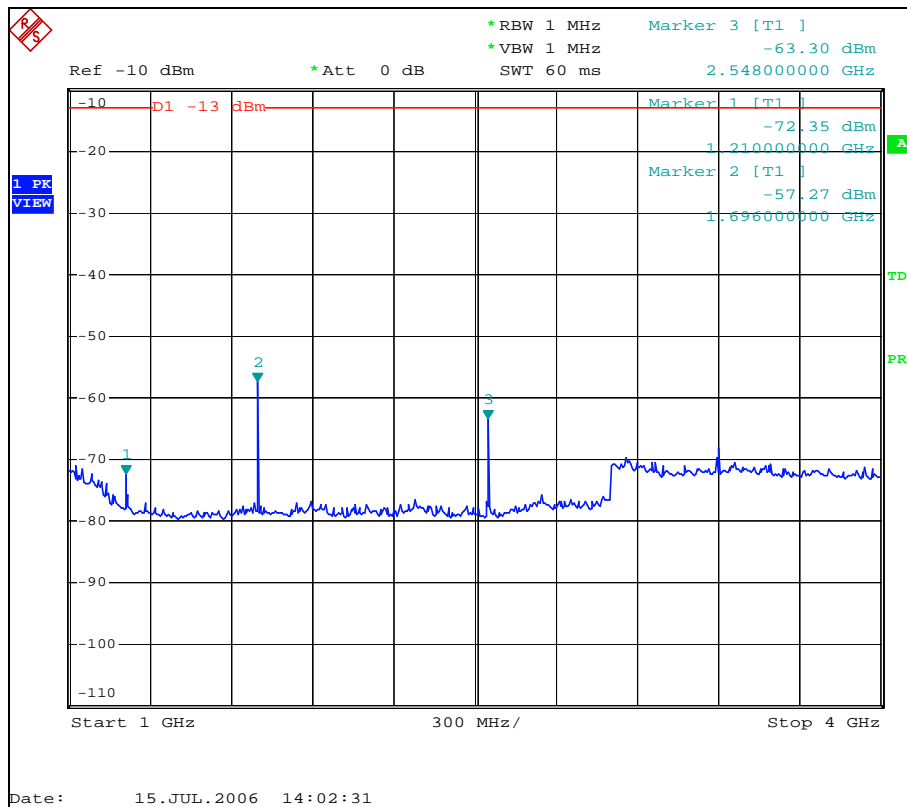



4GHz ~ 7GHz

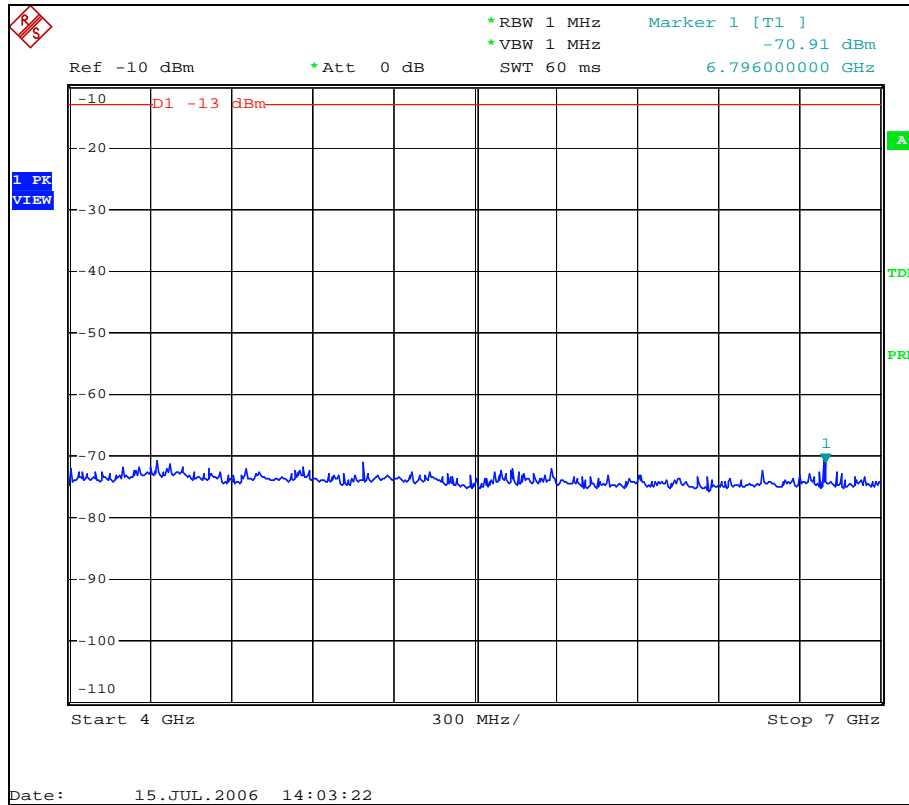

7GHz ~ 9GHz

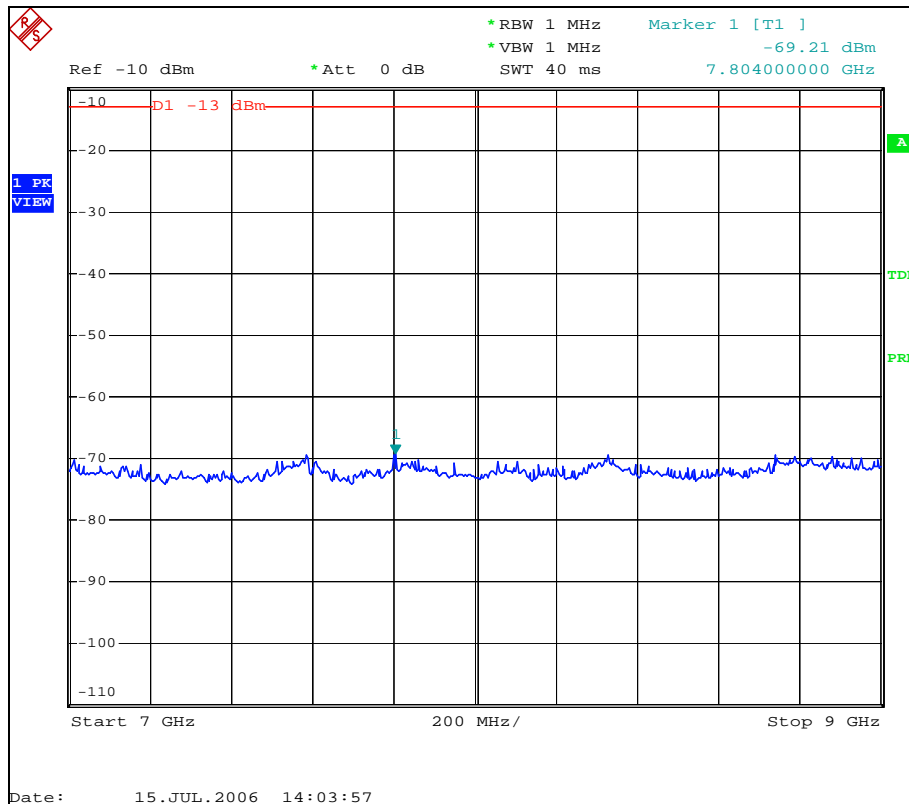

FOR GSM MODE

EUT	Dual Band GSM GPRS Mobile Phone	MODEL	M19
MODE	TX channel 128	POWER CONTROL LEVEL	5
INPUT POWER (SYSTEM)	120Vac, 60Hz	DETECTOR FUNCTION	Peak
ENVIRONMENTAL CONDITIONS	27deg. C, 60%RH, 991hPa	TESTED BY	Bright

CONDUCTED SPURIOUS EMISSION					
FREQUENCY (MHz)	CORRECTIO N FACTOR (dB)	S.A READING (dBm)	CONDUCTED LEVEL (dBm)	LIMIT (dBm)	MARGIN (dB)
144.41	1.1	-72.06	-70.96	-13	-57.96
354.01	1.5	-72.92	-71.42	-13	-58.42
472.00	1.6	-70.49	-68.89	-13	-55.89
1174.00	2.2	-72.75	-70.55	-13	-57.55
1648.00	2.7	-70.18	-67.48	-13	-54.48
2470.00	3.2	-67.9	-64.7	-13	-51.7
3298.00	3.9	-67.82	-63.92	-13	-50.92
4120.00	4.5	-72.14	-67.64	-13	-54.64
8812.00	6.5	-74.57	-68.07	-13	-55.07

REMARKS: 1. Peak Output Power (dBm) = Raw Value (dBm) + Correction Factor (dB).

EUT	Dual Band GSM GPRS Mobile Phone	MODEL	M19
MODE	TX channel 190	POWER CONTROL LEVEL	5
INPUT POWER (SYSTEM)	120Vac, 60Hz	DETECTOR FUNCTION	Peak
ENVIRONMENTAL CONDITIONS	27deg. C, 60%RH, 991hPa	TESTED BY	Bright

CONDUCTED SPURIOUS EMISSION					
FREQUENCY (MHz)	CORRECTIO N FACTOR (dB)	S.A READING (dBm)	CONDUCTED LEVEL (dBm)	LIMIT (dBm)	MARGIN (dB)
146.01	1.1	-72.45	-71.35	-13	-58.35
360.01	1.5	-75.95	-74.45	-13	-61.45
478.00	1.6	-71.02	-69.42	-13	-56.42
1198.00	2.2	-74.11	-71.91	-13	-58.91
1672.00	2.7	-62.39	-59.69	-13	-46.69
2512.00	3.2	-75.86	-72.66	-13	-59.66
3346.00	3.9	-70.32	-66.42	-13	-53.42
4180.00	4.5	-70.77	-66.27	-13	-53.27
7824.00	6.1	-74.74	-68.64	-13	-55.64

REMARKS: 1. Peak Output Power (dBm) = Raw Value (dBm) + Correction Factor (dB).

EUT	Dual Band GSM GPRS Mobile Phone	MODEL	M19
MODE	TX channel 251	POWER CONTROL LEVEL	5
INPUT POWER (SYSTEM)	120Vac, 60Hz	DETECTOR FUNCTION	Peak
ENVIRONMENTAL CONDITIONS	27deg. C, 60%RH, 991hPa	TESTED BY	Bright

CONDUCTED SPURIOUS EMISSION					
FREQUENCY (MHz)	CORRECTION FACTOR (dB)	S.A READING (dBm)	CONDUCTED LEVEL (dBm)	LIMIT (dBm)	MARGIN (dB)
134.81	1.1	-72.43	-71.33	-13	-58.33
364.01	1.5	-76.03	-74.53	-13	-61.53
484.00	1.6	-70.69	-69.09	-13	-56.09
1210.00	2.2	-76.74	-74.54	-13	-61.54
1696.00	2.7	-62.08	-59.38	-13	-46.38
2548.00	3.2	-52.15	-48.95	-13	-35.95
3400.00	3.9	-73.38	-69.48	-13	-56.48
4240.00	4.5	-66.55	-62.05	-13	-49.05
6796.00	5.8	-71.11	-65.31	-13	-52.31
8768.00	6.5	-74.29	-67.79	-13	-54.79

REMARKS: 1. Peak Output Power (dBm) = Raw Value (dBm) + Correction Factor (dB).

FOR GPRS MODE

EUT	Dual Band GSM GPRS Mobile Phone	MODEL	M19
MODE	TX channel 128	POWER CONTROL LEVEL	4
INPUT POWER (SYSTEM)	120Vac, 60Hz	DETECTOR FUNCTION	Peak
ENVIRONMENTAL CONDITIONS	27deg. C, 60%RH, 991hPa	TESTED BY	Bright

CONDUCTED SPURIOUS EMISSION					
FREQUENCY (MHz)	CORRECTIO N FACTOR (dB)	S.A READING (dBm)	CONDUCTED LEVEL (dBm)	LIMIT (dBm)	MARGIN (dB)
356.01	1.5	-73.22	-71.72	-13	-58.72
408.01	1.5	-73.38	-71.88	-13	-58.88
472	1.6	-67.19	-65.59	-13	-52.59
930	2.0	-66.99	-64.99	-13	-51.99
1174	2.2	-69.41	-67.21	-13	-54.21
1648	2.7	-64.12	-61.42	-13	-48.42
3298	3.9	-64.32	-60.42	-13	-47.42
4402	4.6	-71.45	-66.85	-13	-53.85
7556	6.0	-69.38	-63.38	-13	-50.38

REMARKS: 1. Peak Output Power (dBm) = Raw Value (dBm) + Correction Factor (dB).

EUT	Dual Band GSM GPRS Mobile Phone	MODEL	M19
MODE	TX channel 190	POWER CONTROL LEVEL	4
INPUT POWER (SYSTEM)	120Vac, 60Hz	DETECTOR FUNCTION	Peak
ENVIRONMENTAL CONDITIONS	27deg. C, 60%RH, 991hPa	TESTED BY	Bright

CONDUCTED SPURIOUS EMISSION					
FREQUENCY (MHz)	CORRECTIO N FACTOR (dB)	S.A READING (dBm)	CONDUCTED LEVEL (dBm)	LIMIT (dBm)	MARGIN (dB)
326.01	1.5	-74.38	-72.88	-13	-59.88
478.00	1.6	-66.74	-65.14	-13	-52.14
740.00	1.7	-68.48	-66.78	-13	-53.78
924.00	2.0	-66.4	-64.40	-13	-51.40
1192.00	2.2	-69.84	-67.64	-13	-54.64
1672.00	2.7	-57.22	-54.52	-13	-41.52
3348.00	3.9	-67.21	-63.31	-13	-50.31
4366.00	4.5	-71.87	-67.37	-13	-54.37
8820.00	6.5	-69.47	-62.97	-13	-49.97

REMARKS: 1. Peak Output Power (dBm) = Raw Value (dBm) + Correction Factor (dB).

EUT	Dual Band GSM GPRS Mobile Phone	MODEL	M19
MODE	TX channel 251	POWER CONTROL LEVEL	4
INPUT POWER (SYSTEM)	120Vac, 60Hz	DETECTOR FUNCTION	Peak
ENVIRONMENTAL CONDITIONS	27deg. C, 60%RH, 991hPa	TESTED BY	Bright

CONDUCTED SPURIOUS EMISSION					
FREQUENCY (MHz)	CORRECTIO N FACTOR (dB)	S.A READING (dBm)	CONDUCTED LEVEL (dBm)	LIMIT (dBm)	MARGIN (dB)
284.01	1.2	-75.3	-74.10	-13	-61.10
364.01	1.5	-73.2	-71.70	-13	-58.70
486.00	1.6	-66.34	-64.74	-13	-51.74
950.00	2	-66.6	-64.60	-13	-51.60
1210.00	2.2	-72.35	-70.15	-13	-57.15
1696.00	2.7	-57.27	-54.57	-13	-41.57
2548.00	3.2	-63.6	-60.40	-13	-47.40
6796.00	5.8	-70.91	-65.11	-13	-52.11
7804.00	6.1	-69.21	-63.11	-13	-50.11
284.01	1.2	-75.3	-74.10	-13	-61.10

REMARKS: 1. Peak Output Power (dBm) = Raw Value (dBm) + Correction Factor (dB).

4.7 RADIATED EMISSION MEASUREMENT (BELOW 1GHz)

4.7.1 LIMITS OF RADIATED EMISSION MEASUREMENT

In the FCC 22.917, on any frequency outside a licensee's frequency block within USPCS spectrum, the power of any emission shall be attenuated below the transmitter power (P) by at least $43 + 10 \log (P)$ dB. The limit translates in the relevant power range (2 to 0.003W). At 2W (Power Control Level 3) the specified minimum attenuation becomes 43dB and the limit of emission equal to -13dBm .

4.7.2 TEST INSTRUMENTS

DESCRIPTION & MANUFACTURER	MODEL NO.	SERIAL NO.	CALIBRATED UNTIL
Test Receiver ROHDE & SCHWARZ	ESCS30	E1R1001	Apr. 19, 2007
BILOG Antenna SCHWARZBECK	VULB9168	E1A1001	Sep. 26, 2006
Preamplifier Agilent	8447D	E1A2001	Jan. 27, 2007
Preamplifier Agilent	8449B	E1A2002	Jan. 27, 2007
Double Ridged Broadband Horn Antenna Schwarzbeck	BBHA 9120D	E1A1002	Feb.15, 2007
Spectrum Analyzer Agilent	E4403B	E1S1001	Jan. 13, 2007
Spectrum Analyzer ROHDE & SCHWARZ	FSP30	E1S1002	May.15, 2007
RF signal cable Woken	RG-402	E1CBH01	May. 30, 2007
RF signal cable Woken	RG-402	E1CBH02	May. 30, 2007
RF signal cable Woken	RG-402	E1CBH03	May. 30, 2007
RF signal cable Woken	RG-412	E1CBL02	May. 30, 2007
RF signal cable Woken	RG-412	E1CBL03	May. 30, 2007
RF signal cable Woken	RG-412	E1CBL04	May. 30, 2007
Software ADT	ADT_Radiated_V7.5	N/A	N/A

- NOTE:**
1. The calibration interval of the above test instruments is 12 months.
 2. The horn antenna and Agilent preamplifier (model: 8449B) are used only for the measurement of emission frequency above 1GHz if tested.
 3. The Spectrum Analyzer (model: FSP30) and RF signal cable (SERIAL: E1CBH05&E1CBH07) are used only for the measurement of emission frequency above 1GHz if tested.

4.7.3 TEST PROCEDURES

- a. The EUT was placed on the top of a rotating table 0.8 meters above the ground. The table was rotated 360 degrees to determine the position of the highest radiation.
- b. The EUT was set 3 meters away from the receiving antenna, which was mounted on antenna tower and its position at 0.8 m above the ground.
- c. For each suspected emission, the EUT was arranged to its worst case and the rotatable table was turned from 0 degrees to 360 degrees to find the maximum reading and recorded the value.
- d. Repeat step a ~ c for horizontal polarization.

- NOTE:**
1. The resolution bandwidth of spectrum analyzer is 10 kHz and the video bandwidth is 300 kHz for spurious emission below 1GHz.
 2. The resolution bandwidth of spectrum analyzer is 1 MHz and the video bandwidth is 3 MHz for spurious emission above 1GHz.
 3. The resolution bandwidth of spectrum analyzer is 100 kHz and the video bandwidth is 100 kHz for the transmitter output measurement.

4.7.4 DEVIATION FROM TEST STANDARD

No deviation

4.7.5 TEST SETUP

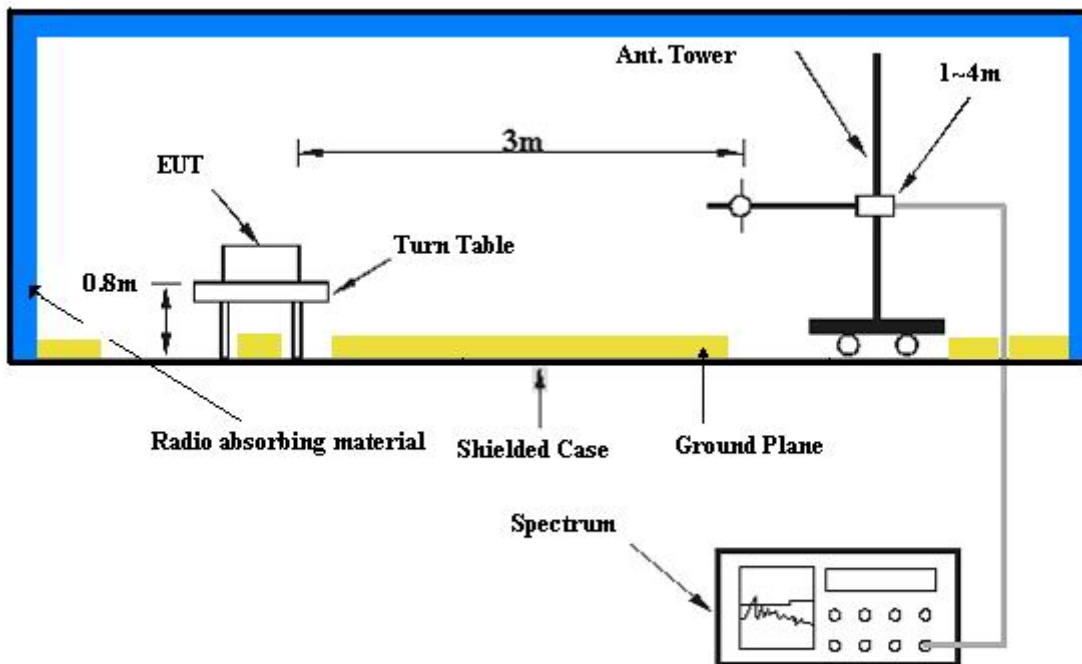

For the actual test configuration, please refer to the related item – Photographs of the Test Configuration.

4.7.6 EUT OPERATING CONDITIONS

- a. The notebook system makes a phone call to the GSM simulator.
- b. The GSM simulator station system controlled an EUT to export maximum output power under transmission mode and specific channel frequency.

4.7.7 TEST RESULTS

FOR MODE A

EUT	Dual Band GSM GPRS Mobile Phone	MODEL	M19
MODE	TX channel 128	FREQUENCY RANGE	Below 1000 MHz
INPUT POWER (SYSTEM)	120Vac, 60Hz	DETECTOR FUNCTION	Quasi-Peak
ENVIRONMENTAL CONDITIONS	24deg. C, 66%RH, 991hPa	TESTED BY	Bright

ANTENNA POLARITY & TEST DISTANCE: HORIZONTAL AT 3 M

No.	Freq. (MHz)	Factor (dB/M)	Reading (dBuV/M)	Emission (dBuV/M)	Limit (dBuV/M)	Margin (dB)	Ant. Height (cm)	Table Angle (Deg.)
1	56.67	15.01	-7.68	7.33	40	-32.67	99	35
2	158.53	17.06	-7.94	9.11	40	-30.89	99	88
3	331.4	17.22	-4.3	12.92	47	-34.08	99	143
4	492.35	20.76	-2.79	17.97	47	-29.03	112	207
5	599.87	23.13	-7.98	15.15	47	-31.85	99	261
6	742.95	25.26	-8.5	16.76	47	-30.24	99	341

ANTENNA POLARITY & TEST DISTANCE: VERTICAL AT 3 M

No.	Freq. (MHz)	Factor (dB/M)	Reading (dBuV/M)	Emission (dBuV/M)	Limit (dBuV/M)	Margin (dB)	Ant. Height (cm)	Table Angle (Deg.)
1	46.98	15.49	-8.45	7.05	40	-32.95	156	311
2	160.95	16.98	-8.26	8.72	40	-31.28	100	223
3	369.27	18.01	3.79	21.8	47	-25.2	124	163
4	493.18	20.77	-7.65	13.12	47	-33.88	100	95
5	619.27	23.49	-8.26	15.23	47	-31.77	119	52
6	711.25	24.81	-5.45	19.36	47	-27.64	99	0

NOTE:

1. Emission level (dBuV/m) = Raw Value (dBuV) + Correction Factor (dB).
2. Correction Factor (dB/m) = Antenna Factor (dB/m) + Cable Factor (dB).
3. The other emission levels were very low against the limit.
4. Margin value = Emission level – Limit value.
5. This is valid for all 3 channels.

FOR MODE B

EUT	Dual Band GSM GPRS Mobile Phone	MODEL	M19
MODE	TX channel 128	FREQUENCY RANGE	Below 1000 MHz
INPUT POWER (SYSTEM)	120Vac, 60Hz	DETECTOR FUNCTION	Quasi-Peak
ENVIRONMENTAL CONDITIONS	24deg. C, 66%RH, 991hPa	TESTED BY	Bright

ANTENNA POLARITY & TEST DISTANCE: HORIZONTAL AT 3 M

No.	Freq. (MHz)	Factor (dB/M)	Reading (dBuV/M)	Emission (dBuV/M)	Limit (dBuV/M)	Margin (dB)	Ant. Height (cm)	Table Angle (Deg.)
1	37.27	15.56	2.74	18.3	40	-21.7	206	329
2	158.53	17.06	-7.47	9.58	43.5	-33.92	153	71
3	350.33	17.48	6.05	23.53	46	-22.47	140	88
4	445.02	19.99	1.51	21.51	46	-24.49	210	216
5	604.73	23.22	-7.61	15.61	46	-30.39	182	318
6	728.4	25.12	-8.46	16.66	46	-29.34	140	299

ANTENNA POLARITY & TEST DISTANCE: VERTICAL AT 3 M

No.	Freq. (MHz)	Factor (dB/M)	Reading (dBuV/M)	Emission (dBuV/M)	Limit (dBuV/M)	Margin (dB)	Ant. Height (cm)	Table Angle (Deg.)
1	34.73	15.25	21.74	36.98	40	-3.02	99	217
2	119.72	14.74	-0.3	14.43	43.5	-29.07	132	107
3	350.33	17.48	1.02	18.5	46	-27.5	177	210
4	507.73	21.03	-8.04	13	46	-33	163	308
5	614.42	23.4	-7.8	15.6	46	-30.4	158	269
6	730.83	25.15	-8.46	16.68	46	-29.32	157	197

NOTE:

1. Emission level (dBuV/m) = Raw Value (dBuV) + Correction Factor (dB).
2. Correction Factor (dB/m) = Antenna Factor (dB/m) + Cable Factor (dB).
3. The other emission levels were very low against the limit.
4. Margin value = Emission level – Limit value.
5. This is valid for all 3 channels.

FOR MODE C

EUT	Dual Band GSM GPRS Mobile Phone	MODEL	M19
MODE	TX channel 128	FREQUENCY RANGE	Below 1000 MHz
INPUT POWER (SYSTEM)	120Vac, 60Hz	DETECTOR FUNCTION	Quasi-Peak
ENVIRONMENTAL CONDITIONS	24deg. C, 66%RH, 991hPa	TESTED BY	Bright

ANTENNA POLARITY & TEST DISTANCE: HORIZONTAL AT 3 M

No.	Freq. (MHz)	Factor (dB/M)	Reading (dBuV/M)	Emission (dBuV/M)	Limit (dBuV/M)	Margin (dB)	Ant. Height (cm)	Table Angle (Deg.)
1	124.58	15.04	-7.87	7.17	43.5	-36.33	163	60
2	198.84	13.01	-0.93	12.08	43.5	-31.42	99	0
3	350.33	17.48	5.61	23.09	46	-22.91	166	121
4	529.55	21.52	-7.91	13.61	46	-32.39	138	193
5	675.05	24.18	-7.95	16.23	46	-29.77	111	172
6	796.3	25.79	-7.49	18.3	46	-27.7	162	261

ANTENNA POLARITY & TEST DISTANCE: VERTICAL AT 3 M

No.	Freq. (MHz)	Factor (dB/M)	Reading (dBuV/M)	Emission (dBuV/M)	Limit (dBuV/M)	Margin (dB)	Ant. Height (cm)	Table Angle (Deg.)
1	35.95	15.39	1.38	16.77	40	-23.23	99	303
2	165.8	16.51	-3.69	12.83	43.5	-30.67	150	251
3	350.32	17.48	2.1	19.58	46	-26.42	146	318
4	531.98	21.58	-7.59	14	46	-32	184	234
5	643.52	23.81	-8.28	15.53	46	-30.47	149	156
6	813.27	26.11	-8.39	17.71	46	-28.29	142	226

NOTE:

1. Emission level (dBuV/m) = Raw Value (dBuV) + Correction Factor (dB).
2. Correction Factor (dB/m) = Antenna Factor (dB/m) + Cable Factor (dB).
3. The other emission levels were very low against the limit.
4. Margin value = Emission level – Limit value.
5. This is valid for all 3 channels.

4.8 EFFECTIVE RADIATED POWER MEASUREMENT (ABOVE 1GHz)

4.8.1 LIMITS OF RADIATED EMISSION MEASUREMENT

In the FCC 22.917 (a), on any frequency outside a licensee's frequency block within GSM spectrum, the power of any emission shall be attenuated below the transmitter power (P) by at least $43 + 10 \log (P)$ dB. The limit translates in the relevant power range (2 to 0.003W). At 2W (Power Control Level 3) the specified minimum attenuation becomes 43dB and the limit of emission equal to -13dBm .

4.8.2 TEST INSTRUMENTS

DESCRIPTION & MANUFACTURER	MODEL NO.	SERIAL NO.	CALIBRATED UNTIL
Test Receiver ROHDE & SCHWARZ	ESCS30	E1R1001	Apr. 19, 2007
Spectrum Analyzer ROHDE & SCHWARZ	FSP30	E1S1002	May. 16, 2007
BILOG Antenna SCHWARZBECK	VULB9168	E1A1001	Sep. 26, 2006
HORN Antenna SCHWARZBECK	BBHA 9120D	E1A1002	Feb. 14, 2007
HORN Antenna SCHWARZBECK	BBHA 9170	E1A1003	Feb. 14, 2007
Double Ridge Horn Com-Power	AH-118	71053	Jun. 24, 2007
Signal Generator IFR	2025	E1S9001	Apr. 3, 2007
Preamplifier Agilent	8447D	E1A2001	Jan. 26, 2007
Preamplifier Agilent	8449B	E1A2002	Jan. 26, 2007
Software ADT	ADT_Radiated_V7.5	N/A	N/A

- NOTE:**
1. The calibration interval of the above test instruments is 12 months and the calibrations are traceable to NML/ROC and NIST/USA.
 2. The horn antenna and Agilent preamplifier (model: 8449B) are used only for the measurement of emission frequency above 1GHz if tested.

4.8.3 TEST PROCEDURES

- a. The EUT was placed on the top of a rotating table 0.8 meters above the ground. The table was rotated 360 degrees to determine the position of the highest radiation.
- b. The EUT was set 3 meters away from the receiving antenna, which was mounted on antenna tower and its position at 0.8 m above the ground.
- c. For each suspected emission, the EUT was arranged to its worst case and the rotatable table was turned from 0 degrees to 360 degrees to find the maximum reading and recorded the value.
- d. The EUT is replaced by a horn antenna connected to a signal generator tuned to the frequency of emission.
- e. The signal generator level has to be adjusted to have the same emission nature.
- f. The radiated power can be calculated via the factor and antenna gain.
- g. Repeat step a ~ f for horizontal polarization.

NOTE: 1. The resolution bandwidth of spectrum analyzer is 10 kHz and the video bandwidth is 300 kHz for spurious emission below 1GHz.
2. The resolution bandwidth of spectrum analyzer is 1 MHz and the video bandwidth is 3 MHz for spurious emission above 1GHz.
3. The resolution bandwidth of spectrum analyzer is 100 kHz and the video bandwidth is 100 kHz for the transmitter output measurement.

4.8.4 DEVIATION FROM TEST STANDARD

No deviation

4.8.5 TEST SETUP

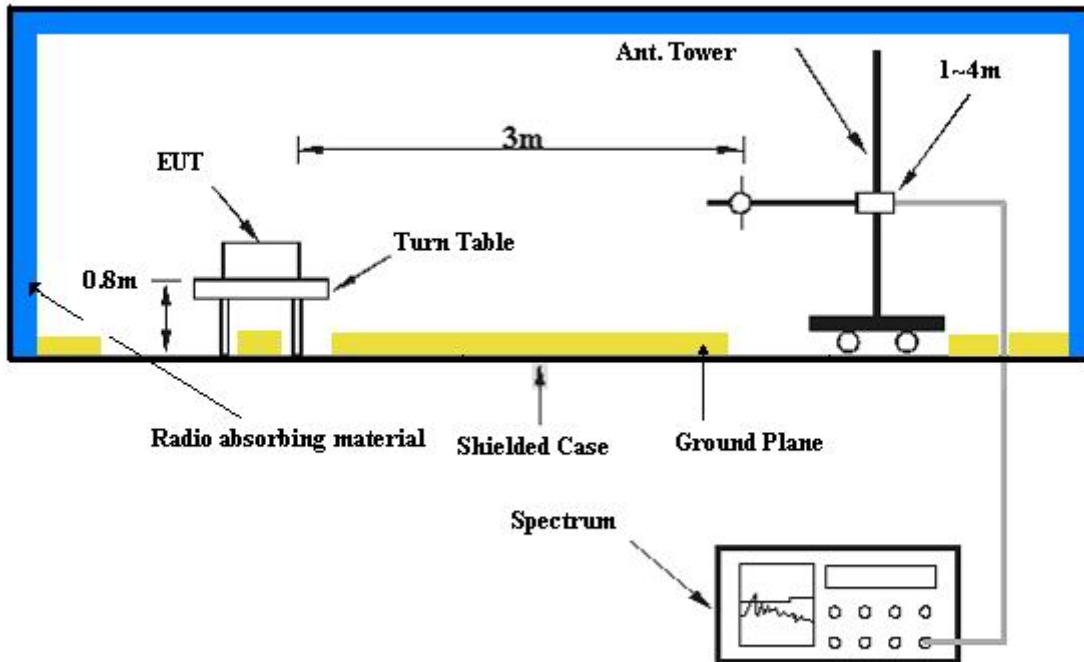

For the actual test configuration, please refer to the related item – Photographs of the Test Configuration.

4.8.6 EUT OPERATING CONDITIONS

- a. The notebook system makes a phone call to the GSM simulator.
- b. The GSM simulator station system controlled an EUT to export maximum output power under transmission mode and specific channel frequency.

4.8.7 TEST RESULTS

FOR GSM MODE

EUT	Dual Band GSM GPRS Mobile Phone	MODEL	M19
MODE	TX channel 128	FREQUENCY RANGE	Above 1000 MHz
INPUT POWER (SYSTEM)	120Vac, 60Hz	ENVIRONMENTAL CONDITIONS	24deg. C, 62%RH, 991hPa
TESTED BY	Bright		

ANTENNA POLARITY & TEST DISTANCE: HORIZONTAL AT 3 M				
No.	Freq. (MHz)	Emission Level (dBm)	Limit (dBm)	Margin(dB)
1	1648.4	-49.49	-13	-36.49
2	2472.6	-46.94	-13	-33.94
3	3296.8	-48.24	-13	-35.24
4	4121	-43.69	-13	-30.69
5	4945.2	-43.23	-13	-30.23
6	5769.4	-40.71	-13	-27.71
7	6593.6	-36.97	-13	-23.97
8	7417.8	-35.85	-13	-22.85
9	8242	-33.04	-13	-20.04

ANTENNA POLARITY & TEST DISTANCE: VERTICAL AT 3 M				
No.	Freq. (MHz)	Emission Level (dBm)	Limit (dBm)	Margin (dB)
1	1648.4	-51.93	-13	-38.93
2	2472.6	-49.93	-13	-36.93
3	3296.8	-50.96	-13	-37.96
4	4121	-43.92	-13	-30.92
5	4945.2	-43.13	-13	-30.13
6	5769.4	-40.97	-13	-27.97
7	6593.6	-37.5	-13	-24.5
8	7417.8	-35.12	-13	-22.12
9	8242	-33.68	-13	-20.68

EUT	Dual Band GSM GPRS Mobile Phone	MODEL	M19
MODE	TX channel 190	FREQUENCY RANGE	Above 1000 MHz
INPUT POWER (SYSTEM)	120Vac, 60Hz	ENVIRONMENTAL CONDITIONS	24deg. C, 62%RH, 991hPa
TESTED BY	Bright		

ANTENNA POLARITY & TEST DISTANCE: HORIZONTAL AT 3 M				
No.	Freq. (MHz)	Emission Level (dBm)	Limit (dBm)	Margin(dB)
1	1673.2	-49.43	-13	-36.43
2	2509.8	-50.45	-13	-37.45
3	3346.4	-50.48	-13	-37.48
4	4183	-43.21	-13	-30.21
5	5019.6	-41.5	-13	-28.5
6	5856.2	-40.94	-13	-27.94
7	6692.8	-37.12	-13	-24.12
8	7529.4	-34.4	-13	-21.4
9	8366	-32.66	-13	-19.66

ANTENNA POLARITY & TEST DISTANCE: VERTICAL AT 3 M				
No.	Freq. (MHz)	Emission Level (dBm)	Limit (dBm)	Margin (dB)
1	1673.2	-50.11	-13	-37.11
2	2509.8	-50.14	-13	-37.14
3	3346.4	-50.39	-13	-37.39
4	4183	-43.53	-13	-30.53
5	5019.6	-40.06	-13	-27.06
6	5856.2	-40.45	-13	-27.45
7	6692.8	-38.34	-13	-25.34
8	7529.4	-34.88	-13	-21.88
9	8366	-31.97	-13	-18.97

NOTE: Power Value (dBum) = S.G Power Value (dBm) + Correction Factor (dB).

EUT	Dual Band GSM GPRS Mobile Phone	MODEL	M19
MODE	TX channel 251	FREQUENCY RANGE	Above 1000 MHz
INPUT POWER (SYSTEM)	120Vac, 60Hz	ENVIRONMENTAL CONDITIONS	24deg. C, 62%RH, 991hPa
TESTED BY	Bight		

ANTENNA POLARITY & TEST DISTANCE: HORIZONTAL AT 3 M				
No.	Freq. (MHz)	Emission Level (dBm)	Limit (dBm)	Margin(dB)
1	1697.6	-50.91	-13	-37.91
2	2546.4	-50.52	-13	-37.52
3	3395.2	-49.92	-13	-36.92
4	4244	-42.34	-13	-29.34
5	5092.8	-41.96	-13	-28.96
6	5941.6	-41.58	-13	-28.58
7	6790.4	-38.13	-13	-25.13
8	7639.2	-34.28	-13	-21.28
9	8488	-34.02	-13	-21.02

ANTENNA POLARITY & TEST DISTANCE: VERTICAL AT 3 M				
No.	Freq. (MHz)	Emission Level (dBm)	Limit (dBm)	Margin (dB)
1	1673.2	-51.16	-13	-38.16
2	2509.8	-50.58	-13	-37.58
3	3346.4	-50.22	-13	-37.22
4	4183	-43.21	-13	-30.21
5	5019.6	-42.28	-13	-29.28
6	5856.2	-41.38	-13	-28.38
7	6692.8	-37.91	-13	-24.91
8	7529.4	-34.16	-13	-21.16
9	8366	-32.52	-13	-19.52

FOR GPRS MODE

EUT	Dual Band GSM GPRS Mobile Phone	MODEL	M19
MODE	TX channel 128	FREQUENCY RANGE	Above 1000 MHz
INPUT POWER (SYSTEM)	120Vac, 60Hz	ENVIRONMENTAL CONDITIONS	24deg. C, 62%RH, 991hPa
TESTED BY	Bright		

ANTENNA POLARITY & TEST DISTANCE: HORIZONTAL AT 3 M				
No.	Freq. (MHz)	Emission Level (dBm)	Limit (dBm)	Margin(dB)
1	1648.4	-49.51	-13	-36.51
2	2472.6	-47.19	-13	-34.19
3	3296.8	-48.2	-13	-35.2
4	4121	-44.13	-13	-31.13
5	4945.2	-43.22	-13	-30.22
6	5769.4	-41.07	-13	-28.07
7	6593.6	-36.93	-13	-23.93
8	7417.8	-36.01	-13	-23.01
9	8242	-32.82	-13	-19.82

ANTENNA POLARITY & TEST DISTANCE: VERTICAL AT 3 M				
No.	Freq. (MHz)	Emission Level (dBm)	Limit (dBm)	Margin (dB)
1	1648.4	-51.78	-13	-38.78
2	2472.6	-50.04	-13	-37.04
3	3296.8	-50.85	-13	-37.85
4	4121	-43.84	-13	-30.84
5	4945.2	-43.02	-13	-30.02
6	5769.4	-40.8	-13	-27.8
7	6593.6	-37.35	-13	-24.35
8	7417.8	-34.74	-13	-21.74
9	8242	-33.74	-13	-20.74

EUT	Dual Band GSM GPRS Mobile Phone	MODEL	M19
MODE	TX channel 190	FREQUENCY RANGE	Above 1000 MHz
INPUT POWER (SYSTEM)	120Vac, 60Hz	ENVIRONMENTAL CONDITIONS	24deg. C, 62%RH, 991hPa
TESTED BY	Bright		

ANTENNA POLARITY & TEST DISTANCE: HORIZONTAL AT 3 M				
No.	Freq. (MHz)	Emission Level (dBm)	Limit (dBm)	Margin(dB)
1	1673.2	-48.89	-13	-35.89
2	2509.8	-50.33	-13	-37.33
3	3346.4	-51.14	-13	-38.14
4	4183	-43.81	-13	-30.81
5	5019.6	-41.3	-13	-28.3
6	5856.2	-41.11	-13	-28.11
7	6692.8	-37.5	-13	-24.5
8	7529.4	-34.01	-13	-21.01
9	8366	-32.81	-13	-19.81

ANTENNA POLARITY & TEST DISTANCE: VERTICAL AT 3 M				
No.	Freq. (MHz)	Emission Level (dBm)	Limit (dBm)	Margin (dB)
1	1673.2	-52.08	-13	-39.08
2	2509.8	-51.41	-13	-38.41
3	3346.4	-50.09	-13	-37.09
4	4183	-42.79	-13	-29.79
5	5019.6	-41.73	-13	-28.73
6	5856.2	-41.59	-13	-28.59
7	6692.8	-37.84	-13	-24.84
8	7529.4	-34.24	-13	-21.24
9	8366	-32.89	-13	-19.89

EUT	Dual Band GSM GPRS Mobile Phone	MODEL	M19
MODE	TX channel 251	FREQUENCY RANGE	Above 1000 MHz
INPUT POWER (SYSTEM)	120Vac, 60Hz	ENVIRONMENTAL CONDITIONS	24deg. C, 62%RH, 991hPa
TESTED BY	Bright		

ANTENNA POLARITY & TEST DISTANCE: HORIZONTAL AT 3 M

No.	Freq. (MHz)	Emission Level (dBm)	Limit (dBm)	Margin(dB)
1	1697.6	-51.16	-13	-38.16
2	2546.4	-50.91	-13	-37.91
3	3395.2	-49.68	-13	-36.68
4	4244	-41.63	-13	-28.63
5	5092.8	-41.77	-13	-28.77
6	5941.6	-41.48	-13	-28.48
7	6790.4	-37.88	-13	-24.88
8	7639.2	-34.71	-13	-21.71
9	8488	-33.66	-13	-20.66

ANTENNA POLARITY & TEST DISTANCE: VERTICAL AT 3 M

No.	Freq. (MHz)	Emission Level (dBm)	Limit (dBm)	Margin (dB)
1	1697.6	-51.52	-13	-38.52
2	2546.4	-50.68	-13	-37.68
3	3395.2	-50.04	-13	-37.04
4	4244	-43.01	-13	-30.01
5	5092.8	-41.6	-13	-28.6
6	5941.6	-41.91	-13	-28.91
7	6790.4	-38.06	-13	-25.06
8	7639.2	-33.89	-13	-20.89
9	8488	-32.93	-13	-19.93

5 INFORMATION ON THE TESTING LABORATORIES

We, ADT (Shanghai) Corp., were founded in 2003 to provide our best service in EMC, Radio, Telecom and Safety consultation. Our laboratories are accredited and approved by the following approval agencies according to ISO/IEC 17025.

JAPAN	VCCI
USA	FCC, A2LA
Norway	DNV



Copies of accreditation certificates of our laboratories obtained from approval agencies can be downloaded from our web site: www.cnadt.com

If you have any comments, please feel free to contact us at the following:

ADT (Shanghai) Corporation

TEL :86-21-6465-9091

Fax : 86-21-6465-9092

Email: adtsh@vip.163.com

Web Site: www.cnadt.com