

DOT MATRIX PRINTER

GSX-190II

USER'S MANUAL

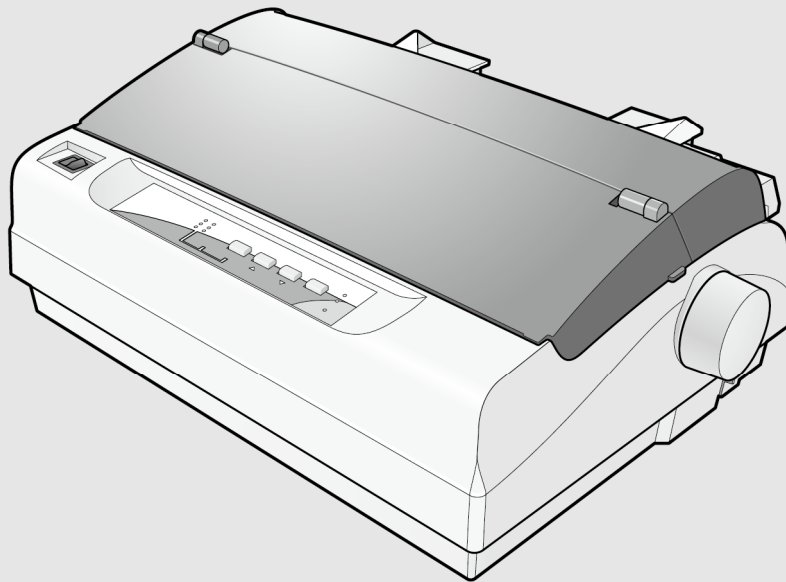

Important Safety Instructions

Read all of these instructions carefully and thoroughly and save them for later reference. The unauthorized operation would lead to malfunction or accident. Manufacturers have no responsibilities for the problems which are led by misoperations.

1. Follow all warnings and instructions in the manual as well as marked on the product.
2. If the printer has been used just now, please not touch the print head for overheating.
3. Do not put your fingers under the left and right tractor sprocket covers of the tractor when installing the tractor paper.
4. Unplug this product from the power outlet before cleaning. Do not use liquid or aerosol cleaners. Use a damp cloth for cleaning.
5. Do not use this product near water.
6. Do not place this product on an unstable cart, stand or table. The product may fall, causing serious damage to you or the product.
7. Slots and openings on the cabinet and the back or bottom are provided for air ventilation. To ensure reliable operation of the product and to protect it from overheating, do not block or cover these openings. The openings should never be blocked by placing the product on a bed, sofa, rug or other similar surface. This product should never be placed near or over a radiator or heater. This product should not be placed in a built-in installation or kiosk stand unless proper ventilation is provided.
8. This product should never be placed near or over a radiator or heat origin, and should avoid of direct sunshine.
9. Do not locate this product where the cord would be walked on. When the cord or the plug is mangled, please stop using and get a new one replaced. Make sure the old one is far away from the printer, so it can avoid someone who does not know the inside story getting damage.
10. Do not use in locations subject to high humidity or dust levels. Excessive humidity and dust may cause equipment damage or fire.
11. Never push objects of any kind into this product though cabinet slots as they may touch dangerous voltage dots or short out parts.
12. Don't remove the printer's out-cover and repair the printer. When needed, call or take it to the professional.
13. To ensure safety, please unplug this product prior to leaving it unused for an extended period. The wall outlet you plan to connect to should be nearby and unobstructed.
14. This product belongs to the impact printer, it produces obviously noise during printing, so we suggest placing this printer in a relatively independent area.
15. When using the printer in room where ventilation is not good or printing a large amount of files, it is suggest that to change the air in time.
16. Unplug this product from the power outlet and leave servicing to qualified service personnel under the following conditions:
 - A. When the power cord or plug is damaged or frayed.
 - B. If liquid has been spilled into the product.
 - C. If the product has been exposed to rain or water.
 - D. If the product does not operate normally when the operating instructions are followed.
 - E. If the product has been dropped or the cabinet has been damaged.
 - F. If the product exhibits a distinct change in performance, it indicates a need for service.

Note: The contents of this manual are subject to change without notice.

*** All parts of the printer can be recycled. When it is abandoned, we can call it back freely. Please contact us when you abandon it.**

Compliance Statements

FCC Compliance Statement for American Users

This equipment has been tested and found to comply with the limits for a Class B digital device, pursuant to Part 15 of the FCC Rules. These limits are designed to provide reasonable protection against harmful interference in a residential installation. This equipment generates, uses, and can radiate radio frequency energy and, if not installed and used in accordance with the instructions, may cause harmful interference to radio communications. However, there is no guarantee that interference will not occur in a particular installation. If this equipment does cause interference to radio or television reception, which can be determined by turning the equipment off and on, the user is encouraged to try to correct the interference by one or more of the following measures:

- Reorient or relocate the receiving antenna.
- Increase the separation between the equipment and receiver.
- Connect the equipment into an outlet on a circuit different from that to which receiver is connected.
- Consult the dealer or an experienced radio/TV technician for help.

CAUTION: Use shielded cables to connect this device to computers.

Any changes or modifications not expressly approved by the grantee of this device could void the user's authority to operate the equipment.

EMI Compliance Statement for Canadian Users

- This Class B Information Technology Equipment complies with Canadian ICES-003.
- Cet Équipement informatique de la classe B est conforme à la norme NMB-003 du Canada.

Warnings, Cautions and Notes

Pay attention to the following promises when using this manual:

Warnings:

Warnings must be followed carefully to avoid bodily injury.

Cautions:

Cautions must be observed to avoid damage to your equipment.

Notes:

Notes contain important information and useful tips on the operation of your printer.

The Guide

First thanks for purchasing this CITIZEN printer. Your printer is a 9-pin 80-column dot matrix printer, offering a wide range of features and multiple functions. It can be widely used in tax, mail, telecom, police, hospital, insurance, finance, stock, customhouse, cabaret, aviation and transport etc.

Printer Features:

- **Install print paper easily**

The installation design makes you operate easily, install paper rapidly and save your time.

- **Tear off function**

This causes tractor paper to be automatically fed to the tear-off position at the edge of the window, for easy tear-off at the perforations after printing. This zero tear-off capability helps eliminate paper wastage.

- **Facility switch between cut-sheet and tractor paper**

Feed the tractor paper back to the installing position through **EJECT/LOAD** key on the control panel, pull the paper select lever to the cut-sheet position, and then insert the cut-sheet from front to print. If you want to use tractor paper again, pull the paper select lever back to the tractor paper position after cut-sheet printing, then press **EJECT/LOAD** key, tractor paper may be fed to the printer again.

- **Eject function**

The function allows the user eject the tractor paper through the facility key on the control panel.

- **Select the data transfer interface automatically**

The printer configures with parallel interface, USB interface or serial interface (according to specific interface standards). Connect the printer to the computer with the correct cables. The printer would switch the correct interface according to the type of data automatically.

- **Emulation**

The printer supports the Epson ESC/PK2 emulation as standard.

- **Break pin compensation function**

User can set the printer to print using the pin which is in good condition to compensate the break pin.

- **Pin switch rotation function**

User can set pins to switch while printing form transverse line in order to improve print head life.

Table of Contents

Important Safety Instructions	i
Compliance Statements.....	ii
The Guide.....	iii
Chapter 1 Preparation.....	1
1.1 Unpacking & Checking	1
1.2 Removing the Protective Materials	1
1.3 Main Parts of the Printer.....	2
1.4 Choosing a Place for the Printer	3
1.5 Installing the Printer.....	3
1.5.1 <i>Installing the Paper Feed Knob</i>	3
1.5.2 <i>Installing the Ribbon Cartridge</i>	4
1.6 Installing the Tractor	6
1.6.1 <i>Installing the Drive Tractor</i>	6
1.7 Connecting the Power Cord	6
1.8 Running the Self-test.....	7
1.9 Connecting the Printer to Your Computer	8
1.9.1 <i>Connecting to the Parallel Cable</i>	9
1.9.2 <i>Connecting to the USB Cable</i>	9
1.9.3 <i>Connecting to the Serial Cable</i>	9
1.10 Installing Driver.....	10
Chapter 2 Control Panel	13
2.1 Indicator Light.....	13
2.2 Key Functions.....	13
2.2.1 <i>In the Tractor Paper Mode</i>	13
2.2.2 <i>In the Cut Sheet Mode</i>	14
2.2.3 <i>Print Speed</i>	14
2.2.4 <i>Micro-Adjust of Printing Home Position and Tear off Position</i>	14
2.2.5 <i>Feed Paper to the Tear off Position</i>	15
2.2.6 <i>Other Functions of the Panel</i>	15
2.3 Paper Select Lever	15
2.4 Paper Feed Knob	15
2.5 Gap Adjust Lever.....	15
Chapter 3 How to Use the Printer.....	17
3.1 Installing the Print Paper	17
3.1.1 <i>Loading Cut Sheets</i>	17
3.1.2 <i>Loading Tractor Paper</i>	19
3.1.3 <i>Loading Multi-ply papers</i>	21
3.2 Changing Printer Settings	21
3.2.1 <i>Setting Printer Parameter Through the Control Panel</i>	21
3.2.2 <i>Online-aptitude Parameter Settings</i>	24

3.3 Printer Setting Descriptions.....	25
3.4 Restore the Default Settings	26
Chapter 4 Problems and Solutions	27
4.1 Power Supply	27
4.2 Printing	27
4.3 Paper Handling.....	29
4.4 Alignment Adjust Mode.....	30
Chapter 5 Printer Maintenance and Technical Service	31
5.1 Printer Cleaning.....	31
Appendix A Specifications	32
A.1 General	32
A.2 Interface Specifications	33
<i>A.2.1 Parallel Interface</i>	<i>33</i>
<i>A.2.2 USB Interface.....</i>	<i>34</i>
<i>A.2.3 Serial Interface.....</i>	<i>34</i>
Appendix B Paper Specification.....	35
B.1 Paper Specification and Printable Area	35
<i>B.1.1 The Notice Relates to Paper.....</i>	<i>35</i>
<i>B.1.2 Useable Paper Types and Guarantee Area</i>	<i>36</i>
<i>B.1.3 Cut sheet.....</i>	<i>36</i>
<i>B.1.4 Tractor Paper.....</i>	<i>38</i>
Appendix C Command Summary	45

Chapter 1 Preparation

1.1 Unpacking & Checking

Check the following items in the package, if any of these items is missing, please contact your dealer.

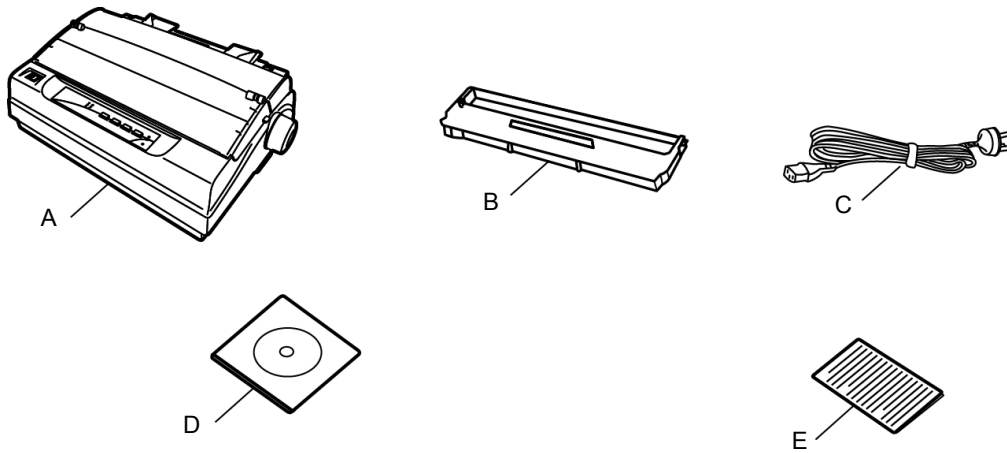

Figure 1-1 Packing list

- A: Printer
- B: Ribbon cartridge (JMR108)
- C: Power cord
- D: Driver CD (Including *user's manual* and driver)
- E: Quick Start Guide

1.2 Removing the Protective Materials

1. Open the packing box, take out the printer, open the window of the printer, and remove the protective materials shown in figure 1-2.
2. Save all the original packing materials so that they can be used when transporting the printer.

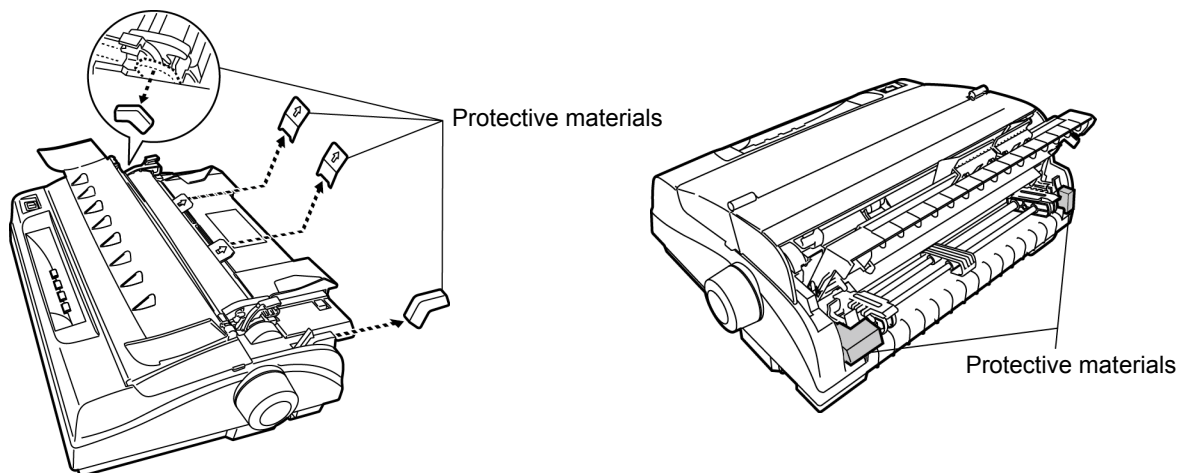

Figure 1-2 Removing protective materials

1.3 Main Parts of the Printer

Figure1-3, Figure1-4 and Figure 1-5 shows the main parts of GSX-190II.

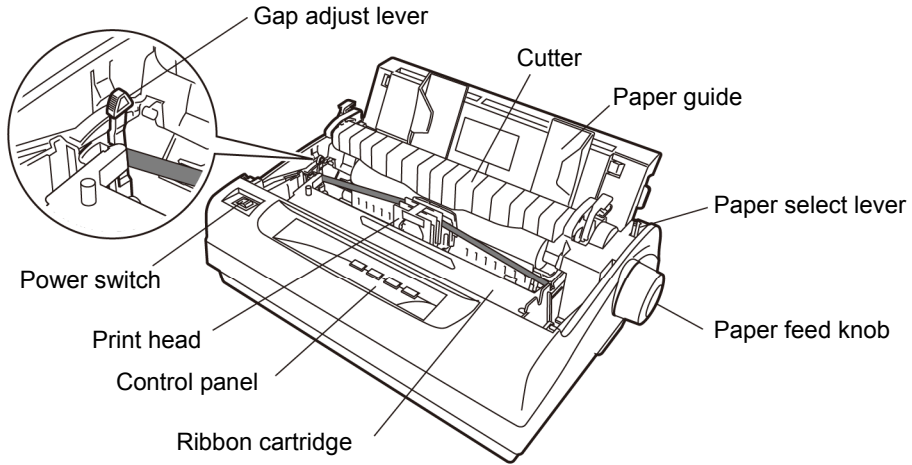

Figure 1-3 Main parts of printer (front view)

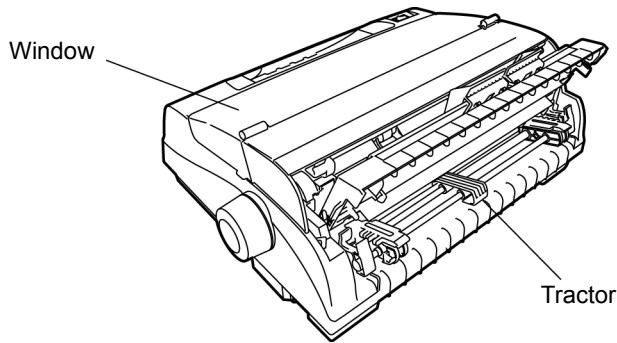

Figure 1-4 Main parts of printer (side view)

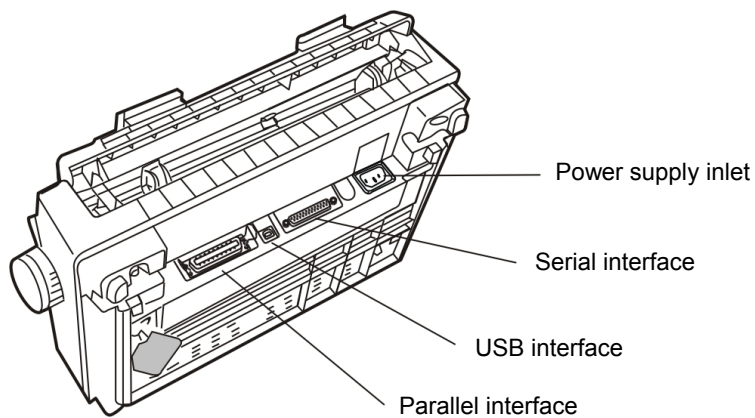

Figure 1-5 Main parts of printer (back view)

Note: According to the specific interface standards.

1.4 Choosing a Place for the Printer

When selecting a place to set up your printer, choose a convenient location that provides the following items:

1. A flat, stable surface.
2. Adequate room around the printer to allow easy operation and maintenance. Make sure it's close enough to the computer for the printer cable to reach, and be sure you can easily unplug the power cord.
3. Moderate environmental conditions. Select a cool, dry area and protect your printer from direct sunlight, excessive heat, moisture, or dust.
4. Appropriate power source. Make sure you use a grounded outlet; do not use an adapter plug. Avoid electrical outlets controlled by timers or wall switches; an interruption in power can wipe out the information in your computer or printer memory.

If you place the printer on a stand, follow these guidelines:

1. Use a stand that supports at least 9 kg (19 lb).
2. Never use a stand that tilts the printer. Always keep it level.
3. Provide enough clearance below the stand and between the printer rack and the legs of the rack so the tractor paper flows smoothly.
4. Place cables so they do not interfere with paper feeding; secure them to a leg of the stand if possible.

1.5 Installing the Printer

Follow the steps in this section to install your printer.

1.5.1 Installing the Paper Feed Knob

1. Insert the paper feed knob into the hole on the right side of the printer.

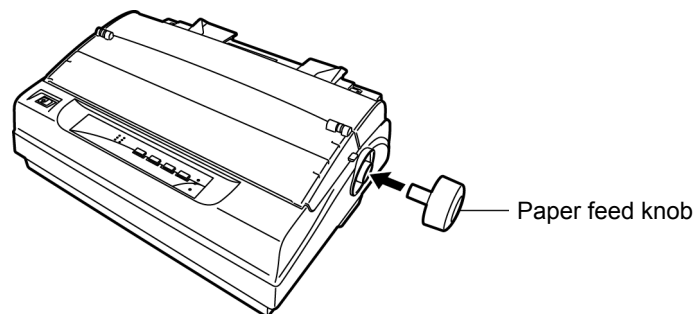

Figure 1-6 Install the paper feed knob

Note: The D shape of knob should be aim at the D shape shaft inside the printer case.

2. Push firmly on the knob until it fits against the printer case.

1.5.2 Installing the Ribbon Cartridge

1. Before installing the ribbon cartridge, make sure the printer is turned off.
2. Remove the window: As shown below, turn the window backwards and then pull up to remove it.

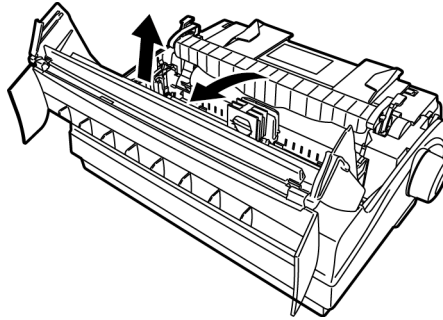

Figure 1-7 Remove the window

3. Remove the cutter: Press the lock sheets on both sides of the cutter, and then pull the cutter upwards as shown below.

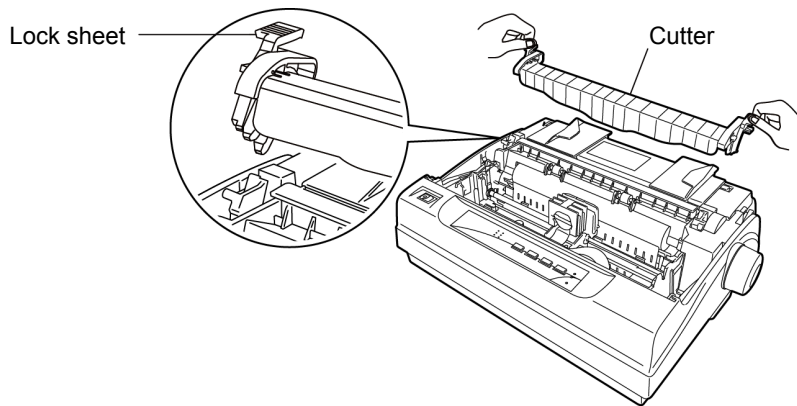

Figure 1-8 Remove the cutter

4. Pull the gap adjust lever to the highest position.
5. Slide the print head to the middle of the printer.

Note: Never move the print head when the printer is on, or else the printer may get damaged. Besides, do not touch the print head if the printer has just been recently used as the print head may be hot.

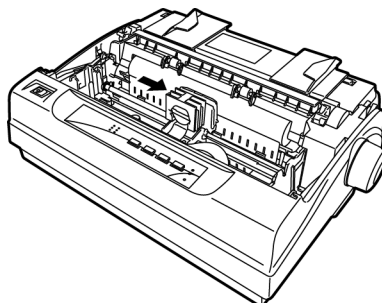

Figure 1-9 Slide the print head to the middle of the printer

6. Hold the ribbon cartridge with the ribbon knob facing upwards. Turn the ribbon knob in the direction of the arrow to remove any slack from the ribbon, so that it is easier to install.

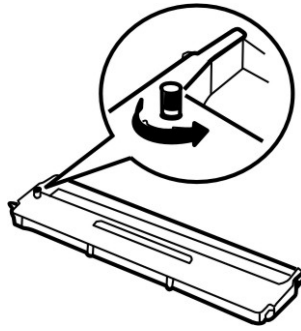

Figure 1-10 Tighten the ribbon

7. Insert the ribbon cartridge into the printer as the following figure shown; then press both sides of the cartridge down firmly to fit the buckles into the printer slots.

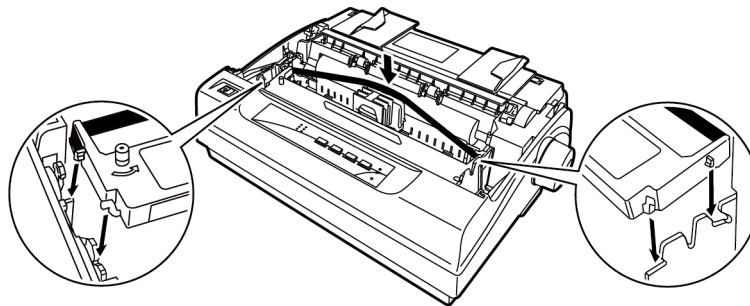

Figure 1-11 Install ribbon cartridge

8. Use hands or other auxiliaries, to guide the ribbon between the print head and metal sheet. Turn the ribbon knob to feed the ribbon into place, it should not be twisted or creased.

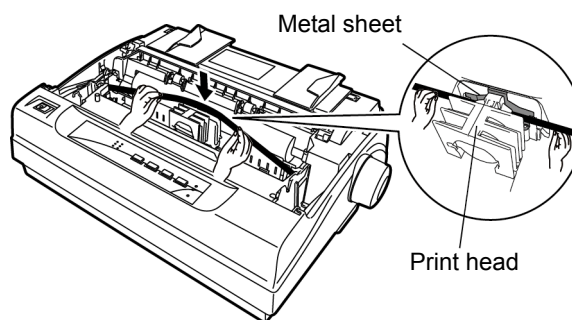

Figure 1-12 Guide the ribbon between the print head and metal patch

9. Slide the print head from side to side several times to make sure it moves smoothly.
10. Pull the gap adjust lever back to the original position. Reinstall and close the window.

- Note:**
1. When your printing becomes faint, you need to replace the ribbon cartridge. Otherwise, the print quality will be affected and the print head may be damaged.
 2. To remove the old ribbon cartridge, first make sure the power is turned off, move the print head to the center of the printer. Then hold both sides of the ribbon cartridge and lift it out of the printer upwards. Install a new one as the above steps.
 3. Please use the original ribbon cartridge only. Manufacturer will not honor warranty when using unauthorized ribbon cartridge.

1.6 Installing the Tractor

1.6.1 Installing the Drive Tractor

Aim the mounting slots on both sides of tractor at the alignment pins which are at the back of printer, press forward till it locks in place. (Shown as figure 1-13)

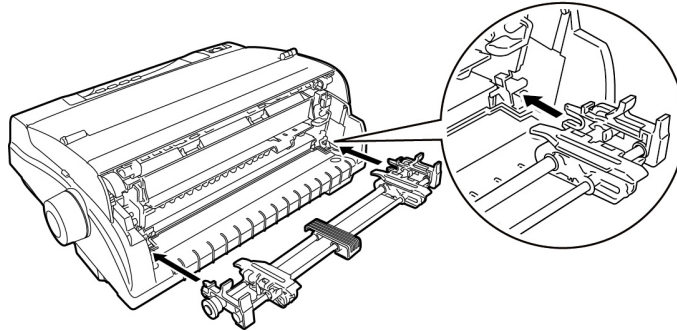

Figure 1-13 Install the drive tractor

1.7 Connecting the Power Cord

1. Make sure the printer is turned off. ("O" mark on the power switch is pressed down.)

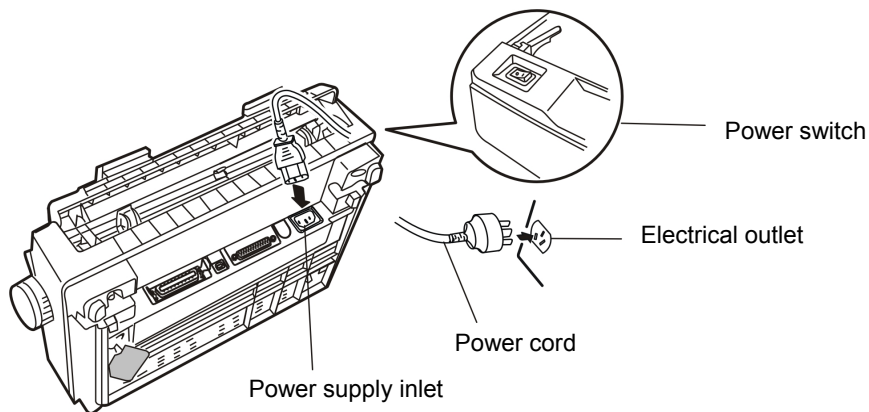

Figure 1-14 Turn off the printer

2. Make sure the voltage required by the printer matches that of your electrical outlet.

3. Plug one end of power cord into the printer power supply inlet.

4. Plug the other end of power cord into a properly grounded electrical outlet.

Note: 1. If the rated voltage and your outlet voltage do not match, contact your dealer for assistance. Do not plug in the power cord.

2. Use the electrical outlet connecting the ground properly.

1.8 Running the Self-test

The built-in self-test function demonstrates that the printer is working properly. You can run the test with either tractor paper or cut sheets; this section describes the easier way of ASCII self-test with cut-sheets.

Note: You should use paper at least 210 mm wide to run the self-test; otherwise, the print head prints directly on the platen.

1. Make sure the printer is turned off and the paper select lever is at the cut sheet position. Raise the paper guide upright.

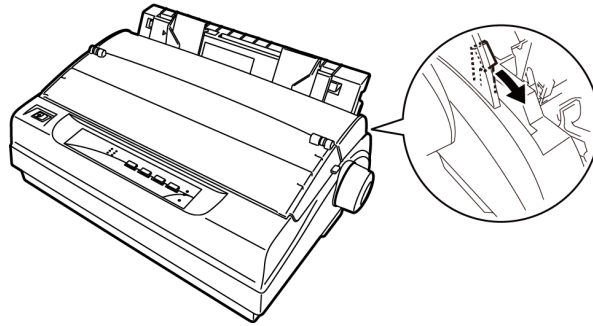

Figure 1-15 Set paper select lever

2. While holding down the **TEAR** key, turn on the printer. At that time, the **POWER** indicator blinks and the **ONLINE** indicator is off, which indicates the printer is out of paper.

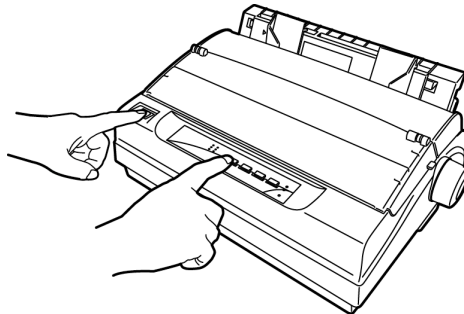

Figure 1-16 Startup self test

3. Slide the left edge guide until it reaches at the triangular guide mark. Next, adjust the right edge guide to match the width of your paper.

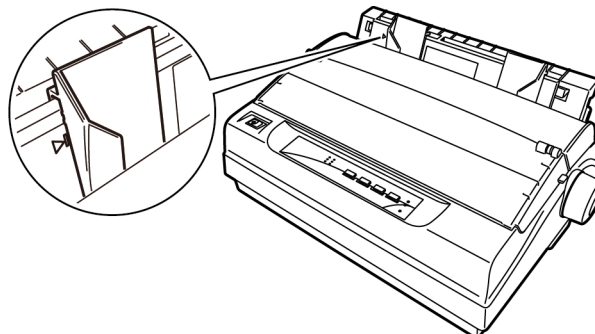

Figure 1-17 Adjust the right and left edge guides

4. Slide a sheet of paper down firmly between the edge guides until it meets resistance. The printer loads the sheet automatically and begins printing when pressing **ONLINE** key.

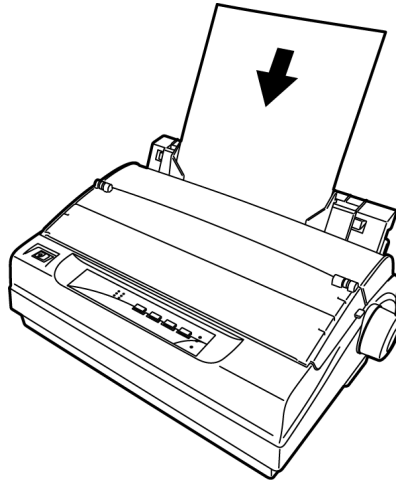

Figure 1-18 Install cut sheets

Warning: Always close the window while the printer is printing.

5. To stop printing temporarily, press the **ONLINE** key.
6. After the printer finishes printing, press **LF/FF** key or **EJECT/LOAD** key to eject cut sheet, and then turn off the printer to exit self test mode.

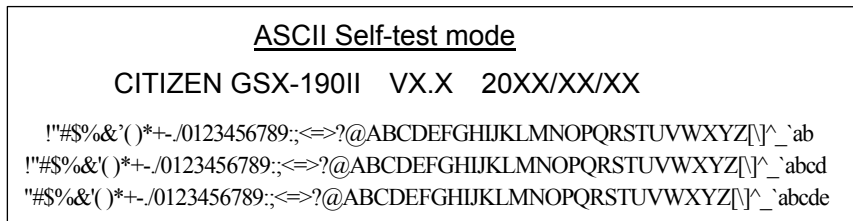

Figure 1-19 ASCII Self-test mode

Note: If the self test does not print satisfactorily, see Chapter 4. If it prints correctly, go on to the next section.

1.9 Connecting the Printer to Your Computer

The printer can be configured with parallel interface, USB interface or serial interface (according to the specific interface standards). Connect the printer to the computer with the correct cables. Before you begin, place the printer upright, as shown below.

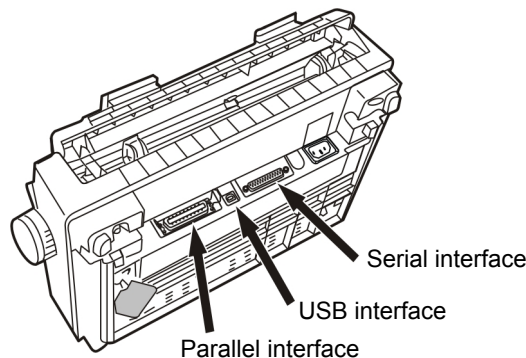

Figure 1-20 Lay the back of printer upwards

Note: Before connecting the parallel cable or the serial cable, please make sure the power of the printer is shut down. Only after tightening the cable may you turn on the power, or it will damage the printer.

1.9.1 Connecting to the Parallel Cable

1. Turn off both the computer and the printer. Plug the parallel cable connector securely into the printer's parallel interface. Squeeze the wire clips together until they lock in place on either side of the connector.

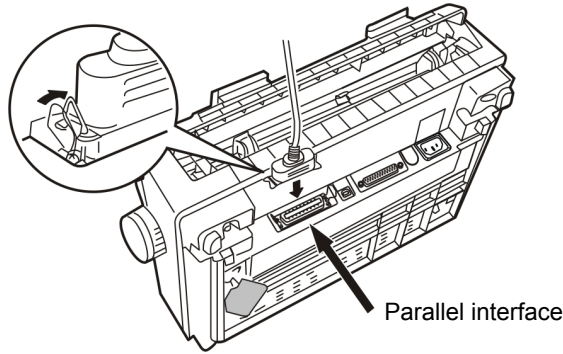

Figure 1-21 Connect to the parallel cable

2. Plug the other end of the cable into the computer's parallel interface. And then tighten the screws on both sides.

1.9.2 Connecting to the USB Cable

1. Plug the A end of the USB cable (flat shape) into the computer's USB interface.
2. Plug the B end of the USB cable (square shape) into the printer's USB interface. (As figure1-22 shown)

Note: Don't impact the plug after connecting to the USB cable.

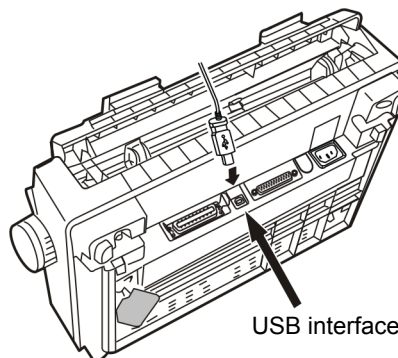

Figure 1-22 Connect to the USB cable

1.9.3 Connecting to the Serial Cable

1. Turn off both the computer and the printer. Plug the serial cable securely into the printer's serial interface. Tighten the screws on both sides of the connector. (As shown in figure1-23)

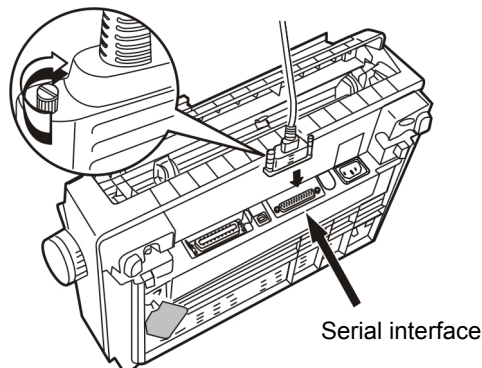

Figure 1-23 Connect to serial cable

2. Plug the other end of the cable into the computer's serial interface; then tighten the screws on both sides of the connector.

1.10 Installing Driver

Please use the cable to connect computer with printer, then turn on the computer and the printer, put the driver CD into the CD-ROM. Install driver by the following ways:

Auto-installing way

Double click the file "Setup.exe" in the driver disc, install driver by the following direct.

Note: Auto-installing way needs the operating system of Windows 2000 or above.

Hand operated installing way

Note: The hand-operated installing ways of serial interface and parallel interface are the same.

1) The installing steps of parallel interface for Windows 2000/XP/Vista are as follows:

1. Click "Start" → "Settings" → Select "Printers".
2. Click "Add Printer", then it pops up a window of "Add Printer Wizard", click "Next", then please read the select guide carefully, such as, select "Local printer" in the "Local or Network Printer" window, then click "next".
3. A window of "Select a Printer Port" pops up, select a usable port. Such as, select "LPT1: (Recommended Printer Port)", click "Next".
4. A window of "Install Printer Software" pops up, click "Have Disk...", click "Next".
5. A window of "Install From Disk" pops up. Please according to the operating system environment, you should select the path as follow: CD-ROM → "Driver" → "WIN2000 (XP-Vista-Win7)", click "Open", then click "OK" to return to the window of "Install Printer Software", select the respective model, click "Next".
6. Follow the guide click "Next" gradually till the installation is finished.

2) The installing steps of parallel interface for Windows 7 are as follows:

1. Click "Start" → "Device and Printers".
2. Click "Add Printer", then it pops up a window of "Add Printer Wizard", click "Next", then please read the select guide carefully, such as, select "Local printer" in the "Local or Network Printer" window, then click "next".
3. A window of "Select a Printer Port" pops up, select a usable port. Such as, select "LPT1: (Recommended Printer Port)", click "Next".
4. A window of "Install Printer Software" pops up, click "Have Disk...", and click "Next".
5. A window of "Install From Disk" pops up. Please according to the operating system environment, such as Windows XP operating system, you should select the path as follow: CD-ROM → "Driver" → "WIN2000 (XP-Vista-Win7)", click "Open", then click "OK" to return to the window of "Install Printer Software", select the respective model, click "Next".
6. Follow the guide click "Next" gradually till the installation is finished.

The USB interface installing steps for Windows 2000/XP/Vista/Win7 are as follows:

The following steps are used Windows XP as example. There are slight differences among different operating systems.

1. Connect the printer to computer with an USB cable and turn on the printer.
2. After the computer find out new hardware and finish searching, pop up a window of "Found New Hardware Wizard", choose "Install from a list or specific location (Advanced)", click "Next".
3. A window of "Found New Hardware Wizard" — "Please choose your search and installation options" pops up, choose "Don't search, I will choose the driver to install", click "Next".
4. A window of "Add Printer Wizard" pops up, click "Have Disk...", click "Browse".
5. A window of "Install From Disk" pops up. Please according to the operating system environment, you should select the path as follow: CD-ROM → "Driver" → "WIN2000 (XP-Vista-Win7)", click "Open", then click "OK" to return to the window of "Add Printer Wizard", select the respective model, click "Next".
6. Follow the guide click "Next" gradually till the installation is finished.

The installing steps for Windows 98 are as follows:

1) The installing steps with a parallel cable or a serial cable:

1. Click "Start" → "Settings" → "Printers".
2. Click "Add Printer", then a window of "Add Printer Wizard" pops up, click "Next", then please read the select guide carefully, such as, select "Local printer" in the "Local or Network Printer" window, then click "Next".
3. A window of "Click the manufacturer and model of your printer" pops up, click "Have Disk...", please click "Browse", select the path as follow: CD-ROM → "Driver" → "WIN98 (WINME)", then click "OK".
4. A window of "Install From Disk" pops up, click "OK", return to a window of "Add Printer", select the respective model, and then click "Next".
5. A window of "Printer port" pops up, select "Available ports", such as, select "LPT1: Printer Port", click "Next", and then show the printer's name. If the system is not installed by other printer driver process, the printer is treated as default printer by the application process of Window98 environment, click "Next". Otherwise according to prompt, choose the printer is default: "Yes", click "Next", choose "Yes-(recommended)", click "Finish". A window of "Printer test page completed" pops up, click "Yes".
6. The printer driver process is installed successfully.

2) The installing steps with an USB cable:

Note: 1. As the system of Windows 98/ME doesn't have integrated USB driver control, please install USB driver before using USB interface printing. Then install USB printer driver.

2. If it has installed the USB driver, please install the USB printer driver directly as the following steps.

USB driver installing steps:

1. Connect an USB cable and turn on the printer.
2. After the computer find out new hardware and finish searching, a window of "Add New Hardware Wizard" pops up, click "Next".
3. A window of "Add New Hardware Wizard" — "Windows operation" pops up, choose "Search the best driver for the device (recommended)", and click "Next".
4. A window of "Search for new drivers" pops up, check "Specify a location", click "Browse", select the path as follows: CD → ROM → "Driver"-"[WIN98 (WINME) \ USB driver]", then click "OK".
5. Return to a window of "Search for new drivers", click "Next"; a window of "Windows driver file search for the device" pops up, click "Next".
6. After the system finishing installing the file automatically, a window of "USB Print Supported" pops up, click "Finish".
7. The printer USB driver process is installed successfully.

USB printer driver installing steps:

1. Click "Start" → "Settings" → "Printers".
2. Click "Add Printer", then a window of "Add Printer Wizard" pops up, click "Next".
3. A window of "Click the manufacturer and model of your printer" pops up, click "Have Disk...", please click "Browse", select the path as follow: CD-ROM → "Driver" → "WIN98 (WINME)", and then click "OK".
4. A window of "Install From Disk" pops up, click "OK", return to a window of "Add Printer", then click "Next".
5. A window of "Printer port" pops up, select "Available ports", select "JMUSB", click "Next", and then show the printer's name. If the system is not installed by other printer driver process, the printer is treated as default printer by the application process of Window98 environment, click "Next". Otherwise according to prompt, choose the printer is default: "Yes", click "Next" choose "Yes-(recommended)", click "Finish". A window of "Printer test page completed" pops up, click "Yes".
6. The printer driver process is installed successfully.

Chapter 2 Control Panel

You can use the four keys on the control panel to operate your printer, such as line feed, form feed, load paper, eject paper or set print speed. The indicator lights on the control panel show the current print speed.

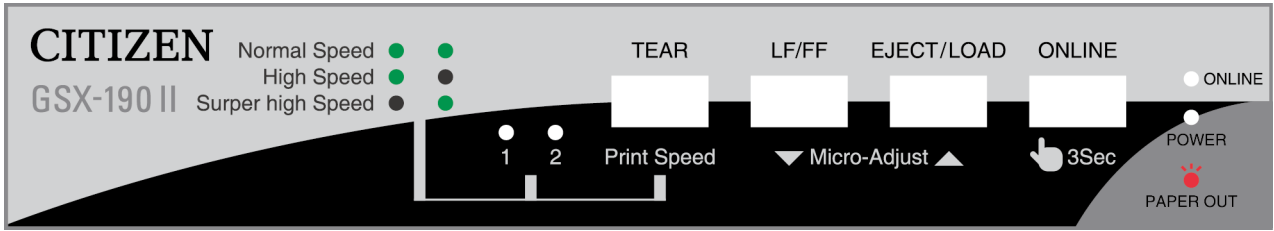

Figure 2-1 Control panel

2.1 Indicator Light

Indicator	OFF	ON	BLINK
ONLINE (Green)	Offline	Online	Micro-Adjust
POWER (Red)	Turn off	Turn on	Paper out or malfunction occurs
Indicator 1, 2	Indicate the current printing speed		

2.2 Key Functions

2.2.1 In the Tractor Paper Mode

TEAR

1. In the offline mode, if the paper is at the print position, press **TEAR** key once and the printer feeds paper to the tear off position.
2. In the offline mode, if the paper is at the tear off position, press **TEAR** key once and the printer ejects paper to the next page or the printing home position of the current page.

LF/FF

In the offline mode, if the paper is at the print position, press the **LF/FF** key once (less than 0.5 second), the printer will feed the paper one line base on current line spacing. Alternatively, hold the **LF/FF** key down, the printer will load tractor paper one page continuously.

EJECT/LOAD

1. When the paper is at the ready position, press **EJECT/LOAD** key once, the paper will be fed into the printing home position automatically.
2. When the paper is at the printing home position, press **EJECT/LOAD** key in the offline mode, the paper will return the ready position.
3. When the paper is at the general print position (not the printing home position), press **EJECT/LOAD** key once in offline mode less than 0.5 seconds, the paper is ejected one line. Alternatively, hold the **EJECT/LOAD** key down, the printer will eject one page when the ejectable length is longer than one page. If the paper ejectable length is less than one page, the paper will go back to the ready position.
4. When the paper is at the tear off position, press **EJECT/LOAD** key once, the printer will eject the one page automatically.

ONLINE

1. If the printer has loaded paper in the offline mode, press the key to enter **ONLINE** mode, the **ONLINE** indicator is on and the printer available to print now.

Press this key in the online mode, the printer is offline, **ONLINE** indicator is off and the printer is unavailable to print.

- If the paper is at the tear off position in the offline mode, press **ONLINE** key, the printer will go back to the printing home position of the current page or the next page.

2.2.2 In the Cut Sheet Mode

LF/FF

If the paper is at the print position in the offline mode, press the **LF/FF** key once (less than 0.5 second), the printer will feed the paper one line base on current line spacing set. Alternatively, hold the **LF/FF** key down, the printer will eject the paper until the cut sheet is entirely ejected.

EJECT/LOAD

If the paper is at the print position, press the **EJECT/LOAD** key once in the offline mode, the paper will be entirely ejected from the printer.

ONLINE

If the printer has loaded paper in the offline mode, press **ONLINE** key to enter **ONLINE** mode, the **ONLINE** indicator is on and the printer is available to print.

Press this key in the online mode, the printer is offline, **ONLINE** indicator is off and the printer is unavailable to print.

2.2.3 Print Speed

- When printer is in the offline mode, holding the **ONLINE** key down for about 3 seconds, the **ONLINE** indicator blinks with a beep.
- The printer is in the alternate mode. Press the **PRINT SPEED** key to change the print mode among Normal Speed mode, High Speed mode and Super High Speed mode. The combination ON (●) and OFF (●) of the indicator lights to show the printer current print speed.

Print speed	Indicator	
	1	2
Normal	●	●
High speed	●	●
Super high speed	●	●

- Press the **ONLINE** key again save the value and quit the alternate mode.

2.2.4 Micro-Adjust of Printing Home Position and Tear off Position

- After turning on the printer, install tractor paper properly using drive tractor and feed paper to the printing home position.
- Hold the **ONLINE** key down over 3 seconds in the offline mode till the **ONLINE** indicator blinks with a beep.
- Press ▲ or ▼ key to feed paper upwards or eject paper downwards.
- Press the **ONLINE** key again to save the setting and quit the alternate mode after finishing adjusting. Before adjusting again, the printing home position or the tear off position will be effective all the time. After the tear off position is adjusted, press **ONLINE** key to make the printer online and you can send commands to print. Only after the printing home position is adjusted, the printer ejects all the paper and feeds paper again, does it print.

The printing home position adjusting methods of cut sheet and tractor paper are the same.

Note: The adjustable range of printing home position is from -18/60 inch to +60/60 inch (base on default position set by the factory).

The adjustable range of tear off position is from -15/60 inch to +15/60 inch (base on default position set by the factory).

2.2.5 Feed Paper to the Tear off Position

1. Turn on the printer, and then hold the **ONLINE** key down for about 3 seconds in the offline mode till the **ONLINE** indicator blinks with a beep.
2. Hold the **TEAR** key down for about 3 seconds to switch the function of automatically feeding paper to the tear off position **ON** or **OFF**.

2.2.6 Other Functions of the Panel

Turn on the printer while holding some buttons, and then the printer will enter the special mode.

Key	Function
ONLINE + POWER	Enter printer setting mode to change the printer default setting. Long press EJECT/LOAD key in online mode to enter menu setup mode.
EJECT/LOAD + POWER	Chinese self-test mode
LF/FF + POWER	Print pin test mode
TEAR + POWER	English self-test mode
TEAR + LF/FF + POWER	Hex dump mode

2.3 Paper Select Lever

Use the paper select lever to specify the printing mode of cut sheet or tractor paper. If you use cut sheet to print, please pull the paper select lever to cut sheet position; if you use tractor paper to print, pull the paper select lever to tractor paper position.

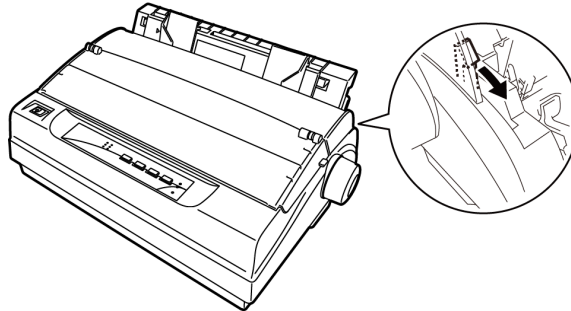

Figure 2-2 Paper select lever

2.4 Paper Feed Knob

The paper feed knob is used to load or eject paper manually. In general, it's better not to use it.

2.5 Gap Adjust Lever

Set the gap adjust lever to proper position according to the thickness of your printing materials. It is factory-set for standard office paper.

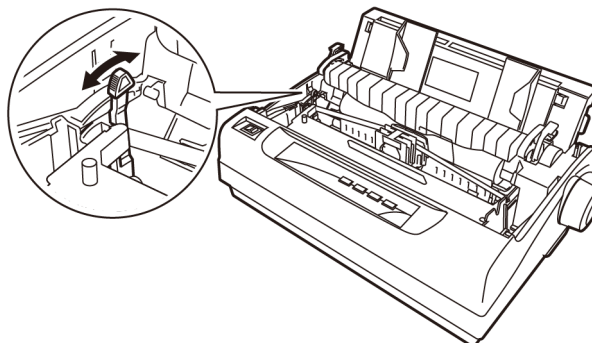

Figure 2-3 Gap adjust lever

Use the table below to select the appropriate paper thickness.

Copies (including original)		Lever position
(Reserved)		-1
Standard paper (cut sheet or tractor paper)		0
Multi-ply paper	2-ply	1
	3-ply	2
	4-ply	3
(Reserved)		6

Chapter 3 How to Use the Printer

Here are the steps of using printer:

1. Assemble the printer as the chapter 1, connect the printer to your computer and install the driver correctly.
2. Load the correct type of paper.
3. Set the printer if necessary.
4. Send the print command to the printer to print.

3.1 Installing the Print Paper

In addition to printing on cut sheets and tractor papers, your printer can also print on a wide variety of paper types, including multi-part forms.

Caution: When printing on multi-ply paper, as it is thicker than general paper, it needs the bigger print force, so printing past or at the edge of these papers may damage the print head.

Please make sure the printing contents are all within the printable area while printing. The correlative printable area, see the Appendix.A for reference.

3.1.1 Loading Cut Sheets

1. Make sure the printer is powered off, and open the window of the printer, refers to chapter 2.5 Gap adjust lever of this manual according to the paper type.

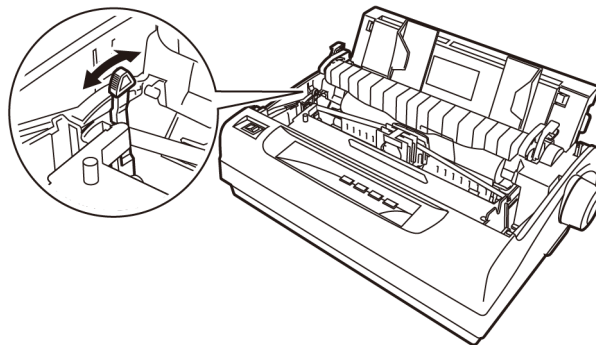

Figure 3-1 Adjust gap adjust lever

2. Close the window, and set paper select lever toward the cut sheet position.

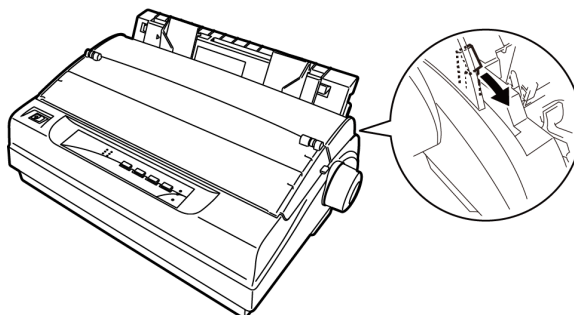

Figure 3-2 Adjust paper select lever

3. Raise the paper guide upright, and then turn on the printer.

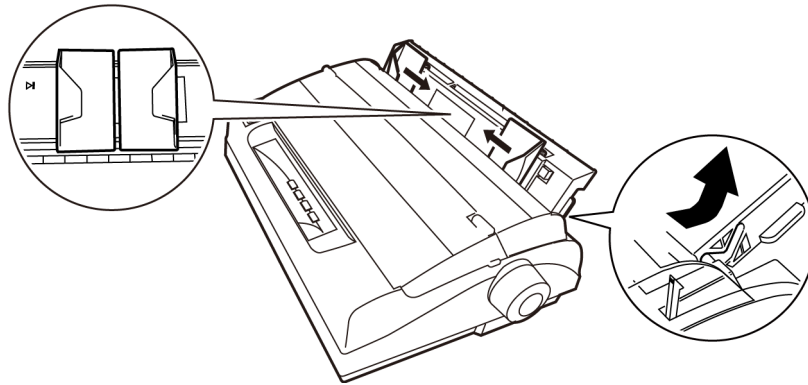

Figure 3-3 Raise the paper guide upright

4. Slide the left edge guide until it reaches the triangular guide mark. Next, adjust the right edge guide to match the width of your paper. (As shown in figure 3-4)

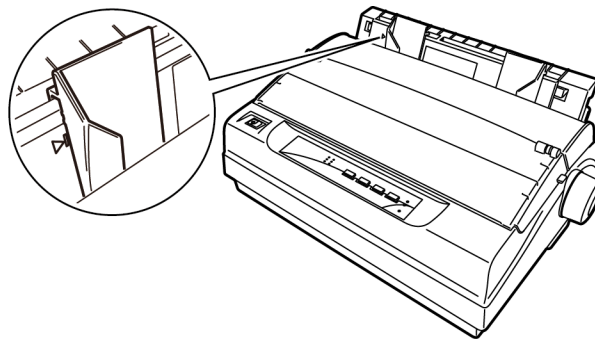

Figure 3-4 Adjust the paper guide

5. Slide a sheet of paper down firmly between the edge guides until it meets resistance. The printer loads the sheet automatically. (As shown below)

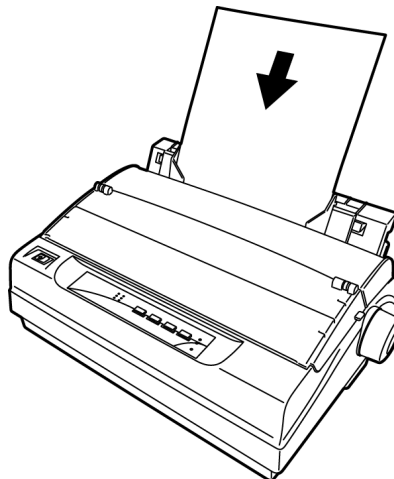

Figure 3-5 Insert cut sheet

6. Adjust the printing home position according to the steps in chapter 2.2.4 if necessary.

Note: Don't feed the paper with Paper feed knob, or it will influence the paper not feeding properly.

3.1.2 Loading Tractor Paper

For easy to switch between printing on cut sheets and tractor paper, or easy to tear off tractor paper sheet by sheet, you should use the tractor in push position. The printer comes with the tractor installed in this position at the factory settings.

Using drive tractor:

1. Make sure the printer is turned off. Remove the paper guide and place the paper select lever in the tractor paper position. Open the printer window, and then adjust the gap adjust lever according to paper type.

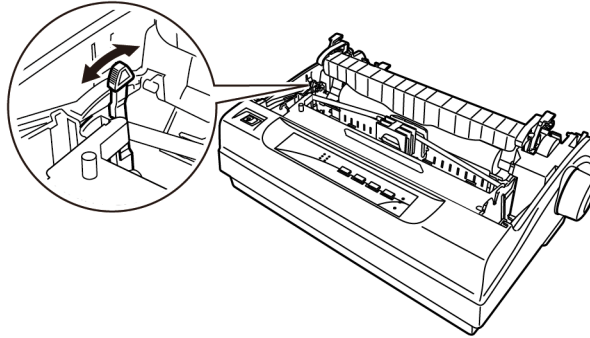

Figure 3-6 Adjust gap adjust lever

2. Make sure the tractor is installed correctly (refer to chapter 1).
3. Pull the sprocket lock lever of the drive tractor upwards to release the sprocket. (As shown below)

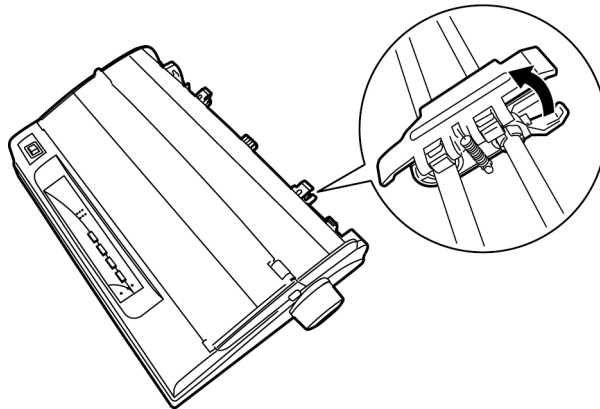

Figure 3-7 Release the sprocket

4. Slide the left sprocket referring to the scale on the printer. The printer prints to the right of the 0 scale. Push the left sprocket lock lever to lock the left sprocket in place. Then slide the right sprocket to match the width of your paper, but do not lock it. Move the paper support so it is midway between the tractors. (Shown as figure 3-8)

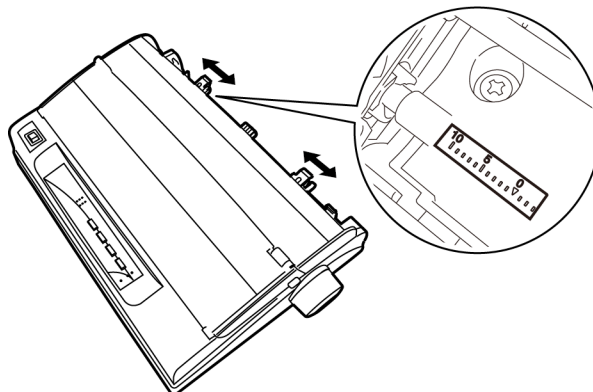

Figure 3-8 Adjust the position of the sprockets

5. Make sure your paper has a clean, straight leading edge. Open the sprocket covers. Fit the first holes of the paper over the sprocket pins and then close the sprocket covers. Slide the right sprocket unit to remove any slack in the paper and lock it in place. Now the paper is in the ready position.

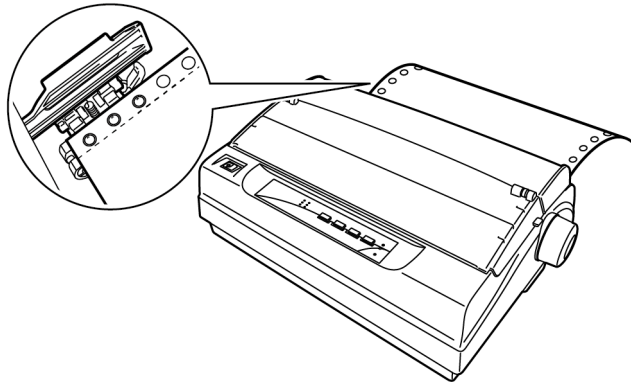

Figure 3-9 Load the tractor paper in the tractor

Note: Only to clean the paper jams when the printer is turned off, can use the paper feed knob on the right side of the printer. Otherwise, you may damage the printer or change the printing home position.

6. Hold the paper guide horizontally and install it according to the follow figure, then block it in the direction shown by the arrow.

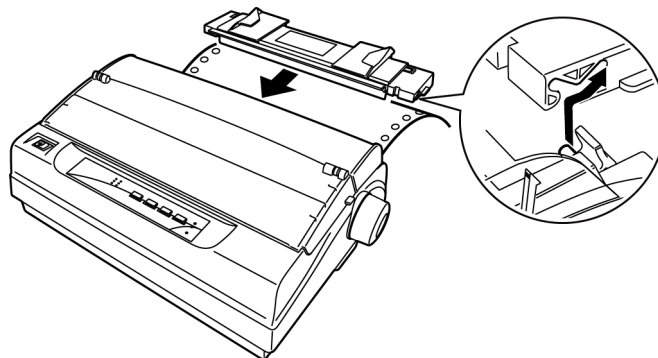

Figure 3-10 Install paper guide

7. Slide the right and left edge guides of the paper guide to make them stop at the stopper located on the paper guide. (As shown figure 3-11)

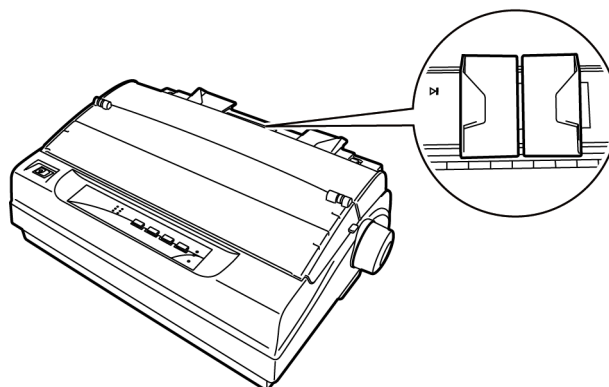

Figure 3-11 Adjust the position of paper guide

8. Make sure the window is closed. Turn on the printer, and press **EJECT/LOAD** key to feed paper. You can adjust the printing home position according to chapter 2.2.4. When the printer receives data, it begins printing automatically.

Note: Do not use the knob to adjust the printing home position due to the micro-range is limited. When the adjustment exceeds the up-limit or down-limit, the beeper beeps and the position can not be adjusted for a further time. The position is in effect before next adjustment. (The margin set in the software can cover this adjustment, so you had better adjust the printing home position with the software.)

9. When you finish printing (the printer receives no data for several seconds) the printer feeds the perforation of the tractor paper to the edge of the window so that you can tear off the last sheet.

Note: Set the function of feeding paper to tear off position in the Print Setting mode on. Otherwise, the printer does not feed the perforation to the edge of the window.

10. If the perforation and the edge of the window do not match, you should adjust the tear off position following the steps in chapter 2.2.4 until they are matched, and then tear down the paper having been printed.

When you send print data again, the paper automatically feeds back to the printing home position and ready to print.

How to switch tractor paper to cut sheet

Firstly, tear down the tractor paper having been printed, then hold **EJECT/LOAD** key to eject the paper in the offline mode. Pull the paper select lever to the cut sheet position, and load the cut sheet according to chapter 3.1.1.

Caution: Make sure tractor paper having been printed is tore off before ejecting the paper, as too many pages to be ejected may cause paper jammed.

3.1.3 Loading Multi-ply papers

The installing ways of multi-ply papers and tractor paper are the same. Just pay attention to the following tips when installing:

1. Must refer to the figure below to lift up the paper guide, otherwise, it may cause paper jam during printing.

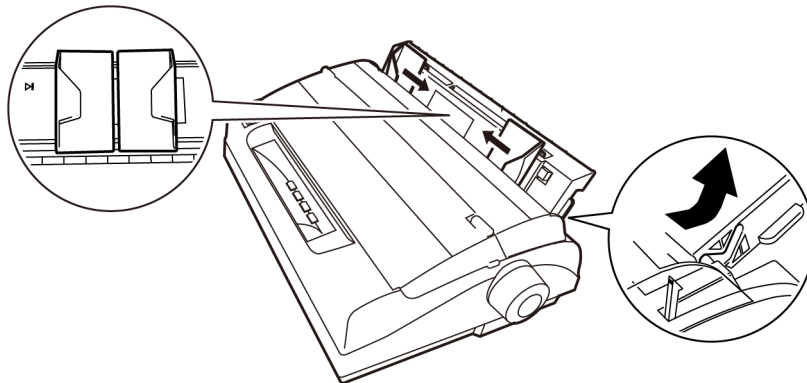

Figure 3-12 Lift up paper guide

2. Never load multi-ply papers joined by metal staples, tape, or continuous gluing.
3. Avoid printing beyond the printable area of multi-ply papers, or it may damage the print head (see Appendix for details).

3.2 Changing Printer Settings

3.2.1 Setting Printer Parameter Through the Control Panel

1. Press the **ONLINE** key on the control panel while turning on the printer. The print head returns with the printer beeping once. It is paper out if the **ONLINE** indicator is off and the **Power** indicator blinks.
2. Set the paper select lever to the proper position. (If in cut sheet mode, the paper select lever should

in the cut sheet position, otherwise, it should in the tractor paper mode.)

- After loading paper, in cut sheet mode, the printer would print out the current setting and facility operation guide of control panel automatically. In tractor mode, after installing the paper to the drive tractor, once you press **EJECT/LOAD** key, the printer would load paper to printing home position and then print out the current setting and the facility operation guide of control panel.

CITIZEN GSX-190II

Current Setting Report

SYSTEM SETUP

EMULATION	<u>EPSON</u>	IBM
LANGUAGE	<u>ENGLISH</u>	CHINESE
CHAR. MODE	<u>ASCII</u>	CHINA

CHARACTER

FONT	<u>ROMAN</u>	SANS SER					
ENG PITCH	<u>10 CPI</u>	12 CPI	15 CPI	17.1 CPI	PROPORTIONAL		
CHI PITCH	<u>6.7 CPI</u>	7.5 CPI					
INTL CHAR SET	<u>U. S. A.</u>	FRANCE	GERMANY	U.K.	DENMARK1	SWEDEN	ITALY
	SPAIN 1	JAPAN	NORWAY	DENMARK2	SPAIN 2	LATIN AM	KOREA
	LEGAL	HOLAND	TURKEY				
CHARACTER SET	ITALICS	<u>GRAPHICS</u>					
IBM CHAR TBL	<u>SET 1</u>	SET 2					
CODE PAGE	<u>U.S.A.</u>	MULTI	PORTUGAL	CANADA	NORWAY	ICELAND	BRASCII
	ABICOMP	ROMAN 8	ISO LTN1	PC858	ISO LTN9	ARAB NLS	WIN 1256
	TURKEY	WIN LAT1	CYRILLIC	RUSSIAN	THAI	VIETNAM	

PAGE LAYOUT

LINE SPACING	<u>6 LPI</u>	8 LPI					
FORM LENGTH	3 INCH	3.5 INCH	11/3 INCH	4 INCH	5 INCH	5.5 INCH	6 INCH
	7 INCH	8.5 INCH	<u>LETTER</u>	A4	12 INCH		
FORM LOCK	<u>OFF</u>	ON					
PAGE SKIP	<u>OFF</u>	ON					
COMPRESS PRINT	<u>NORMAL</u>	75%	50%				

PRINT SETUP

PRINT DIR	BI-DIR	UNI-DIR	<u>AUTO</u>
PRT-SPEED	NOR-SPEED	<u>HI-SPEED</u>	SUP-SPEED
AUTO LF	<u>OFF</u>	ON	
TEAR OFF	<u>OFF</u>	ON	
TEAR POS	<u>TEARER</u>	HEAD TOP	
PIN SWITCH	<u>OFF</u>	ON	
IMPACT MODE	<u>NORMAL</u>	COPY 1	COPY 2

SERIAL 1/F

BAUD RATE	19200 BPS	<u>9600 BPS</u>	4800 BPS	2400 BPS	1200 BPS
PARITY	<u>NONE</u>	ODD	EVEN		
DATA BIT	<u>8 BIT</u>	7 BIT			
STOP BIT	<u>1 BIT</u>	2 BIT			
PROTOCOL	XON/XOFF	<u>DTR</u>			

Please press the **ONLINE** key, ensure the online light is on, then hold down the **EJECT/LOAD** key about 3 seconds to enter Menu Setup Mode.

Note: It's suggest using the paper which is not smaller than 8*11inch (width*length).

Figure 3-13 Print out the current menu setting

Note: 1. The current settings are underlined.

2. When you select compress printing in the setup menu, high speed printing is invalid.

1. The printer is in online mode, holding the **EJECT/LOAD** key down for 3 seconds.
 - The power indicator and online indicator blink twice simultaneously which indicates that the printer enters the menu setup mode.
 - The title and main menu are printed out firstly (as the following figure shown), the default settings are underlined. Print head stays under the current default item.

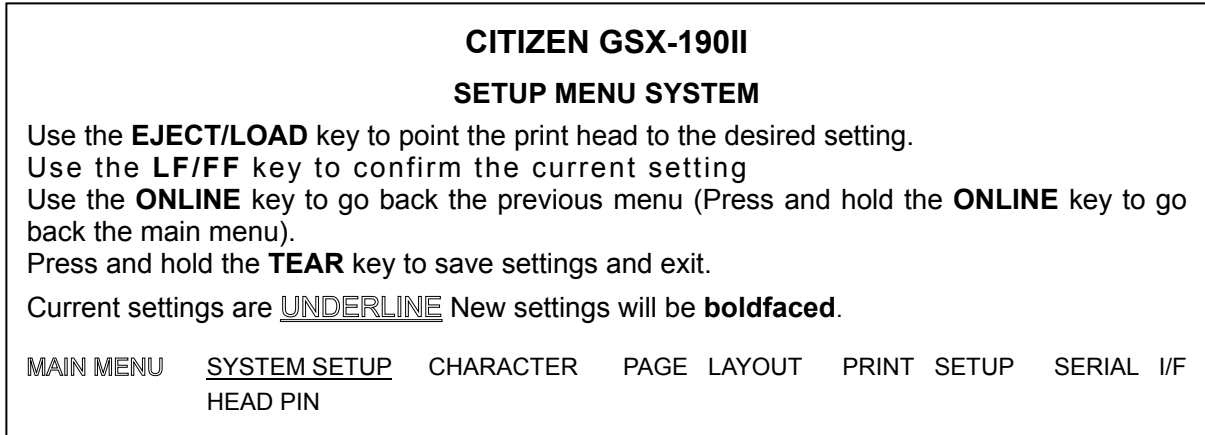

Figure 3-14 Menu setup mode

2. Using the following keys to modify the menu setting:

EJECT/LOAD Select the menu option or menu setting value.

LF/FF Enter into submenu or confirm menu setting value.

Note: Newly setting option would be shown in **FILLED**.

ONLINE Return to upper menu (Hold on pressing **ONLINE** key would return to main menu directly).

TEAR Save and exit the menu setup mode.

3. Giving up the settings just modified, just turn off the printer directly. If you need to save the newly setting, long press **TEAR** key to save and exit the menu setup mode.

4. Turn off and restart the printer, newly settings are in operation.

3.2.2 Online-aptitude Parameter Settings

GSX-190II supports the function of online-aptitude parameter settings, which can be set in the PC with the driver installed in.

The concrete setting steps are shown as follows:

1. Make sure that the host and the printer are connected with a cable and both the host and the printer are turned on, the printer should be in normal working condition as well.
2. Click “Start” → “Settings” → “Printers”.
3. Right click “CITIZEN GSX-190II” in the “Printers”, select “Properties”.
4. Click “Printer Settings” in the property page.

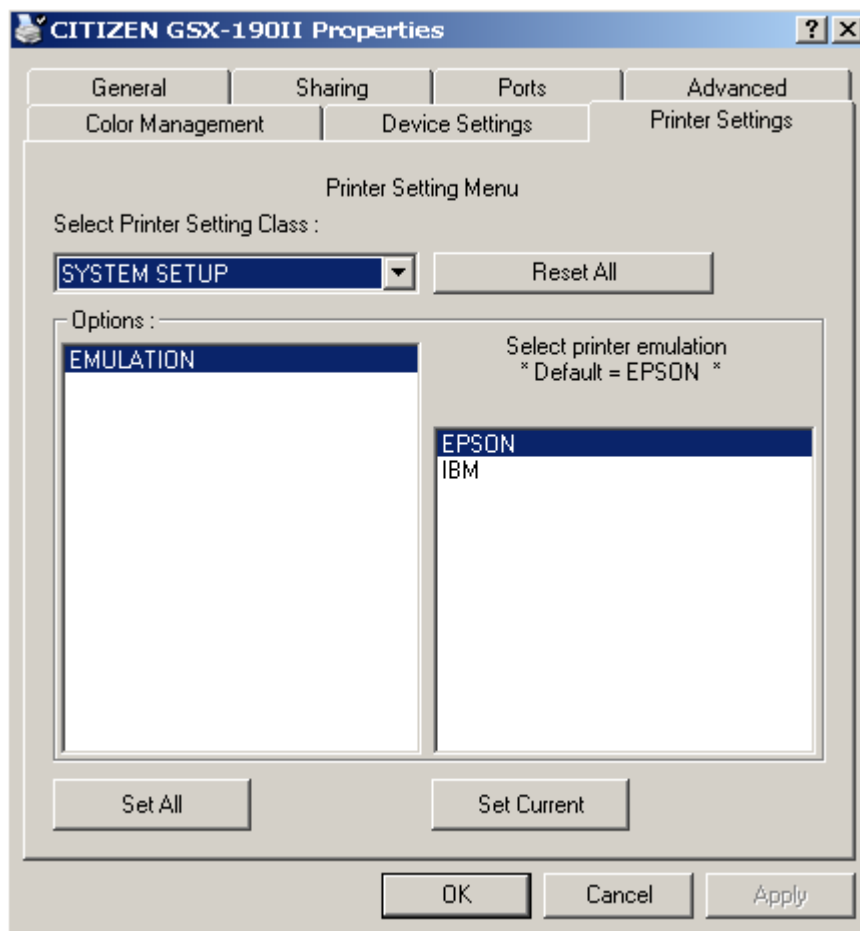

5. The setting way is corresponding with that of printer menu system. In the “Printer Settings” layout, select the first class menu in the combobox of “Select Printer Setting Class”, select the second menu in the “Options” and set the item in the current parameters list.
6. Click the key “Reset All” to reset all the parameters to be the driver’s default, but not change the printer’s settings.
7. When setting the parameters: you can click “Set Current” to save the current settings after setting each item, or you can also click “Set All” after setting all parameters. After clicking “Set All” or “Set Current”, the parameter’s instruction will be sent to the printer.
8. The printer’s parameter settings are changed at once after receiving the instruction and the printer does not need to restart.
9. After finishing settings, click “OK”, exit the “Properties” window.

3.3 Printer Setting Descriptions

This section describes all the settings available in the Menu Setup Mode.

Options	Description
SYSTEM SETUP	
EMULATION	Specify printer's control commands.
LANGUAGE	Specify the printer menu language as English or Chinese.
CHAR. MODE	Select ASCII or Chinese character mode to print when printer receives character printing task.
CHARACTER	
FONT	Specify a kind of ASCII fonts to print when printer receives character printing task. If the print data with font instruction, printer gives priority to print data instruction. (Only valid when CHARACTER MODE is choosing ASCII)
ENG PITCH	Specify the ASCII character spacing in characters per inch (cpi).
CHI PITCH	Specify the Chinese character spacing in characters per inch (cpi).
INTL CHAR SET	Specify the printer internal character set according to different using circumstances of international characters.
CHARACTER SET	Specify character set as Italic Character or Graphic Character.
IBM CHAR TBL	Select IBM character table 1, which the position from 80H to 90H of character table are control codes.
CODE PAGE	Select the code page according to different national characters use circumstances.
PAGE LAYOUT	
LINE SPACING	Specify the line spacing in lines per inch (lpi). If the print data with vertical pitch instruction, printer would give priority to print data instruction.
FORM LENGTH	Specify the page length of the form, for both cut sheet and continuous paper. Printer feeds to next page according to the specified page length. If the print data with page length instruction, printer would give priority to print data instruction.
FORM LOCK	After selecting this function on, printer would lock the page length setting. Printer feeds to next page according to the current setting parameter and would not affected by the page length instruction of the print data.
PAGE SKIP	After selecting this function on, printer would leave one inch (25.4mm) margin at the perforation of the tractor paper automatically. If the print data with page margin instruction, printer would give priority to print data instruction.
COMPRESS PRINT	After selecting this function on, printer would print out transverse compressed content according to the specified percentage in normal speed. When auto-compress mode is selected, printer would detect paper width automatically and choose the proper percentage to print.
PRINT SETUP	
PRINT DIR	Select the printing direction of the print head: unidirectional, bidirectional or selected via software.
PRT-SPEED	Specify the print speed of printer. Printing resolution is lower while print speed is higher.
AUTO LF	If this function is on, printer would advance the paper one line automatically after receiving every carriage return instruction.
TEAR OFF	Select the function of feeding the paper to tear off position ON or OFF in tractor paper mode. After selecting this function on, if the printer receives FF command for a period of time, but receives no printing data, printer would feed the page bottom to tear off position automatically.

TEAR POS	After selecting this function on, when the printer has finished printing, paper would be fed to the set tear off position automatically, and you should tear off the paper manually.
PIN SWITCH	After selecting this function on, printer would switch different pins to print table line automatically.
IMPACT MODE	According to customer's printing requirement, select the printing capability.
SERIAL 1/F	
BAUD RATE	Specify the printer serial data transfer rate.
PARITY	Specify the parity bit for serial data transfer.
DATA BIT	Specify the serial data bits.
STOP BIT	Specify the serial data transfer stop bit.
PROTOCOL	Specify the protocol of printer serial data transfer as software control (XON/XOFF) or hardware control (DTR).

3.4 Restore the Default Settings

1. Hold on **TEAR**, **EJECT/LOAD** and **LF/FF** keys on the control panel at the same time while turning on the printer. The indicators of the **POWER** and **ONLINE** on the control panel blink 3 times respectively at the same time and the printer makes two beeps to confirm that the printer's factory settings have been restored.
2. Release the keys and switch the printer off and on again.
3. After these steps, the printer's factory settings work.

Chapter 4 Problems and Solutions

Most problems you may encounter while operating your printer, herein, have simple solutions for those problems.

You can check the operation of your printer using the self test. See "Running the Self-test" on chapter 1.8. If the self test works properly, the problem probably lies in the computer, the software, or the interface cable. If the self test does not work, contact your dealer or qualified service person for assistance.

Note: Press EJECT/LOAD key while turning on the printer, you can run the Chinese self test.

Press TEAR key while turning on the printer, you can run the ASCII self test.

Note: If you are an experienced user or a programmer, you can print a hexadecimal dump to isolate communication problems between the printer and computer. To print a hex dump, firstly to install paper and turn off the printer. Next, hold down the LF/FF and TEAR keys at the same time while you turning on the printer. Then send data from your computer. The printer prints all the codes it receives in hexadecimal format.

4.1 Power Supply

Power is not being supplied normally.

Phenomenon 1: The lights on the control panel do not go on, and the printer has no action.

Solutions:

1. Check that the power cord is properly plugged into the electrical outlet.
2. If the electrical outlet is controlled by an outside switch or automatic timer, use another outlet.
3. Plug another electrical device, such as a lamp, into the outlet to determine whether the outlet is operating properly.

Phenomenon 2: The lights come on briefly and then go off. The lights stay off even when the power is turned on again.

Solutions: Check whether the printer's rating voltage is matched with the power cord. If not, unplug the power cord immediately and contact your dealer or a specified CITIZEN service center for advice. Do not plug the power cord to the electrical outlet again.

4.2 Printing

The printer does not print.

Phenomenon 1: The Online light is on but nothing is printed.

Solutions:

1. Check that the Driver is installed properly for your printer, as described on chapter 1.10. Check the driver's printer settings.
2. Check both ends of the interface cable. Make sure the cable meets both the printer and computer specifications.

Phenomenon 2: The Online indicator is off and the ONLINE indicator blinks with the printer beeping once.

Solutions: The printer may be out of paper. Load paper in the printer.

Phenomenon 3: The printer sounds like it is printing, but nothing is printed.

Solutions:

1. The ribbon cartridge may not be installed properly. See chapter 1.5.2.
2. The ribbon may be worn out. Replace the ribbon.

3. The gap adjust lever may be too high. If so, move it to the corresponding thickness position with the paper.

Phenomenon 4: The printer makes a strange noise while printing.

Solutions:

1. Turn off the printer and check for a paper jam, a ribbon jam, or other problems.

Phenomenon 5: The beeper sounds several times and the ONLINE indicator is off.

Solutions:

1. Switch off the printer and power on again.
2. If the **ONLINE** indicator stays off, check for a paper jam or ribbon jam. If it does, turn the printer off and clear the jam.
3. If an error occurs when you switch between cut sheets and tractor paper, make sure the paper select lever is in the correct position.
4. If the printer still does not work correctly, turn off the printer and contact your dealer or a specified CITIZEN service center.

● **The print is faint or uneven**

Phenomenon 1: Printed characters have parts missing at the top or bottom.

Solutions: The ribbon cartridge may not be installed properly. See section 1.5.2.

Phenomenon 2: The printout is faint.

Solutions: The ribbon may be worn out. Replace the ribbon as described on chapter 1.5.2.

● **The ribbon can not move smoothly.**

Solutions: The ribbon may be worn out. Replace the ribbon as described on chapter 1.5.2.

● **Dots are missing in printed characters or graphics**

Phenomenon 1: A line of dots are missing in the printout.

Solutions: The print head may be damaged. Stop printing and contact your dealer or a specified CITIZEN service center to have the print head replaced.

Phenomenon 2: Dots are missing in random positions.

Solutions: The ribbon may be damaged. Replace a new one.

● **Printed characters are not what you expected**

Phenomenon 1: The fonts or characters you sent with your software did not print.

Solutions: Check whether the driver is correctly configured for your printer. For instructions, see chapter 1.10.

Phenomenon 2: The font selected on the control panel can not be printed.

Solutions: Your software may be overriding your control panel setting. Use the font setting in your software program.

● **The print position is not what you expected**

Phenomenon 1: The printing home position is not correct or the bottom part of one page is printed at the top of the next page.

Solutions:

1. See chapter 2.2.4 to adjust the printing home position.
2. Check the page length set by your software and adjust it in the software or in the printer to match

the paper length.

Phenomenon 2: Regular gaps occur in the printout.

Solutions: Skip-over-perforation may be on. Set skip-over-perforation to off in the printer setting mode. See "Changing the printer settings".

4.3 Paper Handling

- **Cut sheets do not be fed properly**

Phenomenon 1: Paper does not feed.

Solutions:

1. Tractor paper may be left in the printer. Remove the tractor paper. Set the paper select lever to the cut sheet position. Insert a new sheet.
2. May be the sensor can not check there is paper if there is no tractor paper in the printer and the paper select lever is in the proper position. Try to move the paper a little left to make sure to touch the paper feed sensor.

Phenomenon 2: Paper feeding is crooked or the paper jammed.

Solutions: Turn off the printer and pull out the jammed paper. Reinsert a piece of cut sheet straight into the paper guide, and adjust the paper guide to match with paper width. Make sure that the window is closed, and power on again.

Phenomenon 3: Paper does not eject completely.

Solutions:

1. Use the **EJECT/LOAD** key to eject the paper.
2. Make sure the window is closed.
3. The paper may be too long. Check whether the paper used meets the specifications specified in the Appendix, and the Using paper must be within the specified range. See the paper specifications in the Appendix.

- **Tractor paper does not feed properly**

Phenomenon 1: The tractor does not feed the paper.

Solutions:

1. Check that the paper select lever is pulled forward to the tractor paper position. If not, move the lever to the correct position.
2. If this problem still can not be solved. The cause may be that the paper has come off the tractor. Reinstall the paper to the tractor.

Phenomenon 2: Paper feeding is crooked or the paper jammed.

Solutions:

1. Make sure the paper guide is in the upright position.
2. Make sure the position of your paper supply can not prevent it from feeding vertically.
3. Make sure your paper supply is positioned within 1 meter (3 feet) off the printer.
4. Make sure the window is closed.
5. Make sure the edge guide positions are correct. Position the edge guides at the triangular guide marks.
6. Check that the holes on the both sides of the paper are aligned with each other. Also, make sure the sprocket units are locked and their covers are closed.
7. Check whether the paper specifications meet the standard request according to the Appendix A.

Phenomenon 3: The paper does not eject completely.

Solutions:

1. May be the page length is too long. When using the drive tractor, tear off the last paper printed out, then press the **EJECT/LOAD** key to feed the paper backward.
2. Please make sure the paper length is within prescribed range. (Refer to the paper specifications in Appendix A)

Phenomenon 4: When you switch between cut sheets and tractor paper, the beeper sounds several times and the online indicator is off.

Solutions: There is paper left in the paper in channel while you change the paper select lever position. Return the paper select lever to the previous position and eject the paper. Then change the paper select lever position again.

4.4 Alignment Adjust Mode

Enter the alignment adjust mode to improve the print quality when the printer is used for a long time.

Note: When the gap adjust lever is in the position of 2 or above, the printer is in copy mode automatically. Users can set the gap adjust lever according to specific paper type (cut sheet or tractor paper), then adjust the alignment following the steps below:

1. Turn on the printer, make sure the printer is paper in and then turn off the printer.
2. Entering method of alignment adjust mode:
 - (1) In the online mode, press and hold on the **LF/FF** key and **TEAR** key until the **Power** and **ONLINE** indicators blink simultaneously, the printer enters LQ and DP alignment adjust mode (DP alignment adjust and LQ alignment adjust mode are adjusted respectively), then the printer would print out the LQ alignment state.
 - (2) In the online mode, press and hold on the **EJECT/LOAD** key and **TEAR** key until the **Power** and **ONLINE** indicators blink simultaneously, the printer enters graphic alignment adjust mode, and then the printer would print out the high speed graphic alignment states.
3. After entering the alignment adjust mode, press the following keys to adjust the degree of make columns:

EJECT/LOAD	Each press this key, the even line would move left with one step (30 steps is maximum)
LF/FF	Each press this key, the even line would move right with one step (30 steps is maximum)
TEAR	Switch to the next DPI adjust state
ONLINE	Store current setting to the printer (Power and ONLINE indicators blink simultaneously several times)
4. Restart the printer and exit the alignment adjust mode.

Note: Alignment adjust mode would affect the printing quality, think over before adjust it and strict to the instructions while adjusting.

Chapter 5 Printer Maintenance and Technical Service

5.1 Printer Cleaning

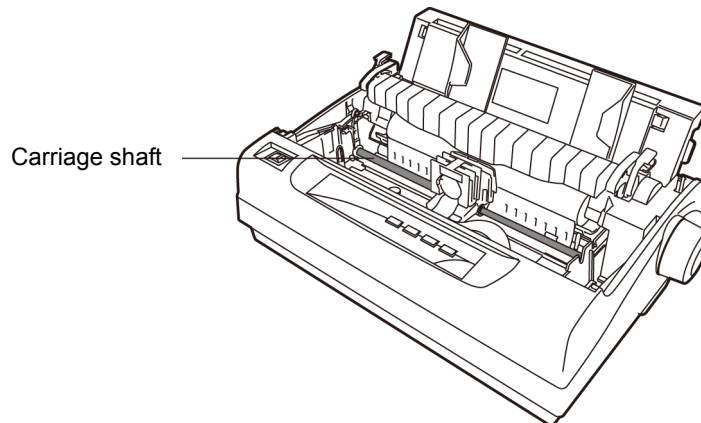

Figure 5-1 Printer cleaning

Periodical cleaning and cleaning tool

Periodical cleaning: Every 6 months or 300 working hours

Cleaning tool: Dry cloth (Use soft cloth while cleaning metal parts)

Cleaning carriage shaft

There is a layer of oil covered on the carriage shaft which guarantees the carriage runs smoothly. But the oil is easy to absorb dust, please clean the dust with soft cloth first, and then add proper lube, move print head back and forth to make lube scattered.

Cleaning the form feed path

Wipe off wastepaper, clean dirt and dust.

Note: 1. Turn off printer and pull out the power cord before cleaning.

2. Being used under dust circumstance, the carriage shaft may stack much dust and affect the print quality.
3. If you have just finished using the printer, let the print head cool for a few minutes before you touch it.
4. Please use a soft cloth for cleaning, do not use combustible solvent.

Appendix A Specifications

A.1 General

Item	Description				
Printing method	9 Pin Dot Matrix Impact Printer				
Printing width	80 columns (10 CPI)/ 203.2 mm				
Printing speed	ASCII		Normal speed (NLQ)	High speed (DRAFT)	Super high speed (SUPER-DRAFT)
		10 CPI	56 CPS	225 CPS	300 CPS
		12 CPI	67 CPS	270 CPS	337 CPS
Print head	Diameter of wire: 0.3 mm				
Resolution	240 x 144 dpi (Max.)				
Character set	ASCII: 17 international character sets (U.S.A, FRANCE, GERMANY, U.K., DENMARK1, SWEDEN, ITALY, SPAIN 1, JAPAN, NORWAY, DENMARK2, SPAIN 2, LATIN AM, KOREA, LEGAL, HOLLAND, TURKEY)				
Code page	U.S.A, MULTI, PORTUGAL, CANADA, NORWAY, ICELAND, BRASCII, ABICOMP, ROMAN 8, ISO LTN 1, PC858, ISO LTN9, ARAB NLS, WIN 1256, TURKEY, WIN LAT1, CYRILLIC, RUSSIAN, THAI, VIETNAM				
Fonts	ASCII: ROMAN, SANS SER Note: In high speed mode or super high mode, printer would automatically change the ASCII font to Draft when printing ASCII characters.				
Character pitch	ASCII: 10 CPI, 12 CPI, 15 CPI, proportional				
Line spacing	1/6 inch, programmable in 1/432 inch increments				
Paper feed Speed	Normal mode: 3 inches per second (Continuous feed) 63ms formfeed one line (1/6 inch)				
	Copy mode: 3 inches per second (Continuous feed) 63ms formfeed one line (1/6 inch)				
Emulation	EPSON ESC/PK2				
Interface	Parallel interface: Centronics (IEEE1284 NIBBLE Mode) USB interface: USB 2.0 Full-Speed Serial interface: RS-232C Note: According to specific interface standards				
Input Buffer	132 KB				
Ribbon	Model: JMR108				
	Life: 3 million characters (draft mode)				
Noise	<53 dB (A) (GB/T 18313 / ISO7779 standard)				
Control panel	The control panel consists of four keys and four indicator lights.				
Paper feed type	Cut sheet	Feed paper by friction			
	Tractor paper	Feed paper by drive tractor			
Paper thickness adjustment	Set through gap adjust lever				

Paper specification	Cut sheet (Feed by paper guide)	Width: 148 ~ 257 mm
		Thickness: 0.065 ~ 0.14 mm
		Weight: 52 ~ 90 g/m ²
	Tractor paper (Feed from rear to rear)	Width: 101.6 ~ 254 mm
Total Thickness: 0.065 ~ 0.39 mm		
Weight (Single paper): 52 ~ 82 g/m ²		
Multiple paper (Every page): 40 ~ 58 g/m ²		
Max. paper thickness	0.39 mm	
Copy	Original + 3 copies	
Compression	Support graph and character compression printing.	
Especial functions	Pin Break Compensation, Pin Rotation Replacement, Automatic Emulation Match, Online Parameter Setting	
Physical dimensions	366 (Width) × 275 (Depth) × 156 (Height) mm	
Weight	Approx. 4.3 Kg	
Environmental conditions	Operating environment	Temperature: 5 ~ 35°C
		Humidity: 25 ~ 80 %RH (No condensation)
	Storage environment	Temperature: -40 ~ 55°C
		Humidity: ≤93 (40°C, No condensation)
Power requirements	Rated voltage: AC 120V 1.2A 60Hz AC 220V-240V 0.6A 50 / 60Hz Note: Please refer to the nameplate label on the printer for detailed voltage specification.	
Electrostatic discharge Threshold	Contact discharge: 4KV Air / indirect discharge: 6KV	
Power consumption	① Operation: 47 W; ② Maximum: 130 W; ③ Sleep mode: 2.8 W. Note: Only when the produce doesn't connect power supply, could consume zero energy.	
Safety standard	UL, c-UL, UL NOM Mark, UL AR Mark, FCC class B	

A.2 Interface Specifications

Your printer can be equipped with a parallel interface, a USB interface or a serial interface. The printer switches automatically to the appropriate interface when it receives data.

A.2.1 Parallel Interface

The parallel interface has the following characteristics.

- Data format:** 8-bit
- Synchronization:** /STROBE pulse
- Handshaking:** BUSY and /ACKNLG signals
- Signal level:** TTL compatible

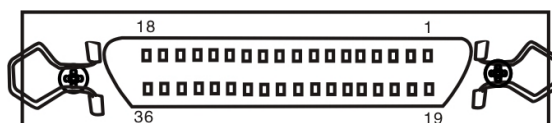

Figure A-1 Parallel interface connector pin numbers

A.2.2 USB Interface

The following table provides the standardized contact terminating assignments by number and color for Series "A" and Series "B" connectors of Full-speed USB 2.0.

Contact Number	Signal Name	Color
1	VBUS	Red
2	D-	White
3	D+	Green
4	GND	Black

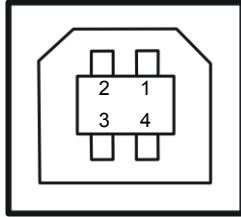

Figure A-2 USB-B type connector

A.2.3 Serial Interface

The serial interface has the following characteristics.

Baudrate (bps): 1200 bps, 2400 bps, 4800 bps, 9600 bps, 19200 bps (selectable)

Data length: 7 or 8-bit (selectable)

Start bit: 1 bit

Parity bit: Odd, even, or none (selectable)

Stop bit: 1 bit

Handshaking: DTR protocol, XON/XOFF protocol (selectable)

Serial pin assignments

The following table lists the serial connector pin assignments and describes their respective interface signals.

Pin No.	Signal	Direction	Description
1	Protective Ground (FG)	—	Printer's chassis ground
2	Transmitted Data (TXD/SD)	Out	Printer has transmitted serial data
3	Received Data (RXD/RD)	In	Printer has received serial data
7	Signal Ground (SG)	—	Return path for data control signals
20	Data Terminal Ready (DTR)	Out	Positive when the printer is ready to receive data, and negative when the printer is not ready

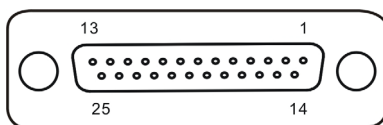

Figure A-3 Serial interface connector pin numbers

Appendix B Paper Specification

B.1 Paper Specification and Printable Area

B.1.1 The Notice Relates to Paper

Using the following paper will cause unstable paper feeding, paper jam or paper crease, even leads to break pin. So it is forbidden using.

- Too thin or too thick, or the thickness of which are uneven. (The paper which doesn't accord with paper specification)
- Too small or too large. (The paper which doesn't accord with paper specification)
- Paper being cut out or has hole.
- Paper with metal such as pins, clips and staples.
- Paper with paste outside, or which is uneven or flake off.
- Rough paper
- Tractor paper has crease besides the cross-perforation.
- Paper corner breaks or creased.

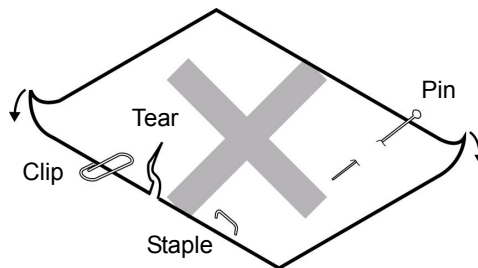
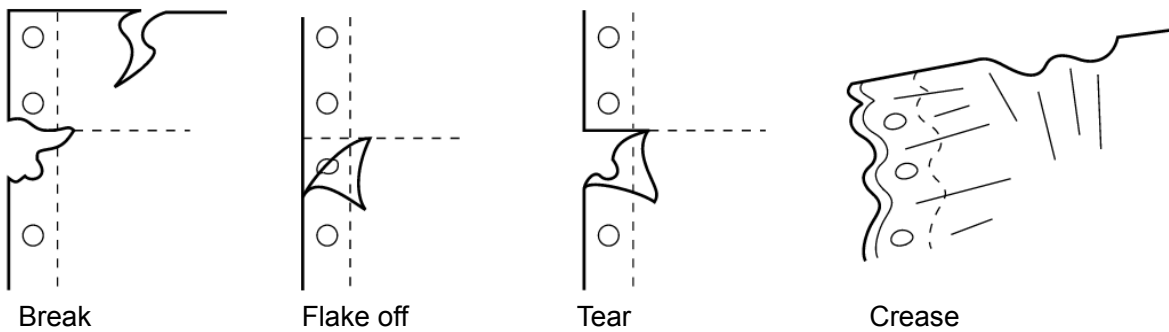

Note: 1. The storage of the paper should be in the temperature between 10°C to 30°C and the relative humidity between 30% to 70%.

2. When there is difference between operating environment and storage environment, please put the sealed paper in the operating environment a period of time. Use it after the paper is adapted to the operating environment.

B.1.2 Useable Paper Types and Guarantee Area

Useable papers are shown in the following table:

Paper type	Guarantee grade	Other conditions
Cut sheet	●	
Continuous paper	●	
Card	×	
Envelope	×	
Delivery order form	▲	
Postcard	×	
Deposit book	×	
Label	×	
Recycled paper	●	

Caution: “Guarantee” here means the specifications which accord with print specification, noise specification and paper feed performance, etc.

The meanings of symbol in Guarantee grade column are shown as follows:

- : Guarantee
- ▲ : Can use in some conditions, not guarantee.
- × : Forbid using.

- Caution:**
- To guarantee the print quality, please ensure the contents are all within printable area.
 - If the print contents are out of the printable area, it may cause the print head to break pins.

B.1.3 Cut sheet

The detailed specification of cut sheet is shown in the following table.

Paper	Single-ply paper	White paper, Copy paper
	Multi-ply paper	NCR paper
Copy capability (Max.)	4 copies (Original + 3 copies), paper weight bases on 40g/ m ² standard.	
Weight	Single-ply paper: 52 ~ 90 g/m ²	
	Multi-ply paper (each sheet): 40 ~ 64 g/m ² [Note: See details in the multi-ply paper (NCR paper) requirement table]	
Total thickness	Multi-ply paper	≤0.26 mm (Note 1)

Note: 1. Refer to the requirement of the multi-ply paper (NCR paper), the mount paper can be thicker than other plies, but we can't guarantee the printing effect as it is influenced by paper difference.

◆ Cut Sheet Dimension and Printable area

- Single-ply paper

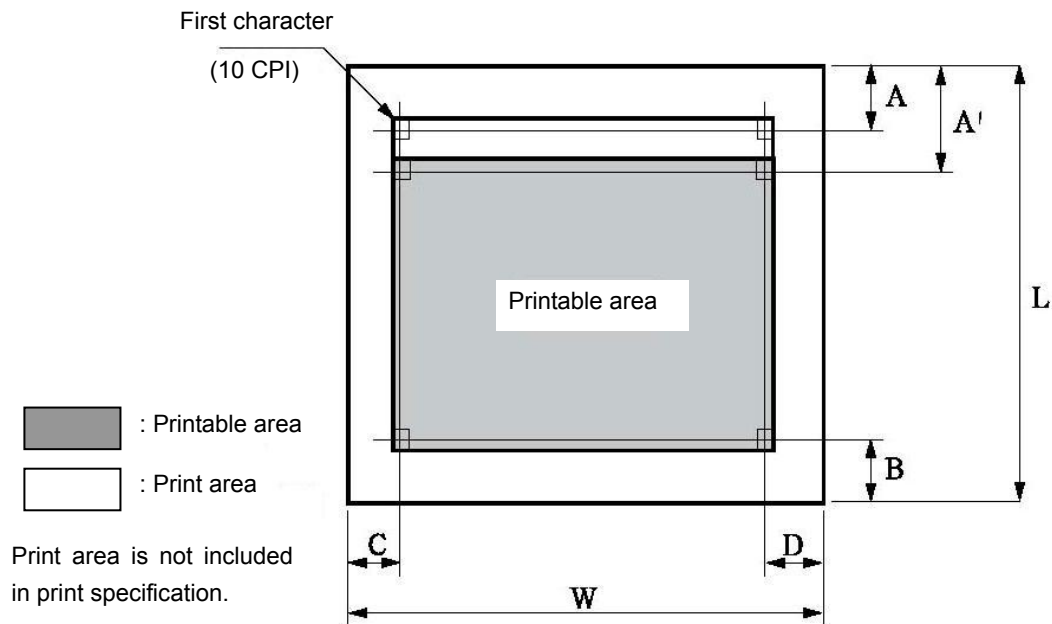

Mark	Name	Specification value
W	Paper width	148 ~ 257 mm
L	Paper length	≥90 mm (Note 1)
A	Home position	≥2 mm
A'	Top printing unguaranteed area	≥8 mm
B	Bottom printing unguaranteed area	≥9 mm
C	Left printing unguaranteed area	≥3 mm
D	Right printing unguaranteed area	≥3 mm

Caution: 1. Paper less than 45 kg (52 kg/m²) is worse in rigidity, so it is not in the guarantee list.

2. Please use the paper with no crease or bend.

3. Do not print beyond the printable area, or it may cause print head break pins and affect print head life.

B.1.4 Tractor Paper

Tractor paper is the continuous paper which has gear holes and the traverse perforations lines. Refer to the following table for the requirement of tractor paper.

Paper	Single-ply paper	White paper
	Multi-ply paper	NCR paper
Width	101.6 ~ 254 mm	
Length	≥ 145 mm	
Copy capability (Max.)	4 copies (Original + 3 copies), paper weight bases on 40g/ m ² standard.	
Weight	Single-ply paper: 52 ~ 82 g/m ²	
	Multi-ply paper (each sheet): 40 ~ 64 g/m ² [Note: See details in the multi-ply paper (NCR paper) requirement table]	
Total thickness	Single-ply paper	≤0.39 mm (Note 1)
	Multi-ply paper	≤0.26 mm (Note 2)

Note: 1. This thickness is added by multi single-ply papers, and it is only achieved when just printing on the upper paper. (No need to copy)

Note: 2. Refer to the requirement of the multi-ply paper (NCR paper), the mount paper can be thicker than other plies, but we can't guarantee the printing effect as it is influenced by paper difference.

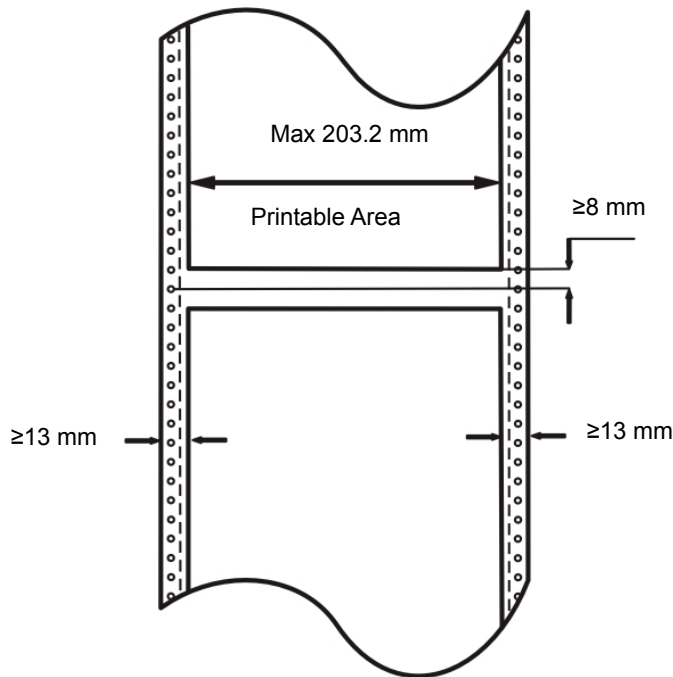

◆ The position and size of gear hole

The gear hole of tractor paper should accord with the specification.

The positions and sizes of gear hole are shown below. The central line here refers to the line between any two gear hole centers which in the distance of 254mm in either side of the paper.

Figure of tractor paper specification and gear hole

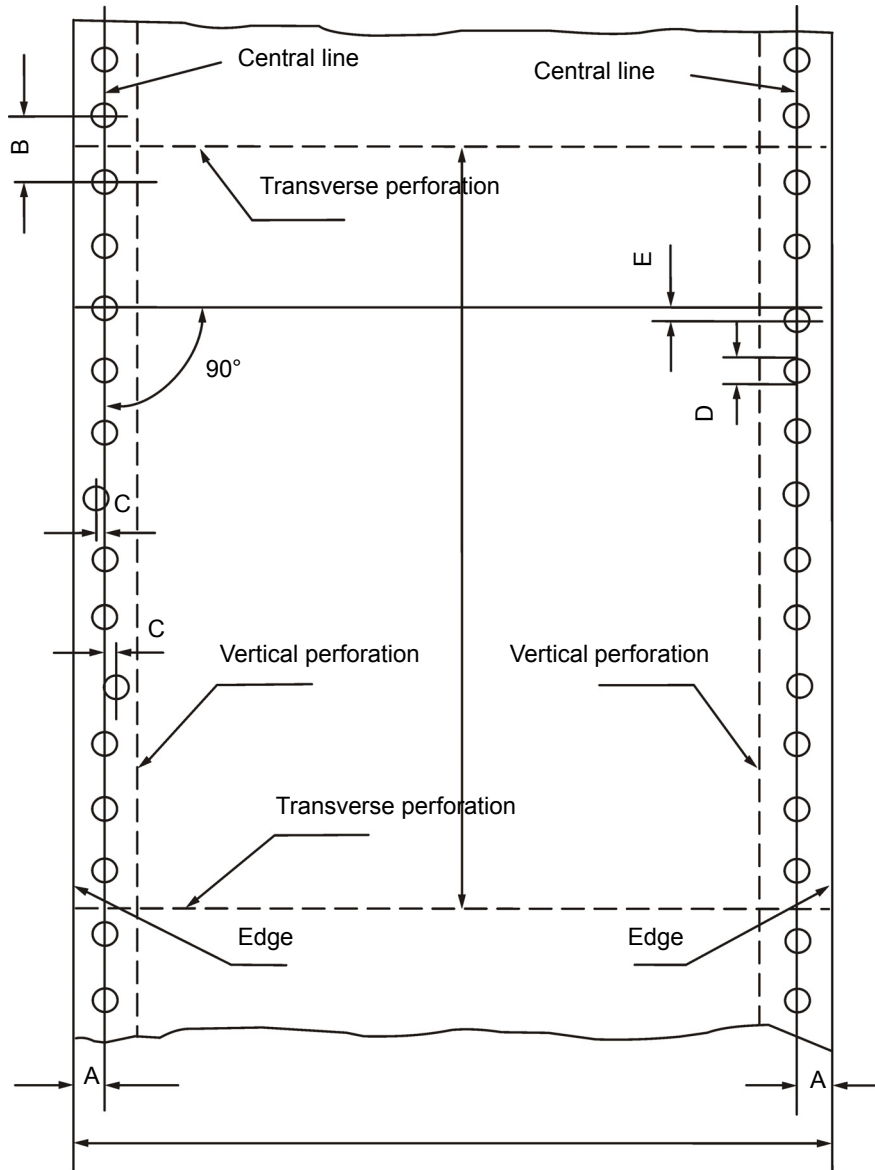

Item	Mark	Size (mm)	Function
Position of Central line	A	6.0 ± 0.7	The distance from central line to the nearer edge. The standard distance is 6.35mm.
Diameter of gear hole	D	4.0 ± 0.1	It is the hole with gear edge, its minimal diameter is the D value and its maximal diameter is 4.5mm. When using the multi-ply paper with gear holes, it is allowed that the diameter of the gear hole is bigger than 4.1mm.
Distance between gear hole centers	B	12.70 ± 0.05	Distance between nearby gear hole centers in the same side.
Accumulative error of distance between gear hole centers	-	Below ± 0.3	The accumulative error along the central line of any two gear holes which are 254mm apart.

Warp of gear hole center	C	Below 0.1	The maximal warp of the gear hole center in the same side.
Central warp of right and left gear holes.	E	Below 0.15	The warp value of the beeline which perpendiculars to central line through any gear hole in the left and the center of corresponding gear hole in the right.
Lean of right and left central line	-	Below 0.15	The distance to other end when the parallel moved right and left central lines superposes with one end.

◆ Requirement of transverse perforation

The transverse perforation should not across the gear hole, but it should at the center of two adjacent gear holes, as well as, the wrap should not over 0.1mm.

The edge of the transverse perforation should be straight, it should not be broken, and the crease should superpose with the transverse perforation.

◆ Requirement of Multi-ply paper

This printer support the multi-ply paper which the fixed method is point pulp, line pulp or paper binding. It is strictly prohibited to use the multi-ply paper which is fixed through metal staple.

○ Point Pulp

- Point pulp should be in both ends, it is not allow pointing pulp only in one end.
- The point pulp position should be the same. and the size is $\Phi 3 \sim \Phi 5\text{mm}$.
- The position of point pulp should be pressed down tightly to avoid warping.
- There should not be any obvious crease on the point pulp position.
- Each page of the point pulp paper is interleaving. (Interleaving between each ply)
- The position of point pulp is shown as below.

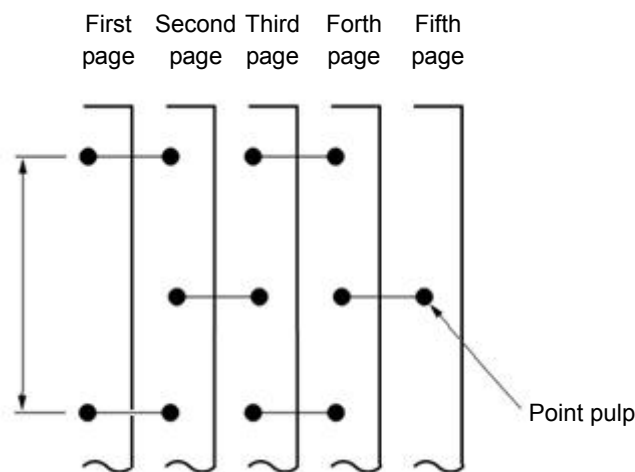

○ Line Pulp

- The line pulp position should be the same. and the width is 1 ~ 2mm.
- The position of line pulp should be pressed down tightly to avoid warping.
- Line pulp fixing should not use the paper which is obviously crease.
- Please don't bare the pulp at the edge of paper.

Note: If the place with pulp is hard, as the result, the paper will not be fed precisely.

First page Second page Third page Forth page Fifth page

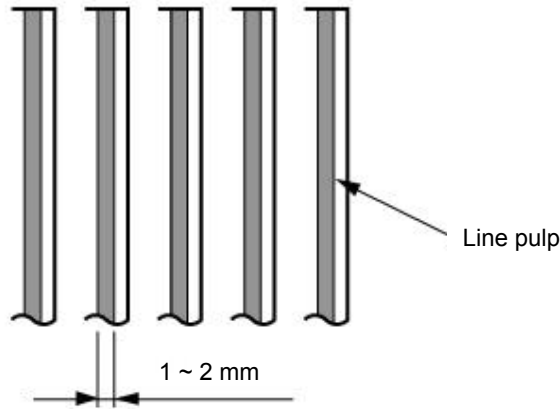

○ Paper Binding

- Paper binding should be in both ends, it is not allow paper binding only in one end.
- Paper binding should be in the paper side and the surface should be even.
- Please operate double-ply paper binding along the paper feeding direction.
- Make sure paper binding part is fixed tightly and does not wrap.
- Please press it down tightly after paper binding to avoid warping.

Note: Use the paper which is not accordance with the paper binding requirement and the specification shown below, paper feeding precision may be affected and the printing performance can not be guaranteed.

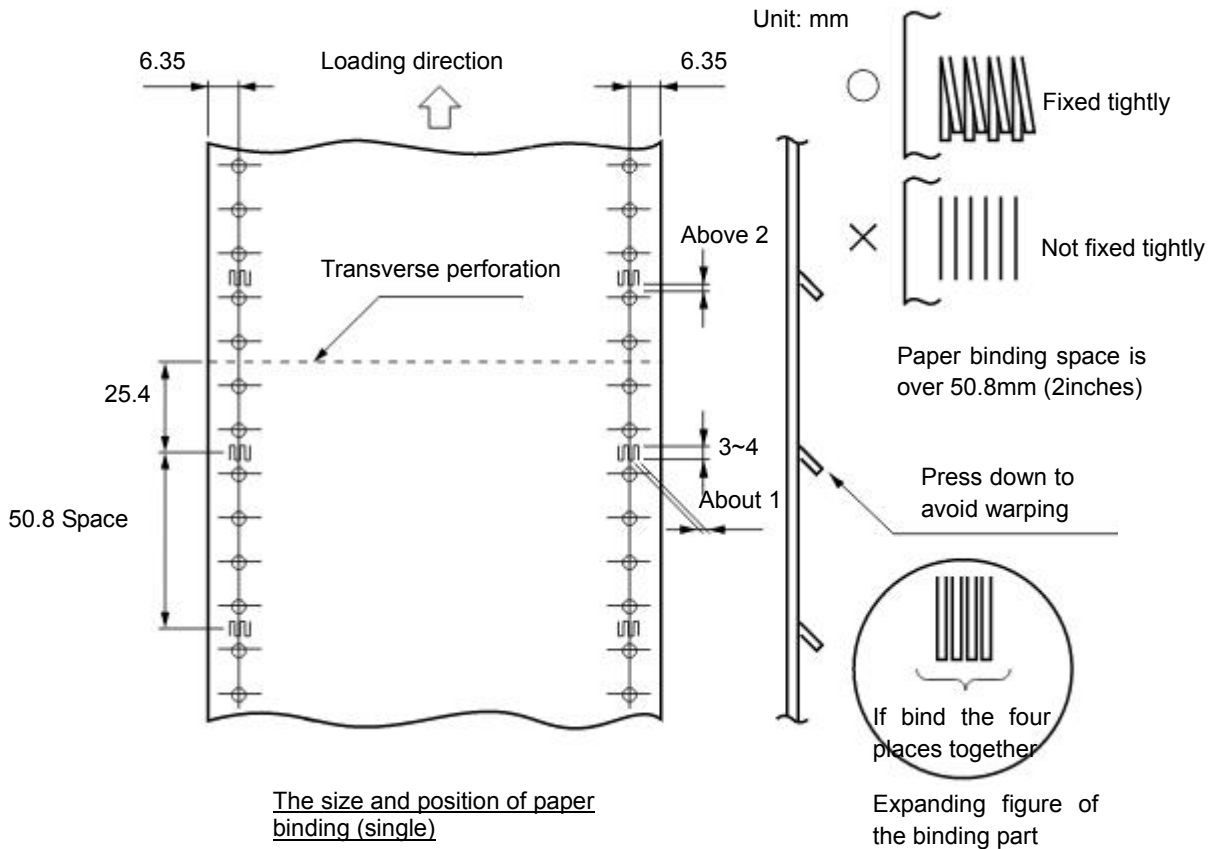

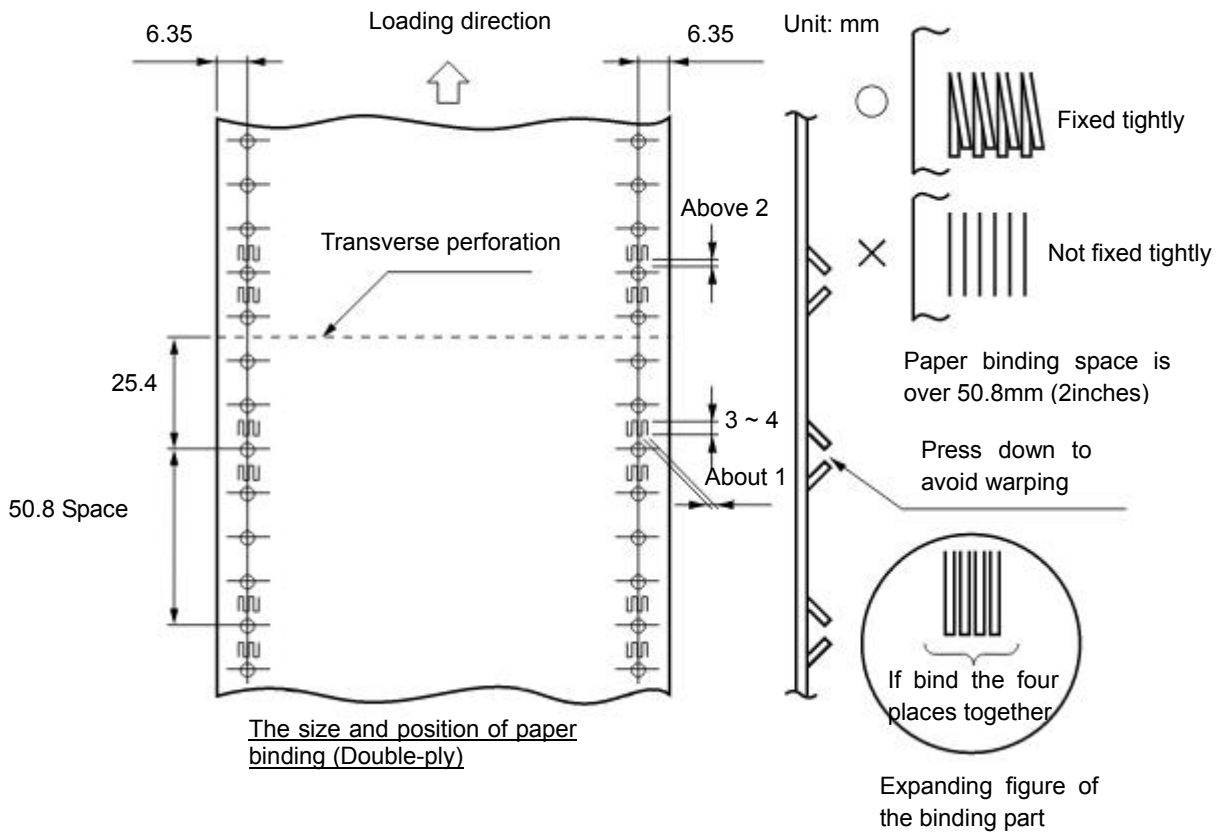

◆ Requirement of Multi-ply paper (NCR paper)

It is recommended to use the multi-ply paper which is first class or above. Low class NCR paper would affect the copy effect and printer life.

Specification of NCR multi-ply paper is shown below:

Pages	2-ply	3-ply	4-ply
Page 1	40~64 g/m ²	40~50 g/m ²	40 g/m ²
Page 2	40~80 g/m ²	40~50 g/m ²	40 g/m ²
Page 3	----	40~80 g/m ²	40 g/m ²
Page 4	----	----	40~80 g/m ²

◆ The protuberance of transverse perforation

When the fanfold transverse perforation sticks up, it may cause print quality decrease, unstable paper feed or paper jam etc. Especially when the multi-ply paper with many pages, it will deeply affect the stable of paper feed. Please ensure the protuberance height less than 1 mm.

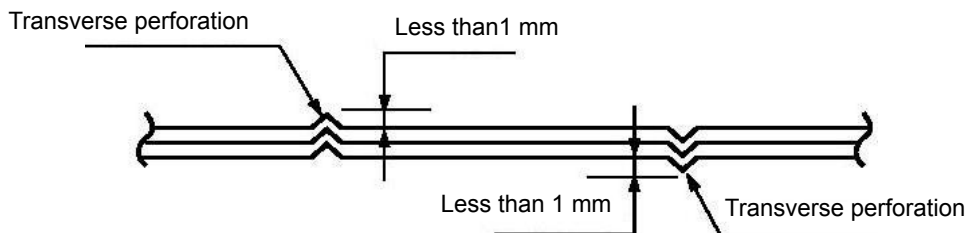

◆ Warp between toothed holes of each ply

Please use the paper which toothed holes warp between each ply (causes by the warp of multi-ply papers superposition) is less than 0.4 mm.

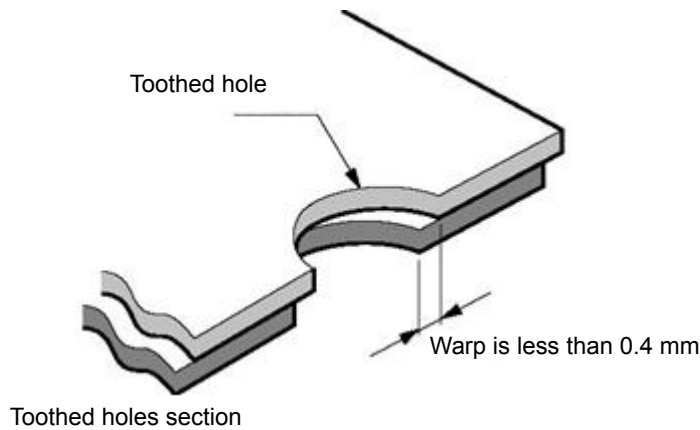

◆ Binding hole, Clipped corner

It is not support the paper which is with binding holes and clipped corners.

Caution: Do not use the paper with clipped corner or binding hole which is not include in the guarantee list. It can not guarantee device's capability after using it.

◆ Rurple, crease

The paper should not have creases or rumples, especially for new paper. The first and last pages are easy to have creases or rumples, so please do not use them.

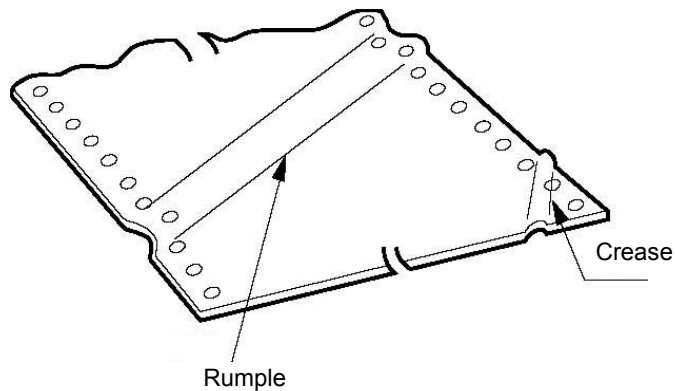

◆ The crease, crimp, fold and upturning of the paper top and bottom

Please do not use the paper which is crease, puckered, crimp and upturning in the top and bottom. Or it may cause cheap printing quality or paper jam. Especially for the new paper, if it is crease from the first few pages, please do not use it.

◆ Paper folding part

Please fold the paper base on the transverse perforation. It will affect paper feeding while the folding part sticks up as the following figure shown, please not use it.

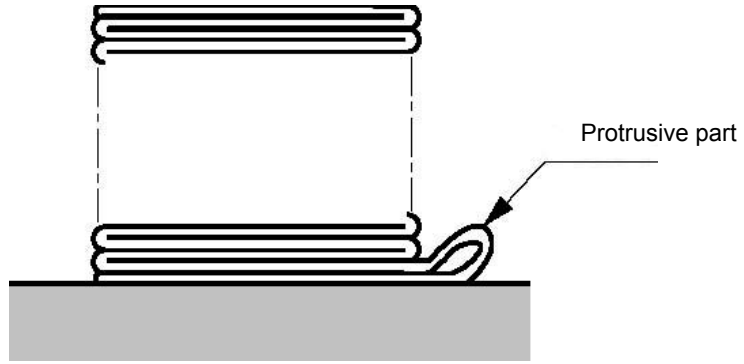

Appendix C Command Summary

This printer supports EPSON ESC/PK2 control commands shown as the follow table:

Classify	No	Command	Description
Printer Control Commands	1	ESC @	Initialize Printer
	2	CAN	Cancel Line
	3	DEL	Delete Character
	4	ESC #	Cancel MSB Control Sequence
	5	ESC >	Set MSB to 1
	6	ESC =	Reset MSB to 0
	7	BEL	Beeper
	8	BS	Backspace
	9	ESC U	Select Print Direction
	10	ESC <	Select character Unidirectional Mode (on one line)
	11	ESC s n	Select/Cancel Quiet Print Mode
	12	CR	Carriage Return
	13	LF	Line Feed
	14	FF	Form Feed
	15	ESC \$	Set Absolute Horizontal print position
	16	ESC \	Set Relative Horizontal print position
	17	ESC (U	Define Unit
	18	ESC (V	Set Absolute Vertical Print Position
	19	ESC (v	Set Relative Vertical Print Position
	20	ESC J	n/180" Line Feed
	21	ESC j	n/180" Reverse Line Feed
	22	HT	Horizontal Tab
	23	VT	Vertical Tab
Image and Color Handling	24	ESC ? m n	Reassign Graphics Mode
	25	ESC *	Set Graphics Mode
	26	ESC (G	Select Graphics Mode
	27	ESC .	Print Raster Graphics
	28	ESC K	8 dot Single-Density Graphics Mode
	29	ESC L	8 dot Double-Density Graphics Mode
	30	ESC Y	8 dot High-speed, Double-Density Graphics Mode
	31	ESC Z	8 dot Quadruple-Density Graphics Mode
Chinese Character Print Command	32	FS &	Set Chinese character mode
	33	FS ·	Cancel Chinese character mode
	34	FS SO	Select Double Width Mode (Chinese)
	35	FS DC4	Cancel Double Width Mode

Chinese Character Print Command	36	FS W	Select/Cancel quadruple-size mode for Chinese character
	37	FS J	Select lengthways printing
	38	FS K	Select transverse printing
	39	FS D	Two character lengthways half-size mode paratactically printing
	40	FS -	Select/Cancel Underline Mode for Chinese character
	41	FS S	Select full-size mode pitch for Chinese character
	42	FS T	Select half-size mode pitch for Chinese character
	43	FS U	Select half-size mode pitch adjustment for character
	44	FS V	Cancel half-size mode pitch adjustment for character
	45	FS x	Select /Cancel high speed printing
	46	FS 2	Chinese character of user-defined
	47	FS SI	Select half-size mode for Chinese character
	48	FS DC2	Cancel half-size mode for Chinese character
	49	FS r	Select demisemi-size mode for Chinese character
	50	FS !	Select Chinese character print mode
	51	FS v	Select/Cancel form connect line
	52	FS k	Select Chinese font
	53	FS Y	Select Chinese character dot-matrix and width
	54	FS c	Set Chinese character HMI (Horizontal motion space)
	55	FS b	Set Chinese character datum line
56	ESC I	Select Chinese CC-DOS print mode	
ASCII Character	57	ESC k	Select Font Style
	58	ESC X	Select ASCII character width and height
	59	ESC P	Select 10CPI Mode
	60	ESC M	Select 12CPI Mode
	61	ESC g	Select 15CPI Mode
	62	ESC p	Select/Cancel Proportional Mode
	63	ESC x	Select Print Quality
	64	ESC 4	Select Italic Mode
	65	ESC 5	Cancel Italic Mode
	66	ESC E	Select Emphasized Mode
	67	ESC F	Cancel Emphasized Mode
	68	ESC ! n	Select Print Mode
	69	ESC q n	Select Character Style
	70	ESC t n	Select Character Table
	71	ESC (t	Assign Character Table
	72	ESC R	Select International Character Set
	73	ESC &	Define Downloaded Characters

ASCII Character	74	ESC :	Copy ROM Characters Set into RAM
	75	ESC % n	Select/Deselect User-Defined Set
	76	ESC 6	Enable Character Set 2
	77	ESC 7	Cancel command ESC 6
Font Enhancement	78	SI	Select Compressed Mode
	79	DC2	Cancel Compressed Mode
	80	SO	Select Double Width Mode
	81	DC4	Cancel Double Width Mode
	82	ESC W n	Select/Cancel Double Width Mode
	83	ESC w n	Select/Cancel Double height Mode
	84	ESC G	Select Double Strike Mode
	85	ESC H	Cancel Double Strike Mode
	86	ESC - n	Select/Cancel Underline Mode
	87	ESC (-	Define and Apply a Style of Scoring
	88	ESC (^	Print Data as Characters
	89	ESC S n	Select Superscript/Subscript Mode
90	ESC T	Cancel Superscript/Subscript Mode	
Format Control	91	ESC C	Set Form Length in Lines
	92	ESC C NUL	Set Form Length in Inches
	93	ESC (C	Set Form Length in Defined Unit
	94	ESC (c	Define Form Format
	95	ESC N n	Select Skip-Over-Perforation
	96	ESC O	Cancel Skip-Over-Perforation
	97	ESC I	Set Left Margin
	98	ESC Q	Set right Margin
	99	ESC D	Set Horizontal Tab Positions
	100	ESC B	Set Vertical Tab Positions
	101	ESC /	Select a VFU Channel
	102	ESC b	Select VFU Positions
	103	ESC 0	Select 1/8-inch Line Spacing
	104	ESC 2	Select 1/6-inch Line Spacing
	105	ESC 3	Select n/180-inch Line Spacing
	106	ESC A	Select n/60-inch Line Spacing
	107	ESC +	Select n/360-inch Line Spacing
	108	ESC SP	Set Character Space
	109	ESC a n	Select Justification Mode

CITIZEN SYSTEMS AMERICA CORPORATION

363 Van Ness Way, Suite 404

Torrance, CA 90501. USA

Tel: (310) 781-1460

Fax:(310) 781-9152

<http://www.citizen-systems.com>

PXZ00098-10

PMC-1309