

## TEST REPORT



Applicant	CT Asia
Address:	Unit 01, 15/F, Seaview Centre, 139-141 Hoi bun road, Kwun Tong, Kowloon, Hongkong

Manufacturer or Supplier	Shenzhen Tinno Mobile Technology Corp.	
Location	4/F., H-3 Building, OCT Eastern Industrial park. No.1 Xiangshan East Road, Nanshan District, Shenzhen, P.R. China	
Product	Mobile Phone	
Brand Name	BLU	
Model	Tank	
Additional Model & Model Difference	N/A	
Date of tests	Sep. 24 ~ Oct. 10, 2012	

the tests have been carried out according to the requirements of the following standards:

FCC Part 15, Subpart C (Section 15.247)

**CONCLUSION: The submitted sample was found to COMPLY with the test requirement**

Prepared by Glyn He Specialist / EMC Department	Approved by Sam Tung Manager / EMC Department
	
	Date: Oct. 10, 2012

This report is for your exclusive use. Any copying or replication of this report to or for any other person or entity, or use of our name or trademark, is permitted only with our prior written permission. This report sets forth our findings solely with respect to the test samples identified herein. The results set forth in this report are not indicative or representative of the quality or characteristics of the lot from which a test sample was taken or any similar or identical product unless specifically and expressly noted. Our report includes all of the tests requested by you and the results thereof based upon the information that you provided to us. You have 60 days from date of issuance of this report to notify us of any material error or omission caused by our negligence, provided, however, that such notice shall be in writing and shall specifically address the issue you wish to raise. A failure to raise such issue within the prescribed time shall constitute your unqualified acceptance of the completeness of this report, the tests conducted and the correctness of the report contents. Unless specific mention, the uncertainty of measurement has been explicitly taken into account to declare the compliance or non-compliance to the specification



## TABLE OF CONTENTS

<b>RELEASE CONTROL RECORD</b> .....	<b>5</b>
<b>1 SUMMARY OF TEST RESULTS</b> .....	<b>6</b>
<b>2 MEASUREMENT UNCERTAINTY</b> .....	<b>6</b>
<b>3 GENERAL INFORMATION</b> .....	<b>7</b>
3.1 GENERAL DESCRIPTION OF EUT.....	7
3.2 DESCRIPTION OF TEST MODES.....	9
3.2.1. CONFIGURATION OF SYSTEM UNDER TEST .....	10
3.2.2. TEST MODE APPLICABILITY AND TESTED CHANNEL DETAIL.....	10
3.3 GENERAL DESCRIPTION OF APPLIED STANDARDS.....	12
3.4 DESCRIPTION OF SUPPORT UNITS.....	13
<b>4 TEST TYPES AND RESULTS</b> .....	<b>14</b>
4.1. CONDUCTED EMISSION MEASUREMENT.....	14
4.1.1 LIMITS OF CONDUCTED EMISSION MEASUREMENT .....	14
4.1.2 TEST INSTRUMENTS.....	14
4.1.3 TEST PROCEDURES .....	15
4.1.4 DEVIATION FROM TEST STANDARD .....	15
4.1.5 TEST SETUP.....	16
4.1.6 EUT OPERATING CONDITIONS .....	16
4.1.7 TEST RESULTS.....	17
4.2. RADIATED EMISSION AND BANDEDGE MEASUREMENT .....	19
4.2.1 LIMITS OF RADIATED EMISSION AND BANDEDGE MEASUREMENT .....	19
4.2.2 TEST INSTRUMENTS.....	20
4.2.3 TEST PROCEDURES.....	21
4.2.4 DEVIATION FROM TEST STANDARD.....	21
4.2.5 TEST SETUP .....	22
4.2.6 EUT OPERATING CONDITIONS .....	22
4.2.7 TEST RESULTS.....	23
4.3. NUMBER OF HOPPING FREQUENCY USED.....	31
4.3.1. LIMIT OF HOPPING FREQUENCY USED .....	31
4.3.2. TEST SETUP.....	31
4.3.3. TEST INSTRUMENTS.....	31
4.3.4. TEST PROCEDURES .....	31
4.3.5. DEVIATION FROM TEST STANDARD .....	32
4.3.6. TEST RESULTS.....	32



**BUREAU  
VERITAS**

**Test Report No.: RF120924N006**

4.4. DWELL TIME ON EACH CHANNEL .....	35
4.4.1 LIMIT OF DWELL TIME USED .....	35
4.4.2 TEST SETUP .....	35
4.4.3 TEST INSTRUMENTS .....	35
4.4.4 TEST PROCEDURES .....	35
4.4.5 DEVIATION FROM TEST STANDARD .....	36
4.4.6 TEST RESULTS .....	36
4.5. CHANNEL BANDWIDTH .....	44
4.5.1 LIMITS OF CHANNEL BANDWIDTH .....	44
4.5.2 TEST SETUP .....	44
4.5.3 TEST INSTRUMENTS .....	44
4.5.4 TEST PROCEDURE .....	44
4.5.5 DEVIATION FROM TEST STANDARD .....	45
4.5.6 EUT OPERATING CONDITION .....	45
4.5.7 TEST RESULTS .....	45
4.6. HOPPING CHANNEL SEPARATION .....	49
4.6.1. LIMIT OF HOPPING CHANNEL SEPARATION .....	49
4.6.2. TEST SETUP .....	49
4.6.3. TEST INSTRUMENTS .....	49
4.6.4. TEST PROCEDURES .....	49
4.6.5. DEVIATION FROM TEST STANDARD .....	49
4.6.6. TEST RESULTS .....	50
4.7. MAXIMUM OUTPUT POWER .....	52
4.7.1 LIMITS OF MAXIMUM OUTPUT POWER MEASUREMENT .....	<b>52</b>
4.7.2 TEST SETUP .....	<b>52</b>
4.7.3 TEST INSTRUMENTS .....	<b>52</b>
4.7.4 TEST PROCEDURES .....	<b>52</b>
4.7.5 DEVIATION FROM TEST STANDARD .....	<b>53</b>
4.7.6 EUT OPERATING CONDITION .....	<b>53</b>
4.7.7 TEST RESULTS .....	<b>53</b>
4.8. BAND EDGES MEASUREMENT .....	55
4.8.1 LIMITS OF BAND EDGES MEASUREMENT .....	55
4.8.2 TEST INSTRUMENTS .....	55
4.8.3 TEST PROCEDURE .....	55
4.8.4 DEVIATION FROM TEST STANDARD .....	<b>55</b>
4.8.5 EUT OPERATING CONDITION .....	<b>55</b>
4.8.6 TEST RESULTS .....	<b>56</b>



**BUREAU  
VERITAS**

**Test Report No.: RF120924N006**

<b>5. PHOTOGRAPHS OF THE TEST CONFIGURATION .....</b>	<b>60</b>
<b>6. APPENDIX A - MODIFICATIONS RECORDERS FOR ENGINEERING CHANGES TO THE EUT BY THE LAB.....</b>	<b>61</b>



**BUREAU  
VERITAS**

Test Report No.: RF120924N006

## RELEASE CONTROL RECORD

ISSUE NO.	REASON FOR CHANGE	DATE ISSUED
Original release	N/A	Oct. 10, 2012



# 1 SUMMARY OF TEST RESULTS

The EUT has been tested according to the following specifications:

APPLIED STANDARD: FCC Part 15, Subpart C			
STANDARD SECTION	TEST TYPE AND LIMIT	RESULT	REMARK
15.207	AC Power Conducted Emission	PASS	Meet the requirement of limit. Minimum passing margin is -14.76dB at 0.43579MHz.
15.247(a)(1) (iii)	Number of Hopping Frequency Used	PASS	Meet the requirement of limit.
15.247(a)(1) (iii)	Dwell Time on Each Channel	PASS	Meet the requirement of limit.
15.247(a)(1)	1. Hopping Channel Separation 2. Spectrum Bandwidth of a Frequency Hopping Sequence Spread Spectrum System	PASS	Meet the requirement of limit.
15.247(b)	Maximum Peak Output Power	PASS	Meet the requirement of limit.
15.247(d)	Transmitter Radiated Emissions	PASS	Meet the requirement of limit. Minimum passing margin is -7.6dB at 7323MHz
15.247(d)	Band Edge Measurement	PASS	Meet the requirement of limit.
15.203	Antenna Requirement	PASS	No antenna connector is used.

**NOTE:** If The Frequency Hopping System operating in 2400-2483.5MHz band and the output power less than 125mW. The hopping channel carrier frequencies separated by a minimum of 25kHz or two-thirds of the 20dB bandwidth of hopping channel whichever is greater.

# 2 MEASUREMENT UNCERTAINTY

Where relevant, the following measurement uncertainty levels have been estimated for tests performed on the EUT as specified in CISPR 16-4-2:

MEASUREMENT	FREQUENCY	UNCERTAINTY
Conducted emissions	9kHz~30MHz	2.94dB
Radiated emissions	30MHz ~ 1000MHz	3.6419dB
	1GHz ~ 18GHz	2.2dB
	18GHz ~ 40GHz	1.94dB

This uncertainty represents an expanded uncertainty expressed at approximately the 95% confidence level using a coverage factor of k=2.



### 3 GENERAL INFORMATION

#### 3.1 GENERAL DESCRIPTION OF EUT

<b>EUT</b>	Mobile Phone
<b>MODEL NO.</b>	Tank
<b>FCC ID</b>	YHLBLUTANKII
<b>POWER SUPPLY</b>	5.0VDC (adapter or host equipment) ; 3.7VDC (battery)
<b>MODULATION TYPE</b>	FHSS
<b>OPERATING FREQUENCY</b>	2402MHz~2480MHz
<b>NUMBER OF CHANNEL</b>	79
<b>MAX. OUTPUT POWER</b>	6.84dBm
<b>ANTENNA TYPE</b>	Dipole antenna with 1.33 dBi gain
<b>I/O PORTS</b>	USB Port
<b>DATA CABLE</b>	USB Cable: Shielded, Detachable, 1.0m Earphone Cable: Unshielded, Detachable, 1.0m

**NOTE:**

- There are Bluetooth, GSM technology used for the EUT. and the functions of EUT listed as below table:

Function	Report No.
Bluetooth	RF120924N006
2G & 3G (Part 22)	RF120924N006-1
2G & 3G (Part 24)	RF120924N006-2

- The EUT was powered by the following adapters:

ADAPTER	
BRAND:	BLU
MODEL:	US-01-001
INPUT:	AC 100-240V 50/60Hz 0.15A
OUTPUT:	DC 5V 500mA
DC LINE:	N/A

- The above EUT information is declared by manufacturer and for more detailed features description, please refer to the manufacturer's specifications or User's Manual.



**BUREAU  
VERITAS**

**Test Report No.: RF120924N006**

**Bureau Veritas Shenzhen Co., Ltd.  
Dongguan Branch**

No. 34, Chenwulu Section, Guantai Rd., Houjie  
Town, Dongguan City,  
Guangdong 523942, China

Tel: +86 769 8593 5656  
Fax: +86 769 8593 1080  
Email: [customerservice.dg@cn.bureauveritas.com](mailto:customerservice.dg@cn.bureauveritas.com)





### 3.2 DESCRIPTION OF TEST MODES

79 channels are provided to this EUT:

CHANNEL	FREQ. (MHz)	CHANNEL	FREQ. (MHz)	CHANNEL	FREQ. (MHz)	CHANNEL	FREQ. (MHz)
0	2402	20	2422	40	2442	60	2462
1	2403	21	2423	41	2443	61	2463
2	2404	22	2424	42	2444	62	2464
3	2405	23	2425	43	2445	63	2465
4	2406	24	2426	44	2446	64	2466
5	2407	25	2427	45	2447	65	2467
6	2408	26	2428	46	2448	66	2468
7	2409	27	2429	47	2449	67	2469
8	2410	28	2430	48	2450	68	2470
9	2411	29	2431	49	2451	69	2471
10	2412	30	2432	50	2452	70	2472
11	2413	31	2433	51	2453	71	2473
12	2414	32	2434	52	2454	72	2474
13	2415	33	2435	53	2455	73	2475
14	2416	34	2436	54	2456	74	2476
15	2417	35	2437	55	2457	75	2477
16	2418	36	2438	56	2458	76	2478
17	2419	37	2439	57	2459	77	2479
18	2420	38	2440	58	2460	78	2480
19	2421	39	2441	59	2461		



### 3.2.1. CONFIGURATION OF SYSTEM UNDER TEST

#### TEST MODE A

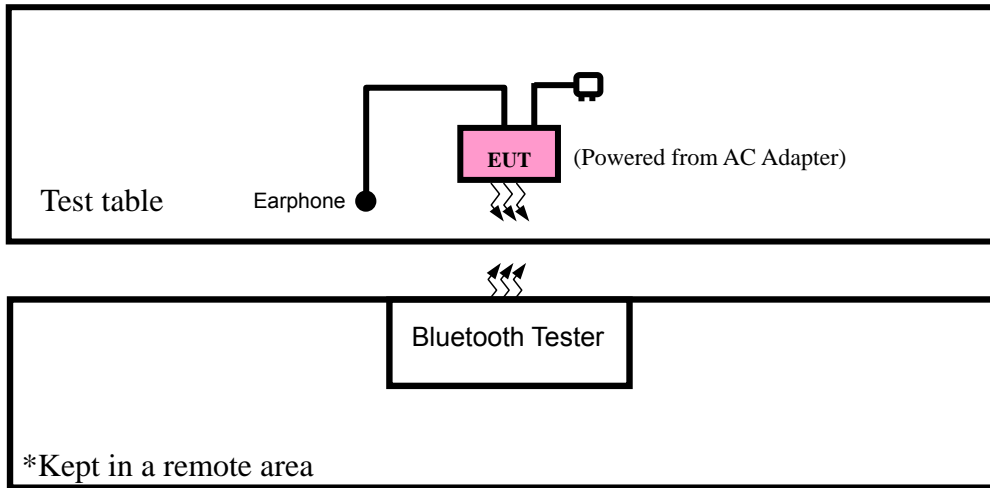

### 3.2.2. TEST MODE APPLICABILITY AND TESTED CHANNEL DETAIL

Pre-Scan has been conducted to determine the worst-case mode from all possible combinations between available modulations, data rates, XYZ axis and antenna ports

The worst case was found when positioned on Y-Z plane for radiated emission. Following channel(s) was (were) selected for the final test as listed below:

EUT CONFIGURE MODE	APPLICABLE TO				DESCRIPTION
	RE $\geq$ 1G	RE $<$ 1G	PLC	APCM	
A	√	√	√	√	EUT + Adapter + Earphone with Bluetooth link
B	-	√	NOTE	-	EUT + Battery + Earphone with Bluetooth link
C	-	√	√	-	EUT + USB Charger + Earphone with Bluetooth link

Where **RE $\geq$ 1G**: Radiated Emission above 1GHz      **RE $<$ 1G**: Radiated Emission below 1GHz  
**PLC**: Power Line Conducted Emission      **APCM**: Antenna Port Conducted Measurement  
**NOTE**: No need to concern of Conducted Emission due to the EUT is powered by battery.



**RADIATED EMISSION TEST (ABOVE 1 GHz):**

- Pre-Scan has been conducted to determine the worst-case mode from all possible combinations between available modulations, XYZ axis, antenna ports (if EUT with antenna diversity architecture) and packet type.
- Following channel(s) was (were) selected for the final test as listed below.

AVAILABLE CHANNEL	TESTED CHANNEL	MODULATION TECHNOLOGY	MODULATION TYPE	PACKET TYPE	Axis
0 to 78	0, 39, 78	FHSS	GFSK	DH5	Y-Z
0 to 78	0, 39, 78	FHSS	8DPSK	DH5	Y-Z

**RADIATED EMISSION TEST (BELOW 1 GHz):**

- Pre-Scan has been conducted to determine the worst-case mode from all possible combinations between available modulations, XYZ axis, antenna ports (if EUT with antenna diversity architecture) and packet type.
- Following channel(s) was (were) selected for the final test as listed below.

EUT CONFIGURE MODE	AVAILABLE CHANNEL	TESTED CHANNEL	MODULATION TECHNOLOGY	MODULATION TYPE	PACKET TYPE	AXIS
A	0 to 78	78	FHSS	GFSK	DH5	Y-Z

**BANDEDGE MEASUREMENT:**

- Pre-Scan has been conducted to determine the worst-case mode from all possible combinations between available modulations, antenna ports (if EUT with antenna diversity architecture), and packet types.
- Following channel(s) was (were) selected for the final test as listed below.

AVAILABLE CHANNEL	TESTED CHANNEL	MODULATION TECHNOLOGY	MODULATION TYPE	PACKET TYPE
0 to 78	0, 78	FHSS	GFSK	DH5
0 to 78	0, 78	FHSS	8DPSK	DH5



**ANTENNA PORT CONDUCTED MEASUREMENT:**

- This item includes all test value of each mode, but only includes spectrum plot of worst value of each mode.
- Pre-Scan has been conducted to determine the worst-case mode from all possible combinations between available modulations, antenna ports (if EUT with antenna diversity architecture), and packet types.
- Following channel(s) was (were) selected for the final test as listed below.

AVAILABLE CHANNEL	TESTED CHANNEL	MODULATION TECHNOLOGY	MODULATION TYPE	PACKET TYPE
0 to 78	0, 39, 78	FHSS	GFSK	DH5
0 to 78	0, 39, 78	FHSS	8DPSK	DH5

**TEST CONDITION:**

APPLICABLE TO	ENVIRONMENTAL CONDITIONS	INPUT POWER (SYSTEM)	TESTED BY
RE≥1G	25deg. C, 65%RH	120Vac, 60Hz	Venless Long
RE<1G	25deg. C, 65%RH	120Vac, 60Hz	Venless Long
APCM	25deg. C, 68%RH	120Vac, 60Hz	Venless Long

**3.3 GENERAL DESCRIPTION OF APPLIED STANDARDS**

The EUT is a RF Product. According to the specifications of the manufacturer, it must comply with the requirements of the following standards:

**FCC Part 15, Subpart C. (15.247)**

- ANSI C63.4-2003
- ANSI C63.10-2009

All test items have been performed and recorded as per the above standards.

**NOTE:** The EUT is also considered as a kind of computer peripheral, because the connection to computer is necessary for typical use. It has been verified to comply with the requirements of FCC Part 15, Subpart B, Class B . The test report has been issued separately.



### 3.4 DESCRIPTION OF SUPPORT UNITS

The EUT has been tested as an independent unit together with other necessary accessories or support units. The following support units or accessories were used to form a representative test configuration during the tests.

NO.	PRODUCT	BRAND	MODEL NO.	SERIAL NO.	FCC ID
1	Bluetooth Tester	R&S	CBT	100325	N/A

NO.	SIGNAL CABLE DESCRIPTION OF THE ABOVE SUPPORT UNITS
1.	N/A



## 4 TEST TYPES AND RESULTS

### 4.1. CONDUCTED EMISSION MEASUREMENT

#### 4.1.1 LIMITS OF CONDUCTED EMISSION MEASUREMENT

FREQUENCY OF EMISSION (MHz)	CONDUCTED LIMIT (dBµV)	
	Quasi-peak	Average
0.15 ~ 0.5	66 to 56	56 to 46
0.5 ~ 5	56	46
5 ~ 30	60	50

- NOTE:** 1. The lower limit shall apply at the transition frequencies.  
2. The limit decreases in line with the logarithm of the frequency in the range of 0.15 to 0.50MHz.  
3. All emanations from a class A/B digital device or system, including any network of conductors and apparatus connected thereto, shall not exceed the level of field strengths specified above.

#### 4.1.2 TEST INSTRUMENTS

DESCRIPTION & MANUFACTURER	MODEL NO.	SERIAL NO.	DATE OF CALIBRATION	DUE DATE OF CALIBRATION
EMI Test Receiver Rohde&Schwarz	ESU26	100005	May 15,12	May 14,13
Artificial Mains Network Rohde&Schwarz	ENV216	101173	May 15,12	May 14,13
Artificial Mains Network Rohde&Schwarz	ESH2-Z5	100071	May 15,12	May 14,13
RF Cable FUJIKURA	3D-2W	553 Cable	May 15,12	May 14,13
Test software	ADT_Cond_V7.3.7	N/A	N/A	N/A

- NOTE:** 1. The calibration interval of the above test instruments is 12 months and the calibrations are traceable to CEPREI/CHINA and NIM/CHINA  
2. The test was performed in Dongguan Shielded Room 553.



#### 4.1.3 TEST PROCEDURES

- a. The EUT was placed 0.4 meters from the conducting wall of the shielded room with EUT being connected to the power mains through a line impedance stabilization network (LISN). Other support units were connected to the power mains through another LISN. The two LISNs provide 50 ohm/ 50uH of coupling impedance for the measuring instrument.
- b. Both lines of the power mains connected to the EUT were checked for maximum conducted interference.
- c. The frequency range from 150kHz to 30MHz was searched. Emission levels under (Limit - 20dB) was not recorded.

**NOTE:** All modes of operation were investigated and the worst-case emissions are reported.

#### 4.1.4 DEVIATION FROM TEST STANDARD

No deviation.



#### 4.1.5 TEST SETUP

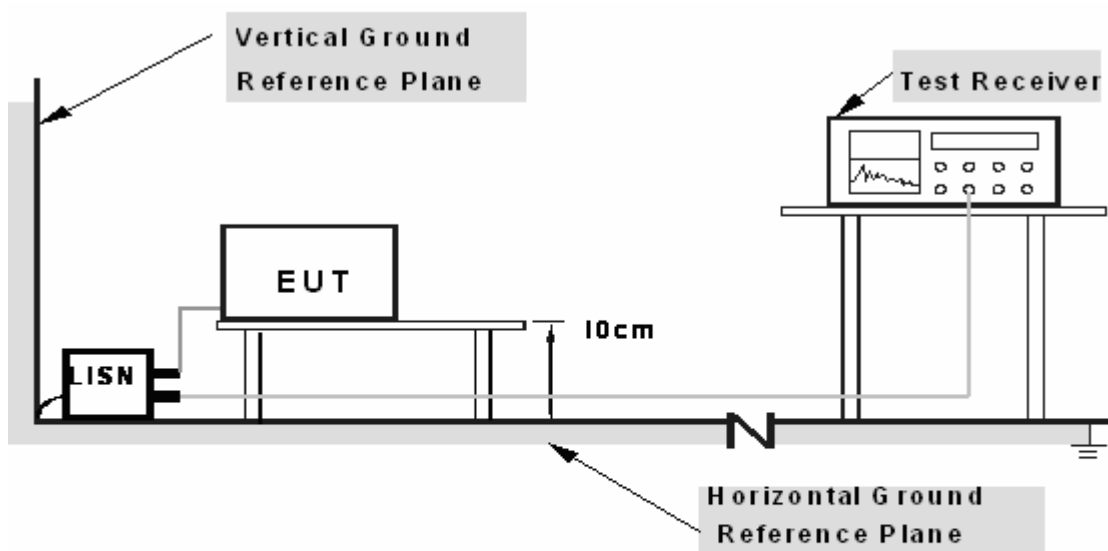

- Note: 1. Support units were connected to second LISN.**  
**2. Both of LISNs (AMN) are 80 cm from EUT and at least 80 from other units and other metal planes**

For the actual test configuration, please refer to the attached file (Test Setup Photo).

#### 4.1.6 EUT OPERATING CONDITIONS

- Turned on the power and connected of all equipment.
- EUT was operated according to the type used was description in manufacturer's specifications or the User's Manual.





### 4.1.7 TEST RESULTS

#### CONDUCTED WORST-CASE DATA:

<b>PHASE</b>	Line	<b>6dB BANDWIDTH</b>	9kHz
--------------	------	----------------------	------

No	Freq. [MHz]	Corr. Factor (dB)	Reading Value [dB (uV)]		Emission Level [dB (uV)]		Limit [dB (uV)]		Margin (dB)	
			Q.P.	AV.	Q.P.	AV.	Q.P.	AV.	Q.P.	AV.
1	0.16173	10.61	28.65	16.57	39.26	27.18	65.37	55.37	-26.11	-28.19
2	0.18122	10.54	22.67	14.36	33.21	24.9	64.43	54.43	-31.22	-29.53
3	0.25526	10.43	19.73	12.81	30.16	23.24	61.58	51.58	-31.43	-28.35
<b>4</b>	<b>0.43579</b>	<b>10.31</b>	<b>30.06</b>	<b>22.07</b>	<b>40.37</b>	<b>32.38</b>	<b>57.14</b>	<b>47.14</b>	<b>-16.77</b>	<b>-14.76</b>
5	0.78733	10.11	18.28	7.97	28.39	18.08	56	46	-27.61	-27.92
6	17.84666	10.18	20.27	11.26	30.45	21.44	60	50	-29.55	-28.56

- REMARKS:**
1. Q.P. and AV. are abbreviations of quasi-peak and average individually.
  2. "-": The Quasi-peak reading value also meets average limit and measurement with the average detector is unnecessary.
  3. The emission levels of other frequencies were very low against the limit.
  4. Margin value = Emission level - Limit value
  5. Correction factor = Insertion loss + Cable loss
  6. Emission Level = Correction Factor + Reading Value.

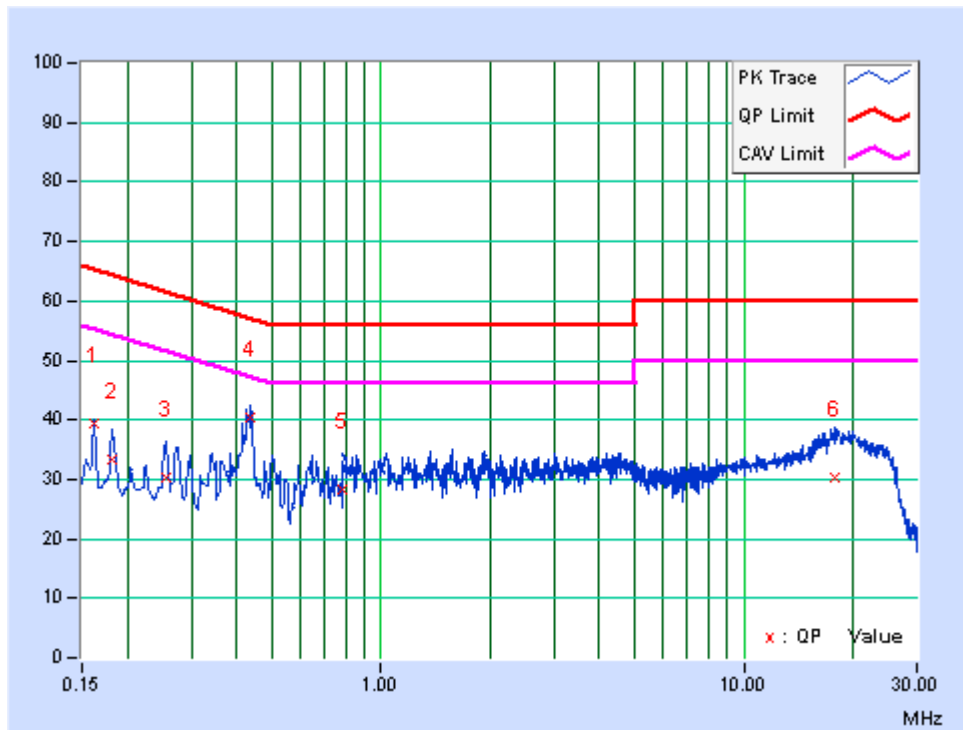



<b>PHASE</b>	Neutral	<b>6dB BANDWIDTH</b>	9kHz
--------------	---------	----------------------	------

No	Freq. [MHz]	Corr. Factor (dB)	Reading Value [dB (uV)]		Emission Level [dB (uV)]		Limit [dB (uV)]		Margin (dB)	
			Q.P.	AV.	Q.P.	AV.	Q.P.	AV.	Q.P.	AV.
1	0.16181	10.67	27.97	15.79	38.64	26.46	65.37	55.37	-26.74	-28.92
2	0.18128	10.51	22.77	13.73	33.28	24.24	64.43	54.43	-31.15	-30.19
3	0.3455	10.41	20.74	13.57	31.15	23.98	59.07	49.07	-27.92	-25.09
4	0.43122	10.44	26.67	18.33	37.11	28.77	57.23	47.23	-20.11	-18.45
5	0.50972	10.45	20.32	11.46	30.77	21.91	56	46	-25.23	-24.09
6	19.24644	10.17	18.69	12.67	28.86	22.84	60	50	-31.14	-27.16

- REMARKS:**
1. Q.P. and AV. are abbreviations of quasi-peak and average individually.
  2. "-": The Quasi-peak reading value also meets average limit and measurement with the average detector is unnecessary.
  3. The emission levels of other frequencies were very low against the limit.
  4. Margin value = Emission level - Limit value
  5. Correction factor = Insertion loss + Cable loss
  6. Emission Level = Correction Factor + Reading Value.

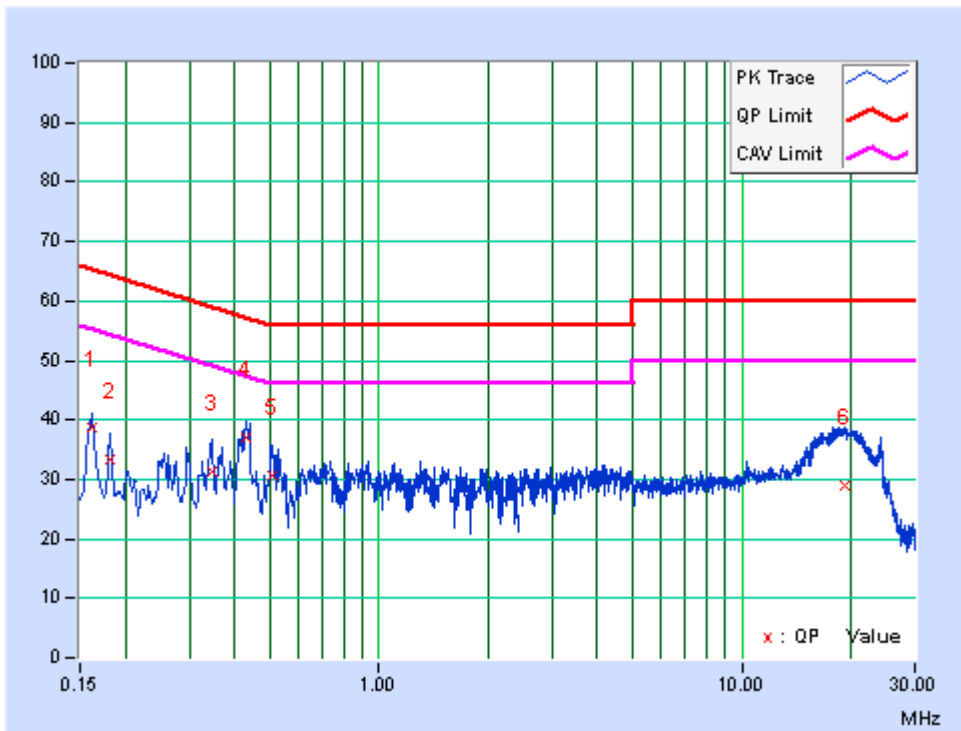



## 4.2. RADIATED EMISSION AND BANDEDGE MEASUREMENT

### 4.2.1 LIMITS OF RADIATED EMISSION AND BANDEDGE MEASUREMENT

Radiated emissions which fall in the restricted bands, as defined in Section 15.205(a), must also comply with the radiated emission limits specified in Section 15.209(a). Other emissions shall be at least 20dB below the highest level of the desired power.

FREQUENCIES (MHz)	FIELD STRENGTH (microvolts/meter)	MEASUREMENT DISTANCE (meters)
0.009 ~ 0.490	2400/F(kHz)	300
0.490 ~ 1.705	24000/F(kHz)	30
1.705 ~ 30.0	30	30
30 ~ 88	100	3
88 ~ 216	150	3
216 ~ 960	200	3
Above 960	500	3

**NOTE:**

1. The lower limit shall apply at the transition frequencies.
2. Emission level (dBuV/m) = 20 log Emission level (uV/m).
3. As shown in 15.35(b), for frequencies above 1000MHz, the field strength limits are based on average detector, however, the peak field strength of any emission shall not exceed the maximum permitted average limits, specified above by more than 20dB under any condition of modulation.



#### 4.2.2 TEST INSTRUMENTS

DESCRIPTION & MANUFACTURER	MODEL NO.	SERIAL NO.	DATE OF CALIBRATION	DUE DATE OF CALIBRATION
Spectrum Analyzer ROHDE & SCHWARZ	E4446A	MY46180622	May 02, 12	May 01, 13
Test Receiver ROHDE & SCHWARZ	ESVD	847398/004	May 15,12	May 14,13
Bilog Antenna TESEQ	CBL 6111D	25758	Nov.07,11	Nov.07,12
Horn Antenna EMCO	3117	00062558	Nov.07,11	Nov.07,12
10m Semi-anechoic Chamber ETS-LINDGREN	21.4m*12.1m*8.8m	NSEMC006	Mar 24,12	Mar 23,13
RF Cable IMRO	IMRO-400	10m Cable 1#10m	May 16,12	May 15,13
RF Cable IMRO	IMRO-400	10m Cable 2#3m	May 16,12	May 15,13
Signal Amplifier EMCI	EMC330	980095	Nov 07,11	Nov 07,12
Signal Amplifier EMCI	EMC 012645	980077	Nov 07,11	Nov 07,12
RF Cable DRAKA	M06/25-RG102	10m Cable 2#	May 16,12	May 15,13
Test software ADT	ADT_Radiated_V7. 6.15	N/A	N/A	N/A

- NOTE:**
1. The calibration interval of the above test instruments is 12 months and the calibrations are traceable to CEPREI/CHINA and NIM/CHINA.
  2. The test was performed in Dongguan Chamber 10m.
  3. The horn antenna are used only for the measurement of emission frequency above 1GHz if tested.



#### 4.2.3 TEST PROCEDURES

- a. The EUT was placed on the top of a rotating table 0.8 meters above the ground at a 3 meter semi-anechoic chamber. The table was rotated 360 degrees to determine the position of the highest radiation.
- b. The EUT was set 3 meters away from the interference-receiving antenna, which was mounted on the top of a variable-height antenna tower.
- c. The antenna is a broadband antenna, and its height is varied from one meter to four meters above the ground to determine the maximum value of the field strength. Both horizontal and vertical polarizations of the antenna are set to make the measurement.
- d. For each suspected emission, the EUT was arranged to its worst case and then the antenna was tuned to heights from 1 meter to 4 meters and the rotatable table was turned from 0 degrees to 360 degrees to find the maximum reading.
- e. The test-receiver system was set to Peak Detect Function and Specified Bandwidth with Maximum Hold Mode.
- f. If the emission level of the EUT in peak mode was lower than the limit specified, then testing could be stopped and the peak values of the EUT would be reported. Otherwise the emissions would be re-tested one by one using peak, quasi-peak or average method as specified and then reported in a data sheet.

**NOTE:**

1. The resolution bandwidth and video bandwidth of test receiver/spectrum analyzer is 120kHz for Quasi-peak detection at frequency below 1GHz.
2. The resolution bandwidth of test receiver/spectrum analyzer is 1 MHz and video bandwidth is 3MHz for Peak detection at frequency above 1GHz.
3. All modes of operation were investigated and the worst-case emissions are reported.

#### 4.2.4 DEVIATION FROM TEST STANDARD

No deviation.



#### 4.2.5 TEST SETUP

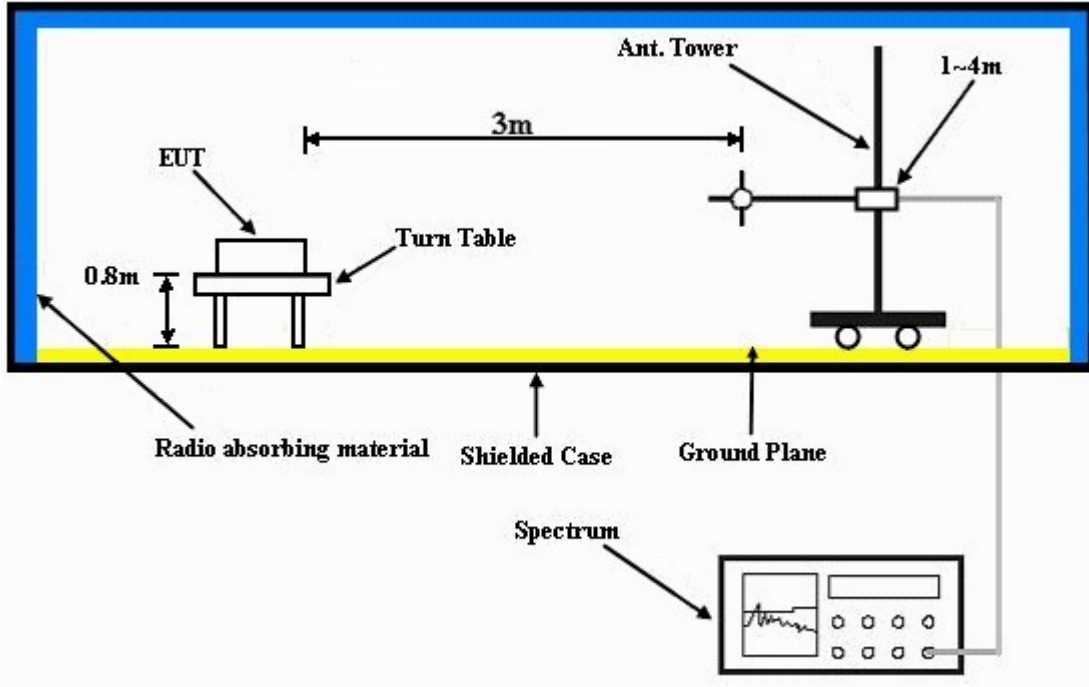

For the actual test configuration, please refer to the attached file (Test Setup Photo).

#### 4.2.6 EUT OPERATING CONDITIONS

Set the EUT under transmission condition continuously at specific channel frequency.



### 4.2.7 TEST RESULTS

#### BELOW 1GHz WORST-CASE DATA : GFSK

EUT TEST CONDITION		MEASUREMENT DETAIL	
CHANNEL	Channel 39	FREQUENCY RANGE	Below 1000MHz
INPUT POWER (SYSTEM)	120Vac, 60 Hz	DETECTOR FUNCTION	Quasi-Peak
ENVIRONMENTAL CONDITIONS	25deg. C, 68%RH	TESTED BY	Venless Long

ANTENNA POLARITY & TEST DISTANCE: HORIZONTAL AT 3M								
No.	Freq. (MHz)	Correction Factor (dB/m)	Raw Value (dBuV)	Emission Level (dBuV/m)	Limit (dBuV/m)	Margin (dB)	Antenna Height (cm)	Table Angle (Degree)
1	33.13	18.14	8.51	26.65	40	-13.35	100	207
2	88	9.45	18.01	27.46	40	-12.54	100	22
3	147.94	12.39	19.66	32.05	43.5	-11.45	100	77
4	233.64	12.2	15.22	27.42	46	-18.58	100	112
5	311.26	15.25	11.65	26.9	46	-19.1	100	131
6	416.36	18.42	9.8	28.22	46	-17.78	100	154

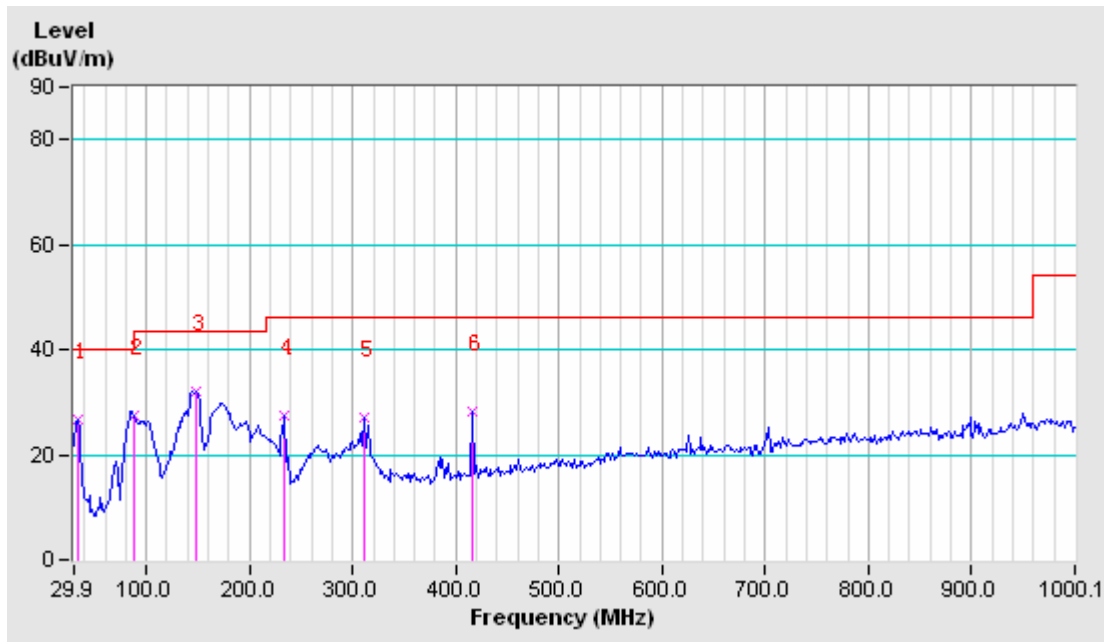



EUT TEST CONDITION		MEASUREMENT DETAIL	
CHANNEL	Channel 39	FREQUENCY RANGE	Below 1000MHz
INPUT POWER (SYSTEM)	120Vac, 60 Hz	DETECTOR FUNCTION	Quasi-Peak
ENVIRONMENTAL CONDITIONS	25deg. C, 68%RH	TESTED BY	Venless Long

ANTENNA POLARITY & TEST DISTANCE: VERTICAL AT 3M								
No.	Freq. (MHz)	Correction Factor (dB/m)	Raw Value (dBuV)	Emission Level (dBuV/m)	Limit (dBuV/m)	Margin (dB)	Antenna Height (cm)	Table Angle (Degree)
1	33.13	18.14	18.55	36.69	40	-3.31	100	295
2	84.88	9.02	22.92	31.94	40	-8.06	100	250
3	146.32	12.49	11.59	24.08	43.5	-19.42	100	274
4	165.73	11.26	10.66	21.92	43.5	-21.58	100	302
5	274.07	14.98	1.4	16.38	46	-29.62	100	360
6	384.02	17.19	3.93	21.12	46	-24.88	100	328

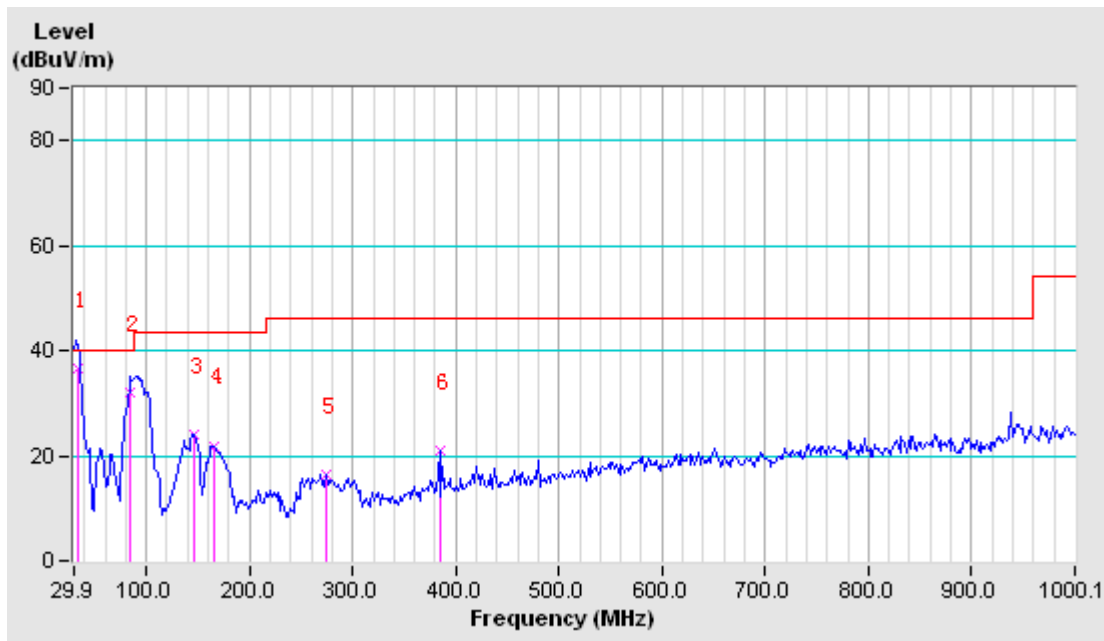

- REMARKS:**
1. Emission level (dBuV/m) = Reading (dBuV) + Factor (dB/m).
  2. Factor (dB/m) = Antenna Factor (dB/m) + Cable Factor (dB).
  3. The other emission levels were very low against the limit.
  4. Margin value = Emission level – Limit value.





ABOVE 1GHz DATA

GFSK

EUT TEST CONDITION		MEASUREMENT DETAIL	
CHANNEL	Channel 0	FREQUENCY RANGE	1 ~ 25GHz
INPUT POWER (SYSTEM)	120Vac, 60 Hz	DETECTOR FUNCTION	Peak (PK) Average (AV)
ENVIRONMENTAL CONDITIONS	25deg. C, 68%RH	TESTED BY	Venless Long

ANTENNA POLARITY & TEST DISTANCE: HORIZONTAL AT 3 M								
NO.	FREQ. (MHz)	EMISSION LEVEL (dBuV/m)	LIMIT (dBuV/m)	MARGIN (dB)	ANTENNA HEIGHT (m)	TABLE ANGLE (Degree)	RAW VALUE (dBuV)	CORRECTION FACTOR (dB/m)
1	#2390.00	51.1 PK	74.0	-22.9	1.00 H	20	14.69	36.41
2	#2390.00	21.0 AV	54.0	-33.0	1.00 H	20	-15.41	36.41
3	*2402.00	102.1 PK	114.0	-11.9	1.00 H	260	65.58	36.52
4	*2402.00	72.0 AV	94.0	-22.0	1.00 H	260	35.48	36.52
5	4804.00	65.6 PK	74.0	-8.4	1.00 H	80	16.35	49.25
6	4804.00	35.5 AV	54.0	-18.5	1.00 H	80	-13.75	49.25
ANTENNA POLARITY & TEST DISTANCE: VERTICAL AT 3 M								
NO.	FREQ. (MHz)	EMISSION LEVEL (dBuV/m)	LIMIT (dBuV/m)	MARGIN (dB)	ANTENNA HEIGHT (m)	TABLE ANGLE (Degree)	RAW VALUE (dBuV)	CORRECTION FACTOR (dB/m)
1	#2390.00	49.5 PK	74.0	-24.5	1.00 V	320	13.09	36.41
2	#2390.00	19.4 AV	54.0	-34.6	1.00 V	320	-17.01	36.41
3	*2402.00	103.7 PK	114.0	-10.3	1.00 V	12	67.18	36.52
4	*2402.00	73.6 AV	94.0	-20.4	1.00 V	12	37.08	36.52
5	#4804.00	64.7 PK	74.0	-9.3	1.00 V	260	15.45	49.25
6	#4804.00	34.6 AV	54.0	-19.4	1.00 V	260	-14.65	49.25

- REMARKS:**
1. Emission level (dBuV/m) = Raw Value (dBuV) + Correction Factor (dB/m).
  2. Correction Factor (dB/m) = Antenna Factor (dB/m) + Cable Factor (dB).
  3. The other emission levels were very low against the limit.
  4. Margin value = Emission level – Limit value.
  5. " \* ": Fundamental frequency.
  6. " # ": The radiated frequency is out of the restricted band.
  7. The DH5 packet was the worse case duty cycle for a transmit dwell time on a channel, based upon bluetooth theory the transmitter is on 0.625 \* 5 per 296.25 ms per channel. Therefore, the duty cycle correlation factor be equal to:  $20\log(3.125 / 100) = -30.1$  dB.
  8. Average value = peak reading +  $20\log(\text{duty cycle})$ .



EUT TEST CONDITION		MEASUREMENT DETAIL	
CHANNEL	Channel 39	FREQUENCY RANGE	1 ~ 25GHz
INPUT POWER (SYSTEM)	120Vac, 60 Hz	DETECTOR FUNCTION	Peak (PK) Average (AV)
ENVIRONMENTAL CONDITIONS	25deg. C, 68%RH	TESTED BY	Venless Long

ANTENNA POLARITY & TEST DISTANCE: HORIZONTAL AT 3 M								
NO.	FREQ. (MHz)	EMISSION LEVEL (dBuV/m)	LIMIT (dBuV/m)	MARGIN (dB)	ANTENNA HEIGHT (m)	TABLE ANGLE (Degree)	RAW VALUE (dBuV)	CORRECTION FACTOR (dB/m)
1	*2441.20	102.8 PK	114.0	-11.2	1.00 H	360	65.93	36.87
2	*2441.20	72.7 AV	94.0	-21.3	1.00 H	360	35.83	36.87
3	4881.80	63.1 PK	74.0	-10.9	1.00 H	120	13.87	49.23
4	4881.80	33.0 AV	54.0	-21.0	1.00 H	120	-16.23	49.23
5	7322.90	65.3 PK	74.0	-8.7	1.00 H	0	18.69	46.61
6	7322.90	35.2 AV	54.0	-18.8	1.00 H	0	-11.41	46.61
ANTENNA POLARITY & TEST DISTANCE: VERTICAL AT 3 M								
NO.	FREQ. (MHz)	EMISSION LEVEL (dBuV/m)	LIMIT (dBuV/m)	MARGIN (dB)	ANTENNA HEIGHT (m)	TABLE ANGLE (Degree)	RAW VALUE (dBuV)	CORRECTION FACTOR (dB/m)
1	*2441.00	102.3 PK	114.0	-11.7	1.00 V	0	65.43	36.87
2	*2441.00	72.2 AV	94.0	-21.8	1.00 V	0	35.33	36.87
3	4882.00	62.5 PK	74.0	-11.5	1.00 V	300	13.27	49.23
4	4882.00	32.4 AV	54.0	-21.6	1.00 V	300	-16.83	49.23
5	<b>7323.00</b>	<b>66.4 PK</b>	<b>74.0</b>	<b>-7.6</b>	<b>1.00 V</b>	<b>10</b>	<b>19.79</b>	<b>46.61</b>
6	7323.00	36.4 AV	54.0	-17.6	1.00 V	10	-10.21	46.61

- REMARKS:**
- Emission level (dBuV/m) = Raw Value (dBuV) + Correction Factor (dB/m).
  - Correction Factor (dB/m) = Antenna Factor (dB/m) + Cable Factor (dB).
  - The other emission levels were very low against the limit.
  - Margin value = Emission level – Limit value.
  - " \* ": Fundamental frequency.
  - " # ": The radiated frequency is out of the restricted band.
  - The DH5 packet was the worse case duty cycle for a transmit dwell time on a channel, based upon bluetooth theory the transmitter is on 0.625 \* 5 per 296.25 ms per channel. Therefore, the duty cycle correlation factor be equal to:  $20\log(3.125 / 100) = -30.1$  dB.
  - Average value = peak reading +  $20\log(\text{duty cycle})$ .



EUT TEST CONDITION		MEASUREMENT DETAIL	
CHANNEL	Channel 78	FREQUENCY RANGE	1 ~ 25GHz
INPUT POWER (SYSTEM)	120Vac, 60 Hz	DETECTOR FUNCTION	Peak (PK) Average (AV)
ENVIRONMENTAL CONDITIONS	25deg. C, 68%RH	TESTED BY	Venless Long

ANTENNA POLARITY & TEST DISTANCE: HORIZONTAL AT 3 M								
NO.	FREQ. (MHz)	EMISSION LEVEL (dBuV/m)	LIMIT (dBuV/m)	MARGIN (dB)	ANTENNA HEIGHT (m)	TABLE ANGLE (Degree)	RAW VALUE (dBuV)	CORRECTION FACTOR (dB/m)
1	*2480.00	101.4 PK	114	-12.6	1.00 H	200	64.19	37.21
2	*2480.00	71.3 AV	94	-22.7	1.00 H	200	34.09	37.21
3	#2483.50	53.4 PK	74.0	-20.6	1.00 H	0	16.16	37.24
4	#2483.50	23.3 AV	54.0	-30.7	1.00 H	0	-13.94	37.24
5	4960.20	65.2 PK	74.0	-8.8	1.00 H	340	15.99	49.21
6	4960.20	35.1 AV	54.0	-18.9	1.00 H	340	-14.11	49.21
ANTENNA POLARITY & TEST DISTANCE: VERTICAL AT 3 M								
NO.	FREQ. (MHz)	EMISSION LEVEL (dBuV/m)	LIMIT (dBuV/m)	MARGIN (dB)	ANTENNA HEIGHT (m)	TABLE ANGLE (Degree)	RAW VALUE (dBuV)	CORRECTION FACTOR (dB/m)
1	*2480.00	103.8 PK	114	-10.2	1.00 V	0	66.59	37.21
2	*2480.00	73.7 AV	94	-20.3	1.00 V	0	36.49	37.21
3	#2483.50	64.7 PK	74.0	-9.3	1.00 V	120	27.46	37.24
4	#2483.50	34.6 AV	54.0	-19.4	1.00 V	120	-2.64	37.24
5	4960.00	64.3 PK	74.0	-9.7	1.00 V	360	15.09	49.21
6	4960.00	34.2 AV	54.0	-19.8	1.00 V	360	-15.01	49.21

- REMARKS:**
1. Emission level (dBuV/m) = Raw Value (dBuV) + Correction Factor (dB/m).
  2. Correction Factor (dB/m) = Antenna Factor (dB/m) + Cable Factor (dB).
  3. The other emission levels were very low against the limit.
  4. Margin value = Emission level – Limit value.
  5. “ \* “: Fundamental frequency.
  6. " # ": The radiated frequency is out of the restricted band.
  7. The DH5 packet was the worse case duty cycle for a transmit dwell time on a channel, based upon bluetooth theory the transmitter is on 0.625 \* 5 per 296.25 ms per channel. Therefore, the duty cycle correlation factor be equal to:  $20\log(3.125 / 100) = -30.1$  dB.
  8. Average value = peak reading +  $20\log(\text{duty cycle})$ .



8DPSK

EUT TEST CONDITION		MEASUREMENT DETAIL	
CHANNEL	Channel 0	FREQUENCY RANGE	1 ~ 25GHz
INPUT POWER (SYSTEM)	120Vac, 60 Hz	DETECTOR FUNCTION	Peak (PK) Average (AV)
ENVIRONMENTAL CONDITIONS	25deg. C, 68%RH	TESTED BY	Venless Long

ANTENNA POLARITY & TEST DISTANCE: HORIZONTAL AT 3 M								
NO.	FREQ. (MHz)	EMISSION LEVEL (dBuV/m)	LIMIT (dBuV/m)	MARGIN (dB)	ANTENNA HEIGHT (m)	TABLE ANGLE (Degree)	RAW VALUE (dBuV)	CORRECTION FACTOR (dB/m)
1	#2390.00	56.3 PK	74.0	-17.7	1.00 H	360	19.89	36.41
2	#2390.00	26.2 AV	54.0	-27.8	1.00 H	360	-10.21	36.41
3	*2402.00	102.6 PK	114.0	-11.4	1.00 H	0	66.08	36.52
4	*2402.00	72.5 AV	94.0	-21.5	1.00 H	0	35.98	36.52
5	4804.00	63.8 PK	74.0	-10.2	1.00 H	140	14.55	49.25
6	4804.00	33.7 AV	54.0	-20.3	1.00 H	140	-15.55	49.25
ANTENNA POLARITY & TEST DISTANCE: VERTICAL AT 3 M								
NO.	FREQ. (MHz)	EMISSION LEVEL (dBuV/m)	LIMIT (dBuV/m)	MARGIN (dB)	ANTENNA HEIGHT (m)	TABLE ANGLE (Degree)	RAW VALUE (dBuV)	CORRECTION FACTOR (dB/m)
1	#2390.00	54.6 PK	74.0	-19.4	1.00 V	40	18.19	36.41
2	#2390.00	24.5 AV	54.0	-29.5	1.00 V	40	-11.91	36.41
3	*2402.00	103.8 PK	114.0	-10.2	1.00 V	0	67.28	36.52
4	*2402.00	73.7 AV	94.0	-20.3	1.00 V	0	37.18	36.52
5	4804.00	63.8 PK	74.0	-10.2	1.00 V	360	14.55	49.25
6	4804.00	33.7 AV	54.0	-20.3	1.00 V	360	-15.55	49.25

- REMARKS:**
- Emission level (dBuV/m) = Raw Value (dBuV) + Correction Factor (dB/m).
  - Correction Factor (dB/m) = Antenna Factor (dB/m) + Cable Factor (dB).
  - The other emission levels were very low against the limit.
  - Margin value = Emission level – Limit value.
  - " \* ": Fundamental frequency.
  - " # ": The radiated frequency is out of the restricted band.
  - The DH5 packet was the worse case duty cycle for a transmit dwell time on a channel, based upon bluetooth theory the transmitter is on 0.625 \* 5 per 296.25 ms per channel. Therefore, the duty cycle correlation factor be equal to:  $20\log(3.125 / 100) = -30.1$  dB.
  - Average value = peak reading +  $20\log(\text{duty cycle})$ .



EUT TEST CONDITION		MEASUREMENT DETAIL	
CHANNEL	Channel 39	FREQUENCY RANGE	1 ~ 25GHz
INPUT POWER (SYSTEM)	120Vac, 60 Hz	DETECTOR FUNCTION	Peak (PK) Average (AV)
ENVIRONMENTAL CONDITIONS	25deg. C, 68%RH	TESTED BY	Venless Long

ANTENNA POLARITY & TEST DISTANCE: HORIZONTAL AT 3 M								
NO.	FREQ. (MHz)	EMISSION LEVEL (dBuV/m)	LIMIT (dBuV/m)	MARGIN (dB)	ANTENNA HEIGHT (m)	TABLE ANGLE (Degree)	RAW VALUE (dBuV)	CORRECTION FACTOR (dB/m)
1	*2441.00	103.2 PK	114.0	-10.8	1.00 H	0	66.33	36.87
2	*2441.00	73.1 AV	94.0	-20.9	1.00 H	0	36.23	36.87
3	4882.00	63.7 PK	74.0	-10.3	1.00 H	21	14.47	49.23
4	4882.00	33.6 AV	54.0	-20.4	1.00 H	21	-15.63	49.23
5	7323.00	64.2 PK	74.0	-9.8	1.00 H	120	17.59	46.61
6	7323.00	34.1 AV	54.0	-19.9	1.00 H	120	-12.51	46.61
ANTENNA POLARITY & TEST DISTANCE: VERTICAL AT 3 M								
NO.	FREQ. (MHz)	EMISSION LEVEL (dBuV/m)	LIMIT (dBuV/m)	MARGIN (dB)	ANTENNA HEIGHT (m)	TABLE ANGLE (Degree)	RAW VALUE (dBuV)	CORRECTION FACTOR (dB/m)
1	*2441.00	102.4 PK	114.0	-11.6	1.00 V	360	65.53	36.87
2	*2441.00	72.3 AV	94.0	-21.7	1.00 V	360	35.43	36.87
3	4882.00	63.6 PK	74.0	-10.4	1.00 V	0	14.37	49.23
4	4882.00	33.5 AV	54.0	-20.5	1.00 V	0	-15.73	49.23
5	7323.00	64.5 PK	74.0	-9.5	1.00 V	132	17.89	46.61
6	7323.00	34.4 AV	54.0	-19.6	1.00 V	132	-12.21	46.61

- REMARKS:**
- Emission level (dBuV/m) = Raw Value (dBuV) + Correction Factor (dB/m).
  - Correction Factor (dB/m) = Antenna Factor (dB/m) + Cable Factor (dB).
  - The other emission levels were very low against the limit.
  - Margin value = Emission level – Limit value.
  - " \* ": Fundamental frequency.
  - " # ": The radiated frequency is out of the restricted band.
  - The DH5 packet was the worse case duty cycle for a transmit dwell time on a channel, based upon bluetooth theory the transmitter is on 0.625 \* 5 per 296.25 ms per channel. Therefore, the duty cycle correlation factor be equal to:  $20\log(3.125 / 100) = -30.1$  dB.
  - Average value = peak reading +  $20\log(\text{duty cycle})$ .



EUT TEST CONDITION		MEASUREMENT DETAIL	
CHANNEL	Channel 78	FREQUENCY RANGE	1 ~ 25GHz
INPUT POWER (SYSTEM)	120Vac, 60 Hz	DETECTOR FUNCTION	Peak (PK) Average (AV)
ENVIRONMENTAL CONDITIONS	25deg. C, 68%RH	TESTED BY	Venless Long

ANTENNA POLARITY & TEST DISTANCE: HORIZONTAL AT 3 M								
NO.	FREQ. (MHz)	EMISSION LEVEL (dBuV/m)	LIMIT (dBuV/m)	MARGIN (dB)	ANTENNA HEIGHT (m)	TABLE ANGLE (Degree)	RAW VALUE (dBuV)	CORRECTION FACTOR (dB/m)
1	*2480.00	102.2 PK	114.0	-11.8	1.00 H	268	64.99	37.21
2	*2480.00	72.1 AV	94.0	-21.9	1.00 H	268	34.89	37.21
3	#2483.50	57.2 PK	74.0	-16.8	1.00 H	270	19.96	37.24
4	#2483.50	27.1 AV	54.0	-26.9	1.00 H	270	-10.14	37.24
5	4960.00	64.7 PK	74.0	-9.3	1.00 H	280	15.49	49.21
6	4960.00	34.6 AV	54.0	-19.4	1.00 H	280	-14.61	49.21
ANTENNA POLARITY & TEST DISTANCE: VERTICAL AT 3 M								
NO.	FREQ. (MHz)	EMISSION LEVEL (dBuV/m)	LIMIT (dBuV/m)	MARGIN (dB)	ANTENNA HEIGHT (m)	TABLE ANGLE (Degree)	RAW VALUE (dBuV)	CORRECTION FACTOR (dB/m)
1	*2480.00	103.4 PK	114.0	-10.6	1.00 V	296	66.19	37.21
2	*2480.00	73.3 AV	94.0	-20.7	1.00 V	296	36.09	37.21
3	#2483.50	58.3 PK	74.0	-15.7	1.00 V	300	21.06	37.24
4	#2483.50	28.2 AV	54.0	-25.8	1.00 V	300	-9.04	37.24
5	<b>4960.00</b>	<b>64.8 PK</b>	<b>74.0</b>	<b>-9.2</b>	<b>1.00 V</b>	<b>30</b>	<b>15.59</b>	<b>49.21</b>
6	4960.00	34.7 AV	54.0	-19.3	1.00 V	30	-14.51	49.21

- REMARKS:**
- Emission level (dBuV/m) = Raw Value (dBuV) + Correction Factor (dB/m).
  - Correction Factor (dB/m) = Antenna Factor (dB/m) + Cable Factor (dB).
  - The other emission levels were very low against the limit.
  - Margin value = Emission level – Limit value.
  - " \* ": Fundamental frequency.
  - " # ": The radiated frequency is out of the restricted band.
  - The DH5 packet was the worse case duty cycle for a transmit dwell time on a channel, based upon bluetooth theory the transmitter is on 0.625 \* 5 per 296.25 ms per channel. Therefore, the duty cycle correlation factor be equal to:  $20\log(3.125 / 100) = -30.1$  dB.
  - Average value = peak reading +  $20\log(\text{duty cycle})$ .



### 4.3. NUMBER OF HOPPING FREQUENCY USED

#### 4.3.1. LIMIT OF HOPPING FREQUENCY USED

At least 15 channels frequencies, and should be equally spaced.

#### 4.3.2. TEST SETUP

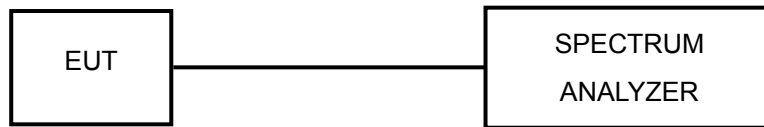

#### 4.3.3. TEST INSTRUMENTS

Refer to section 4.1.2 to get information of above instrument.

#### 4.3.4. TEST PROCEDURES

- a. Check the calibration of the measuring instrument (SA) using either an internal calibrator or a known signal from an external generator.
- b. Turn on the EUT and connect its antenna terminal to measurement via a low loss cable. Then set it to any one measured frequency within its operating range and make sure the instrument is operated in its linear range.
- c. Set the SA on MaxHold Mode, and then keep the EUT in hopping mode. Record all the signals from each channel until each one has been recorded.
- d. Set the SA on View mode and then plot the result on SA screen.
- e. Repeat above procedures until all frequencies measured were complete.



**BUREAU  
VERITAS**

**Test Report No.: RF120924N006**

#### 4.3.5. DEVIATION FROM TEST STANDARD

No deviation.

#### 4.3.6. TEST RESULTS

There are 79 hopping frequencies in the hopping mode. Please refer to next two pages for the test result. On the plots, it shows that the hopping frequencies are equally spaced.





BUREAU VERITAS

Test Report No.: RF120924N006

GFSK

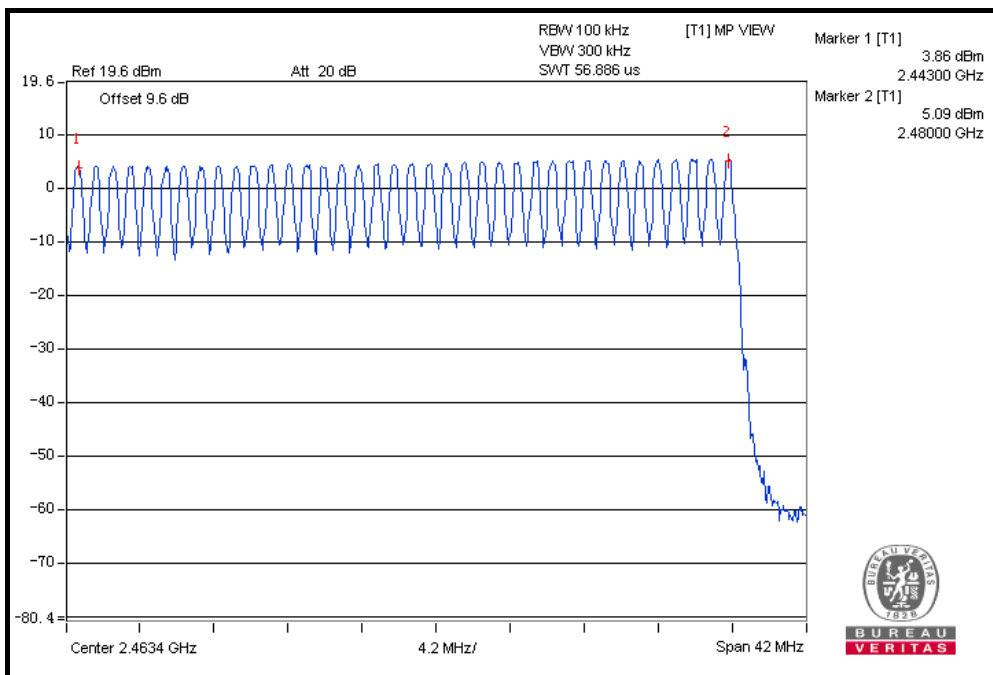
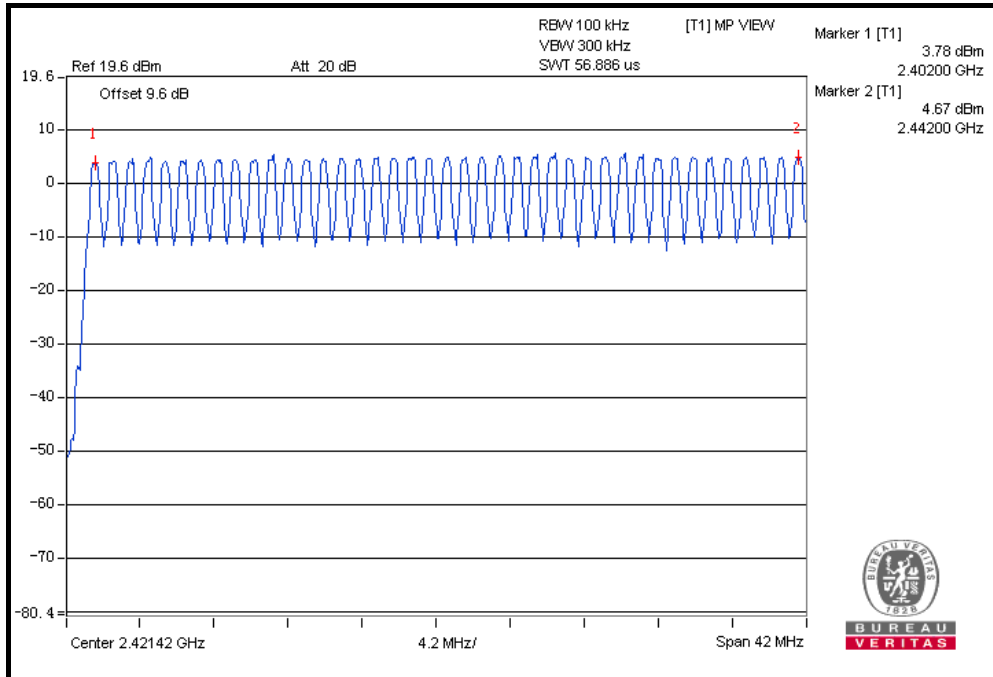



BUREAU VERITAS

Test Report No.: RF120924N006

8DPSK

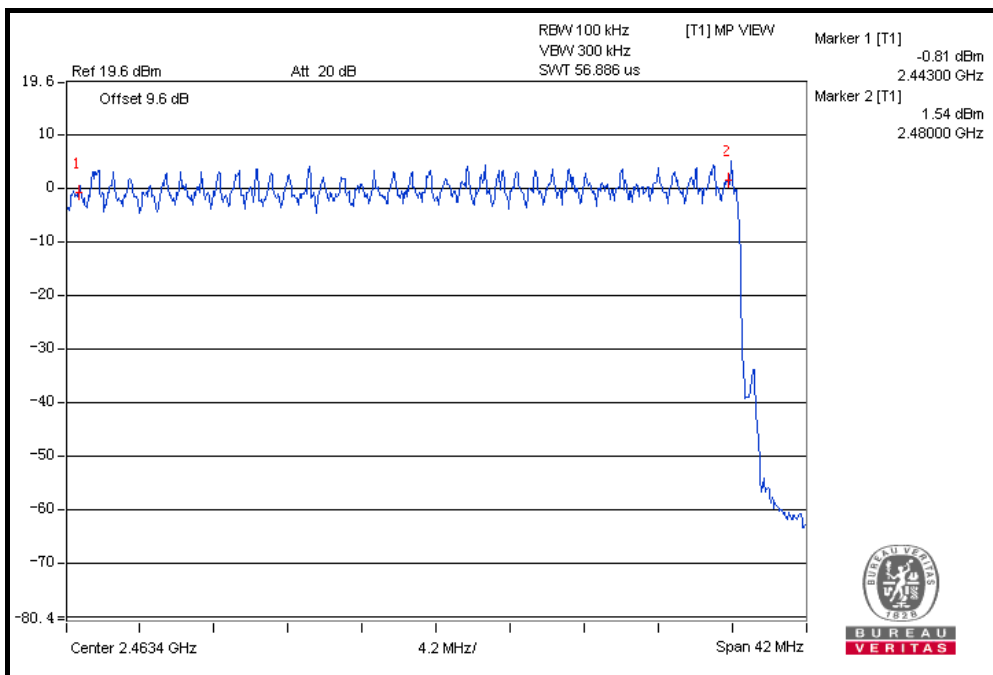
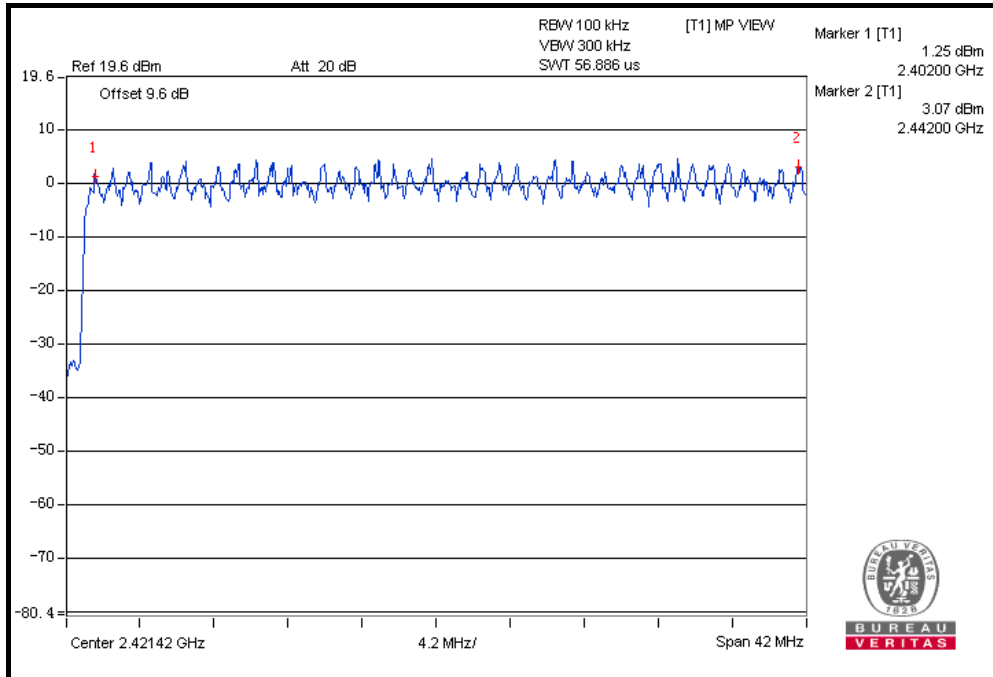



#### 4.4. DWELL TIME ON EACH CHANNEL

##### 4.4.1 LIMIT OF DWELL TIME USED

The average time of occupancy on any channel shall not be greater than 0.4 seconds within a period of 0.4 seconds multiplied by the number of hopping channels employed.

##### 4.4.2 TEST SETUP

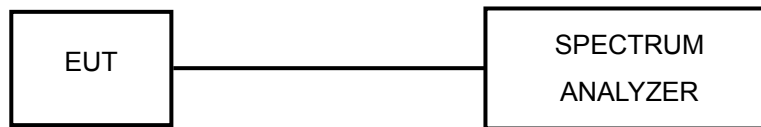

##### 4.4.3 TEST INSTRUMENTS

Refer to section 4.1.2 to get information of above instrument.

##### 4.4.4 TEST PROCEDURES

- a. Check the calibration of the measuring instrument (SA) using either an internal calibrator or a known signal from an external generator.
- b. Turn on the EUT and connect its antenna terminal to measurement via a low loss cable. Then set it to any one measured frequency within its operating range and make sure the instrument is operated in its linear range.
- c. Adjust the center frequency of SA on any frequency be measured and set SA to zero span mode. And then, set RBW and VBW of spectrum analyzer to proper value.
- d. Measure the time duration of one transmission on the measured frequency. And then plot the result with time difference of this time duration.
- e. Repeat above procedures until all different time-slot modes have been completed.



#### 4.4.5 DEVIATION FROM TEST STANDARD

No deviation.

#### 4.4.6 TEST RESULTS

##### GFSK

Mode	Number of transmission in a 31.6 (79Hopping*0.4)	Length of transmission time (msec)	Result (msec)	Limit (msec)
DH1	49 (times / 5 sec) * 6.32 = 309.68 times	0.448	138.74	400
DH3	25 (times / 5 sec) * 6.32 = 158.00 times	1.681	265.60	400
DH5	18 (times / 5 sec) * 6.32 = 113.76 times	2.95	335.60	400

**NOTE:** Test plots of the transmitting time slot are shown on next 3 pages.



BUREAU VERITAS

Test Report No.: RF120924N006

DH1

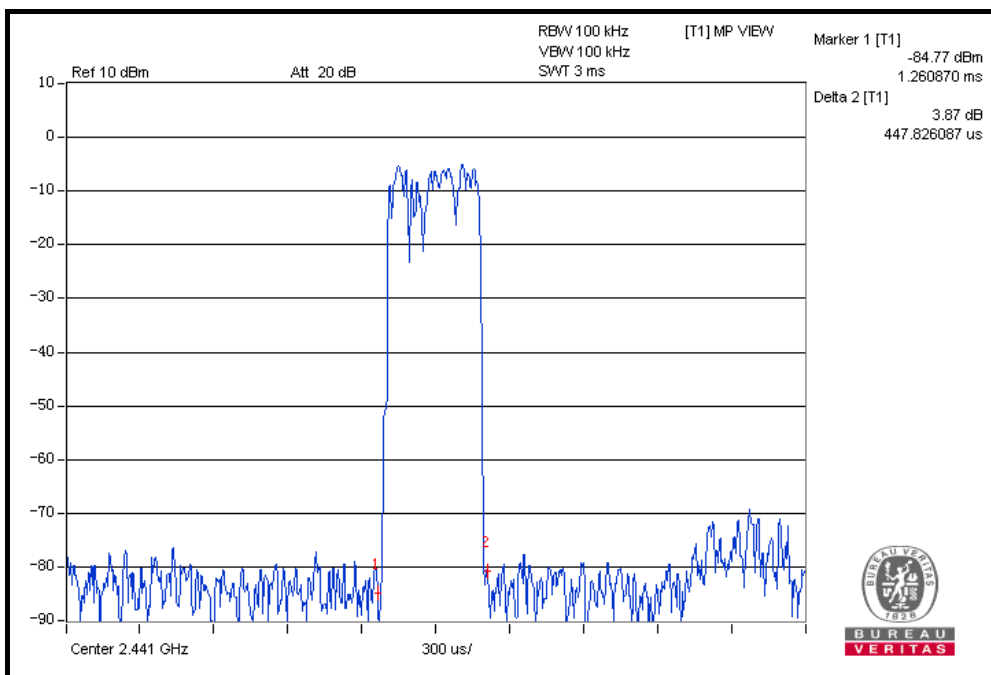
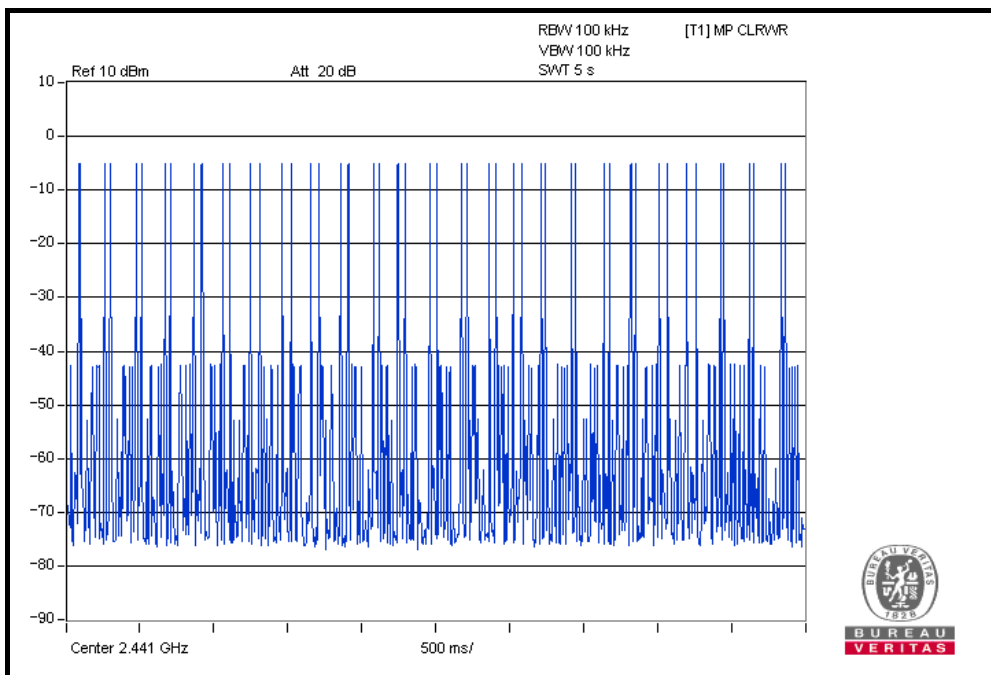



BUREAU VERITAS

Test Report No.: RF120924N006

DH3

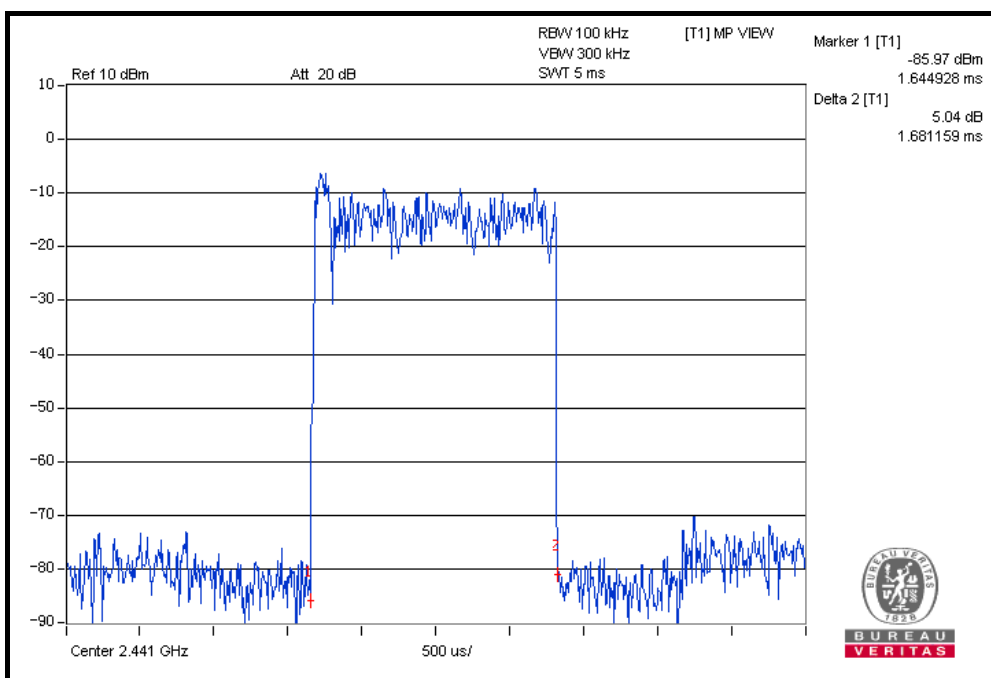
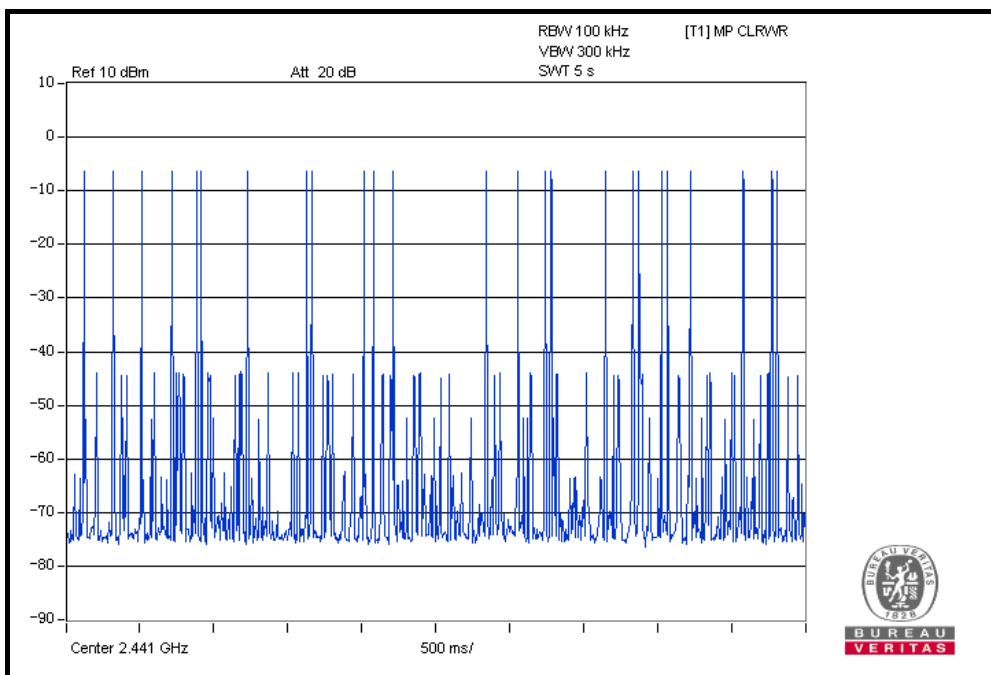

Bureau Veritas Shenzhen Co., Ltd.  
Dongguan Branch

No. 34, Chenwulu Section, Guantai Rd., Houjie  
Town, Dongguan City,  
Guangdong 523942, China

Tel: +86 769 8593 5656  
Fax: +86 769 8593 1080  
Email: [customerservice.dg@cn.bureauveritas.com](mailto:customerservice.dg@cn.bureauveritas.com)



BUREAU VERITAS

Test Report No.: RF120924N006

DH5

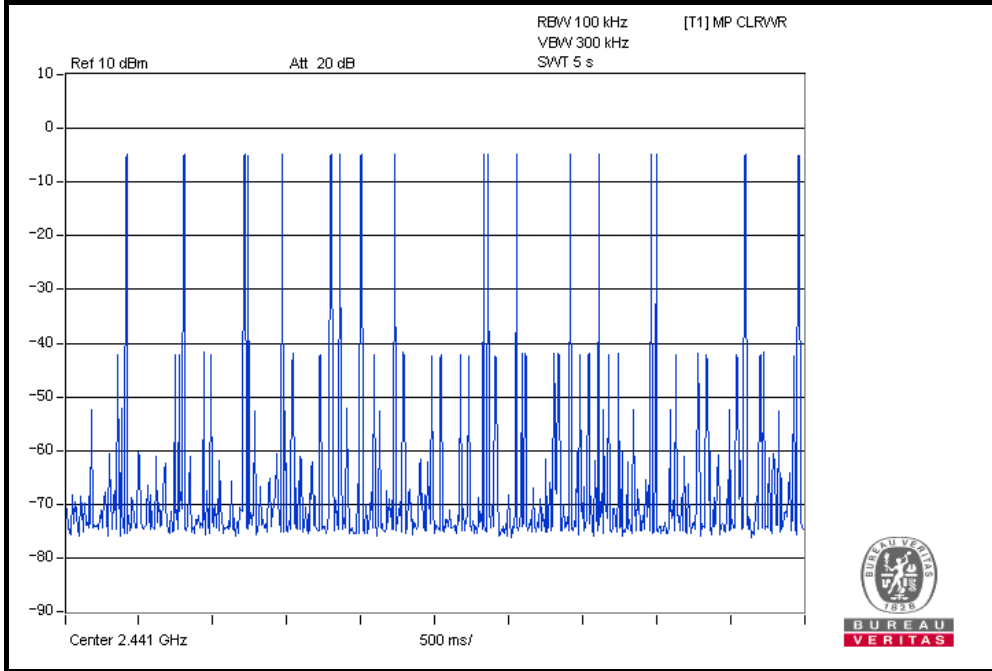

BUREAU VERITAS

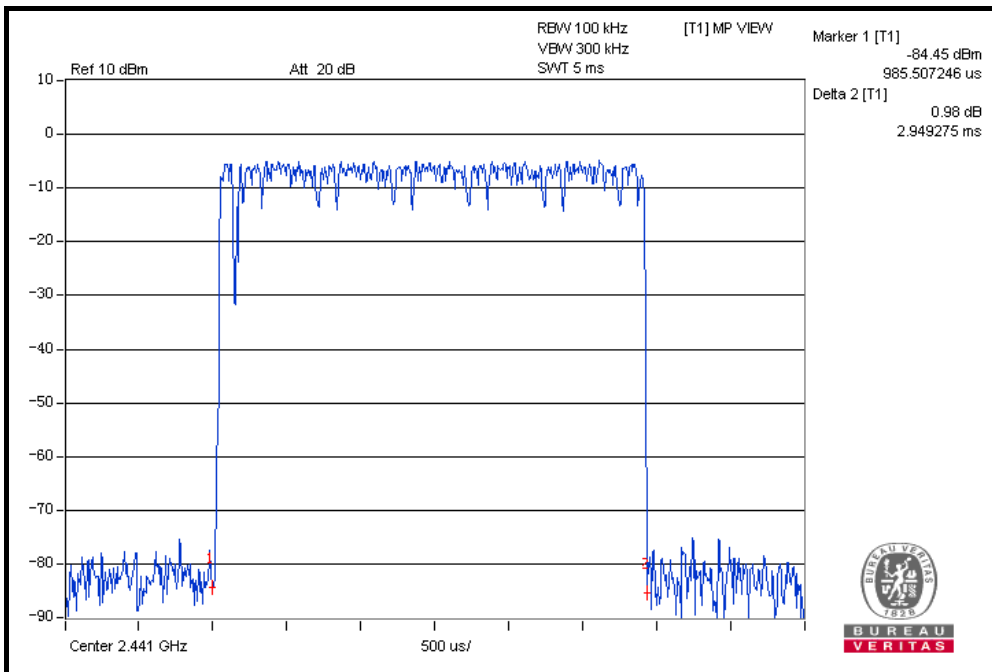

BUREAU VERITAS

Bureau Veritas Shenzhen Co., Ltd.  
Dongguan Branch

No. 34, Chenwulu Section, Guantai Rd., Houjie  
Town, Dongguan City,  
Guangdong 523942, China

Tel: +86 769 8593 5656  
Fax: +86 769 8593 1080  
Email: [customerservice.dg@cn.bureauveritas.com](mailto:customerservice.dg@cn.bureauveritas.com)



**8DPSK**

Mode	Number of transmission in a 31.6 (79Hopping*0.4)	Length of transmission time (msec)	Result (msec)	Limit (msec)
DH1	51 (times / 5 sec) * 6.32 = 322.32 times	0.457	147.30	400
DH3	24 (times / 5 sec) * 6.32 = 151.68 times	1.71	259.37	400
DH5	16 (times / 5 sec) * 6.32 = 101.12 times	2.95	298.30	400

**NOTE:** Test plots of the transmitting time slot are shown on next 3 pages.





BUREAU VERITAS

Test Report No.: RF120924N006

DH1

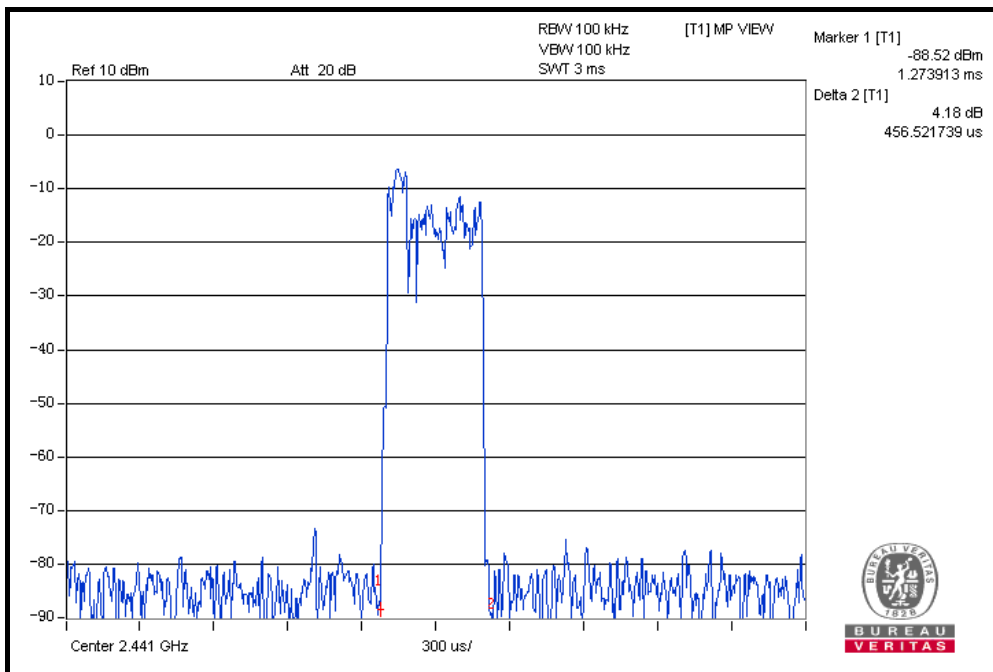
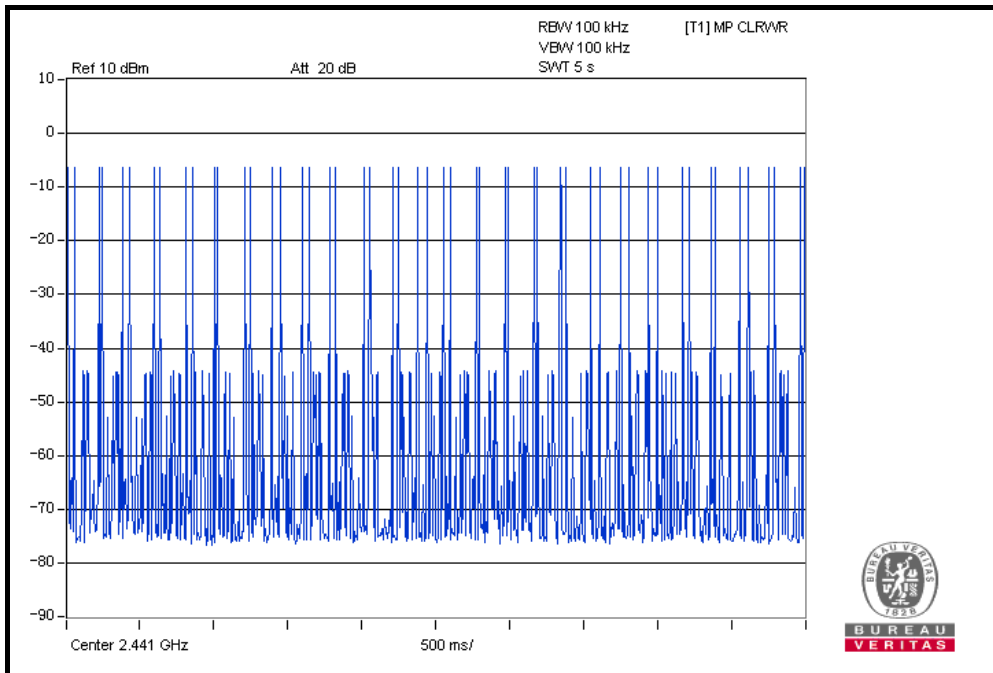



BUREAU VERITAS

Test Report No.: RF120924N006

DH3

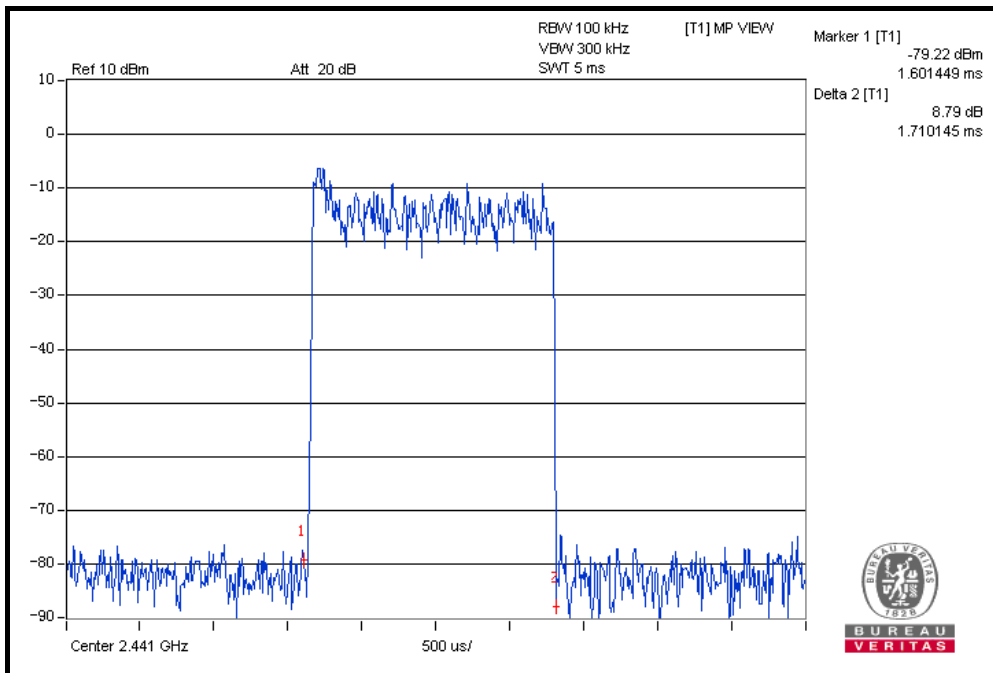
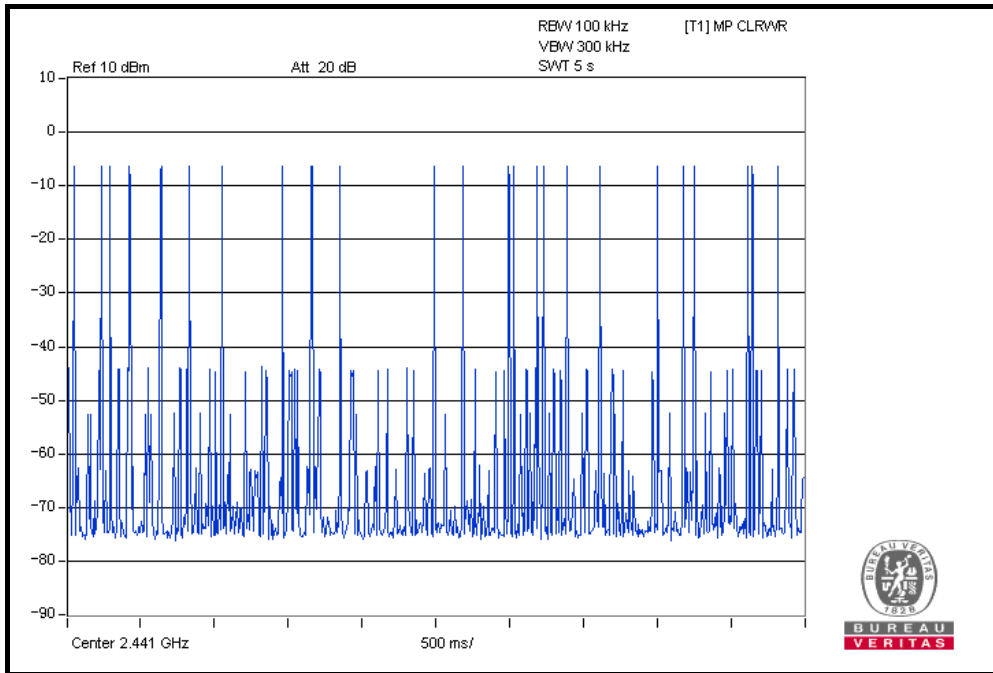

Bureau Veritas Shenzhen Co., Ltd.  
Dongguan Branch

No. 34, Chenwulu Section, Guantai Rd., Houjie  
Town, Dongguan City,  
Guangdong 523942, China

Tel: +86 769 8593 5656  
Fax: +86 769 8593 1080  
Email: [customerservice.dg@cn.bureauveritas.com](mailto:customerservice.dg@cn.bureauveritas.com)



BUREAU VERITAS

Test Report No.: RF120924N006

DH5

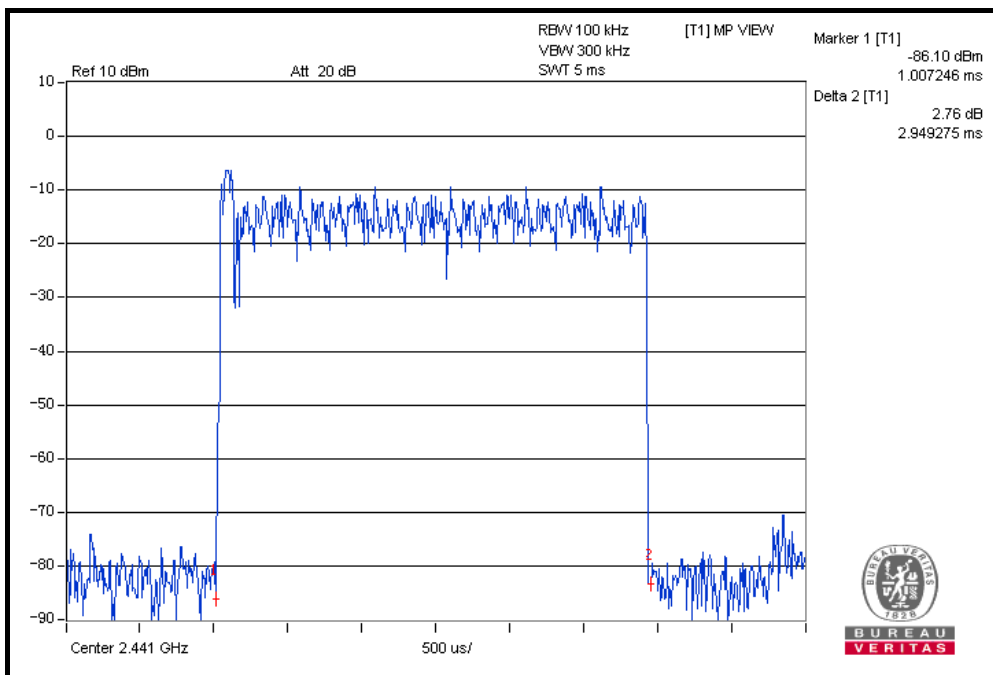
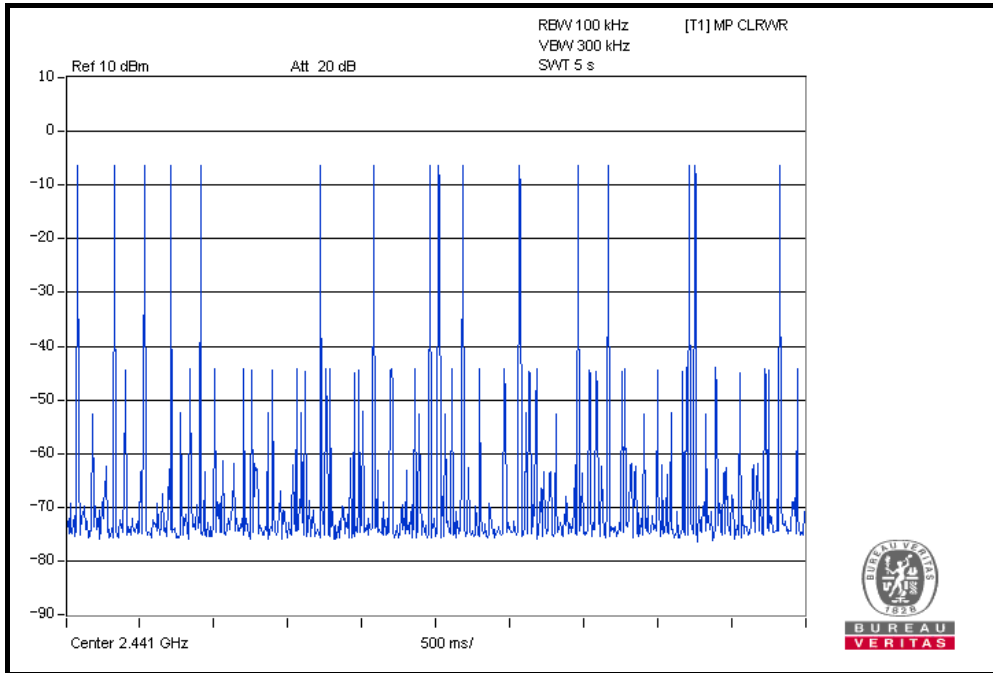



## 4.5. CHANNEL BANDWIDTH

### 4.5.1 LIMITS OF CHANNEL BANDWIDTH

For frequency hopping system operating in the 2400-2483.5MHz, If the 20dB bandwidth of hopping channel is greater than 25kHz, two-thirds 20dB bandwidth of hopping channel shall be a minimum limit for the hopping channel separation.

### 4.5.2 TEST SETUP

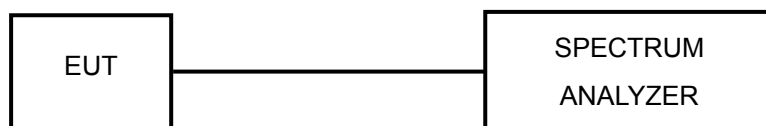

### 4.5.3 TEST INSTRUMENTS

Refer to section 4.1.2 to get information of above instrument.

### 4.5.4 TEST PROCEDURE

- a. Check the calibration of the measuring instrument using either an internal calibrator or a known signal from an external generator.
- b. Turn on the EUT and connect it to measurement instrument. Then set it to any one convenient frequency within its operating range. Set a reference level on the measuring instrument equal to the highest peak value.
- c. Measure the frequency difference of two frequencies that were attenuated 20dB from the reference level. Record the frequency difference as the emission bandwidth.
- d. Repeat above procedures until all frequencies measured were complete.



### 4.5.5 DEVIATION FROM TEST STANDARD

No deviation.

### 4.5.6 EUT OPERATING CONDITION

Same as item 4.2.6

### 4.5.7 TEST RESULTS

#### GFSK

CHANNEL	CHANNEL FREQUENCY (MHz)	20dB BANDWIDTH (MHz)
0	2402	0.94
39	2441	0.97
78	2480	0.97

#### CH 0

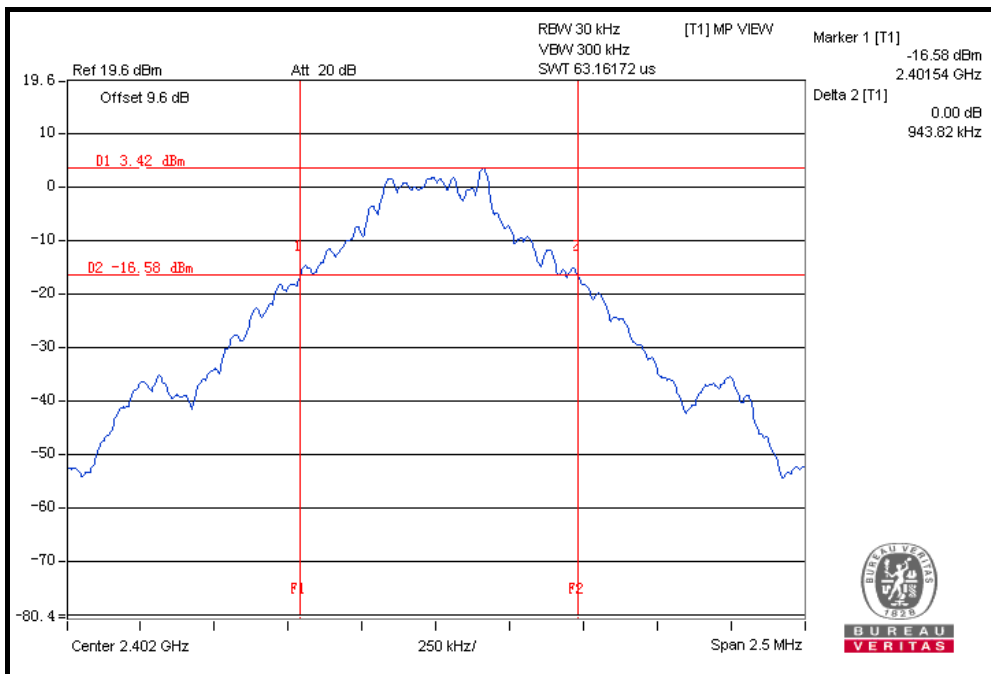



BUREAU VERITAS

Test Report No.: RF120924N006

CH 39

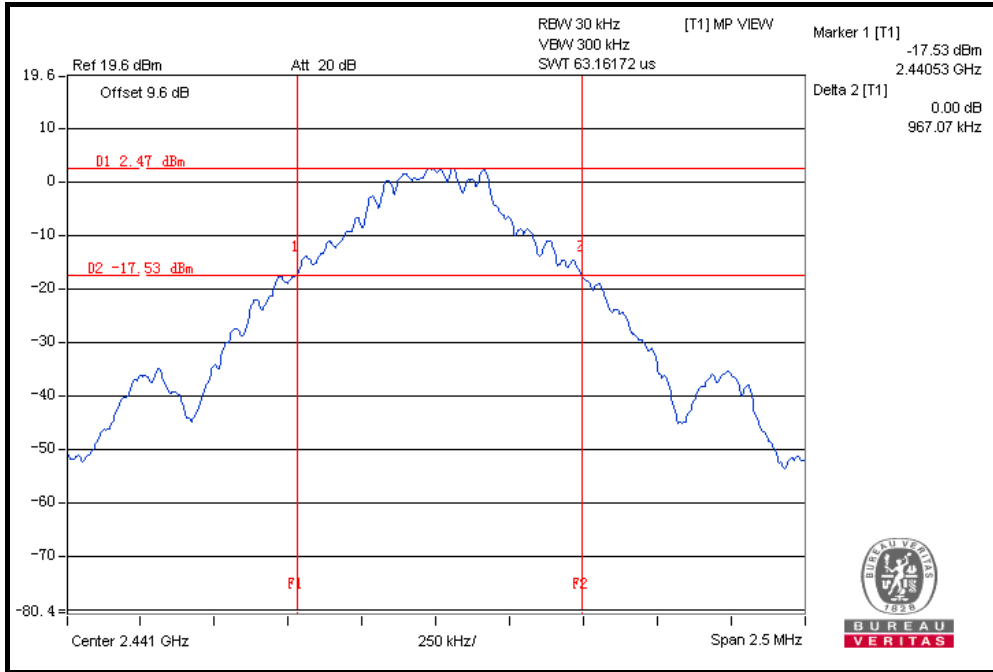

CH 78

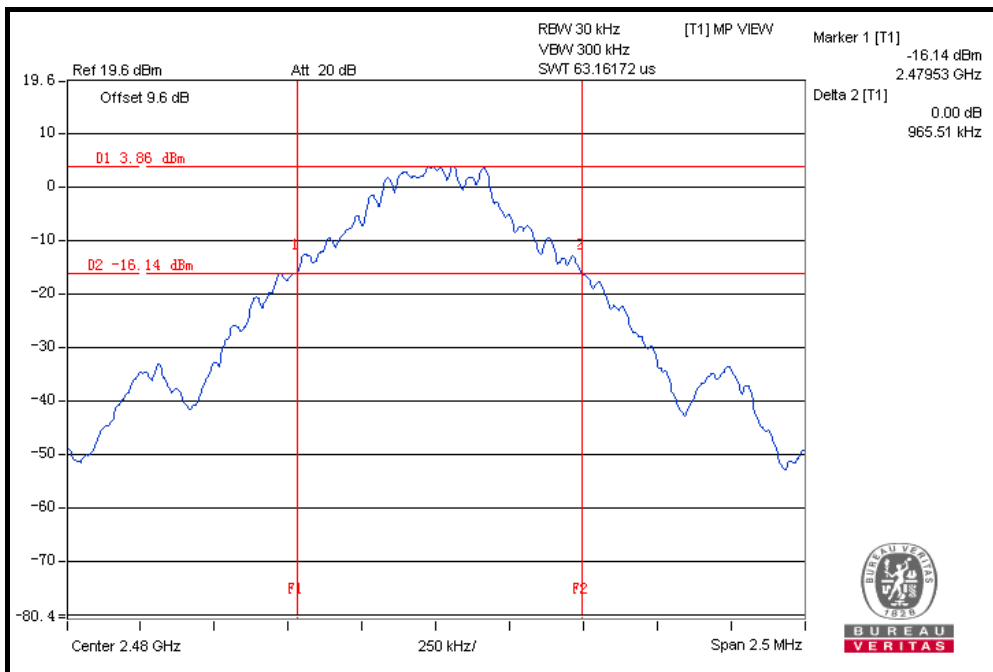

Bureau Veritas Shenzhen Co., Ltd.  
Dongguan Branch

No. 34, Chenwulu Section, Guantai Rd., Houjie  
Town, Dongguan City,  
Guangdong 523942, China

Tel: +86 769 8593 5656  
Fax: +86 769 8593 1080  
Email: [customerservice.dg@cn.bureauveritas.com](mailto:customerservice.dg@cn.bureauveritas.com)



BUREAU VERITAS

Test Report No.: RF120924N006

8DPSK

CHANNEL	CHANNEL FREQUENCY (MHz)	20dB BANDWIDTH (MHz)
0	2402	1.26
39	2441	1.29
78	2480	1.29

CH 00

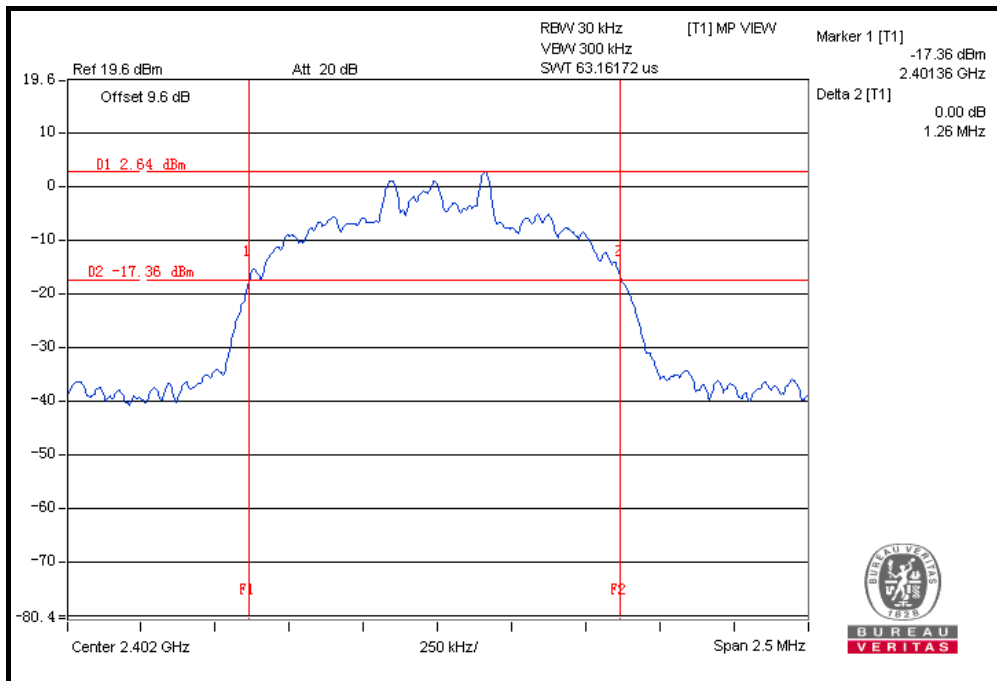



BUREAU VERITAS

Test Report No.: RF120924N006

CH 39

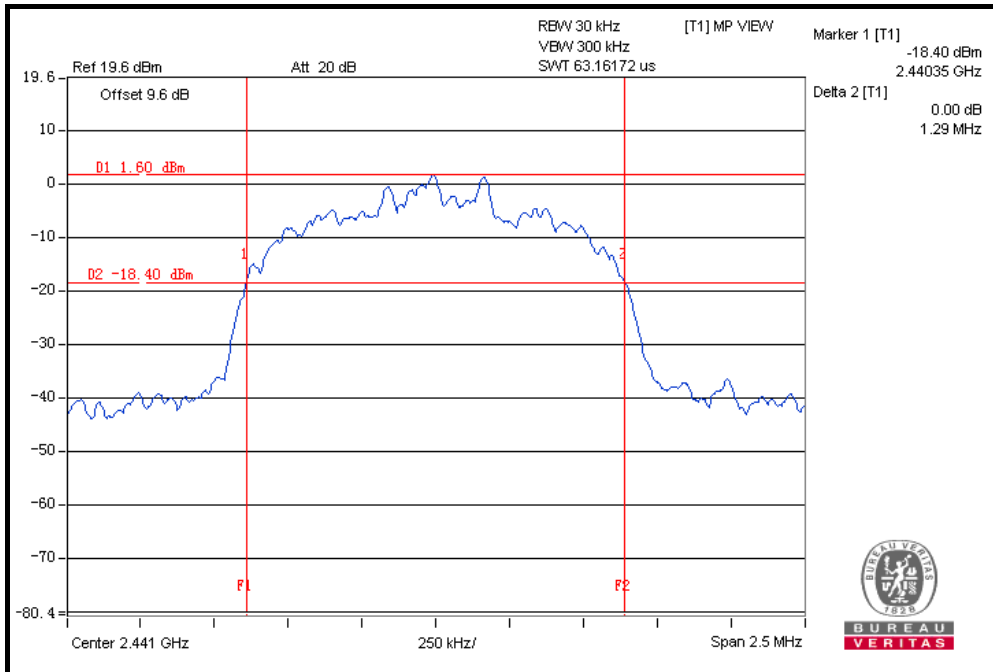

CH 78

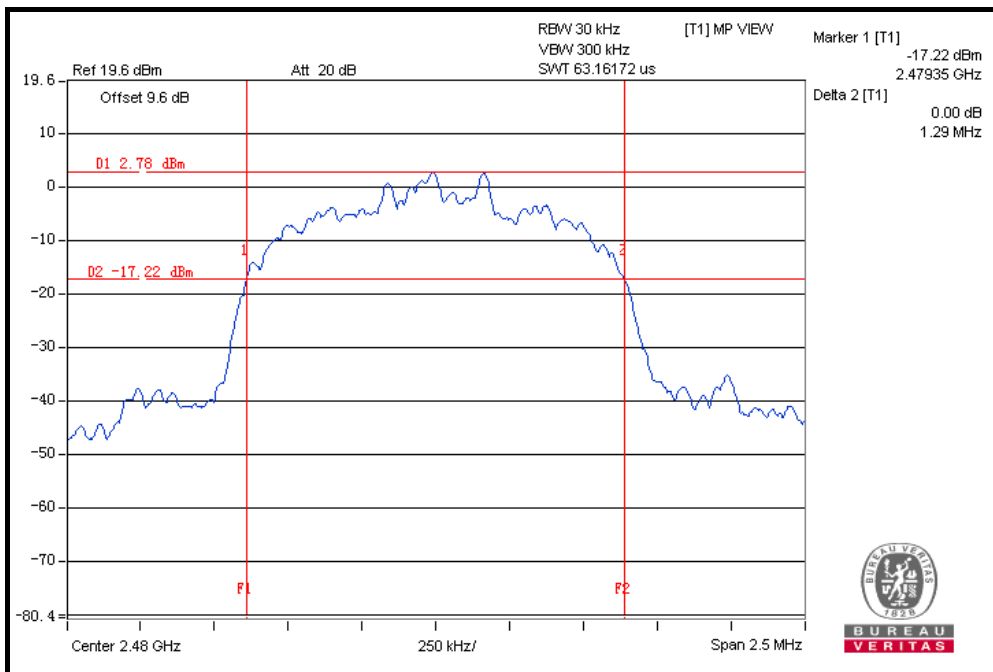

Bureau Veritas Shenzhen Co., Ltd.  
Dongguan Branch

No. 34, Chenwulu Section, Guantai Rd., Houjie  
Town, Dongguan City,  
Guangdong 523942, China

Tel: +86 769 8593 5656  
Fax: +86 769 8593 1080  
Email: [customerservice.dg@cn.bureauveritas.com](mailto:customerservice.dg@cn.bureauveritas.com)





## 4.6. HOPPING CHANNEL SEPARATION

### 4.6.1. LIMIT OF HOPPING CHANNEL SEPARATION

At least 25kHz or two-third of 20dB hopping channel bandwidth (whichever is greater).

### 4.6.2. TEST SETUP

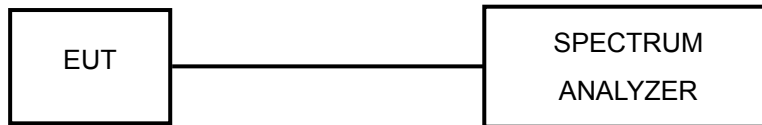

### 4.6.3. TEST INSTRUMENTS

Refer to section 4.1.2 to get information of above instrument.

### 4.6.4. TEST PROCEDURES

1. Check the calibration of the measuring instrument using either an internal calibrator or a known signal from an external generator.
2. Turn on the EUT and connect it to measurement instrument. Then set it to any one convenient frequency within its operating range.
3. By using the MaxHold function record the separation of two adjacent channels.
4. Measure the frequency difference of these two adjacent channels by SA MARK function. And then plot the result on SA screen.
5. Repeat above procedures until all frequencies measured were complete.

### 4.6.5. DEVIATION FROM TEST STANDARD

No deviation.



#### 4.6.6. TEST RESULTS

##### GFSK

CHANNEL	FREQUENCY (MHz)	ADJACENT CHANNEL SEPARATION (MHz)	20dB BANDWIDTH (MHz)	MINIMUM LIMIT (MHz)	PASS / FAIL
0	2402	1.01	0.94	0.63	PASS
39	2441	1.01	0.97	0.65	PASS
78	2480	1.01	0.97	0.65	PASS

##### 8DPSK

CHANNEL	FREQUENCY (MHz)	ADJACENT CHANNEL SEPARATION (MHz)	20dB BANDWIDTH (MHz)	MINIMUM LIMIT (MHz)	PASS / FAIL
0	2402	1.01	1.26	0.84	PASS
39	2441	1.01	1.29	0.86	PASS
78	2480	1.00	1.29	0.86	PASS

**NOTE:** The minimum limit is two-third 20dB bandwidth.



BUREAU VERITAS

Test Report No.: RF120924N006

### GFSK

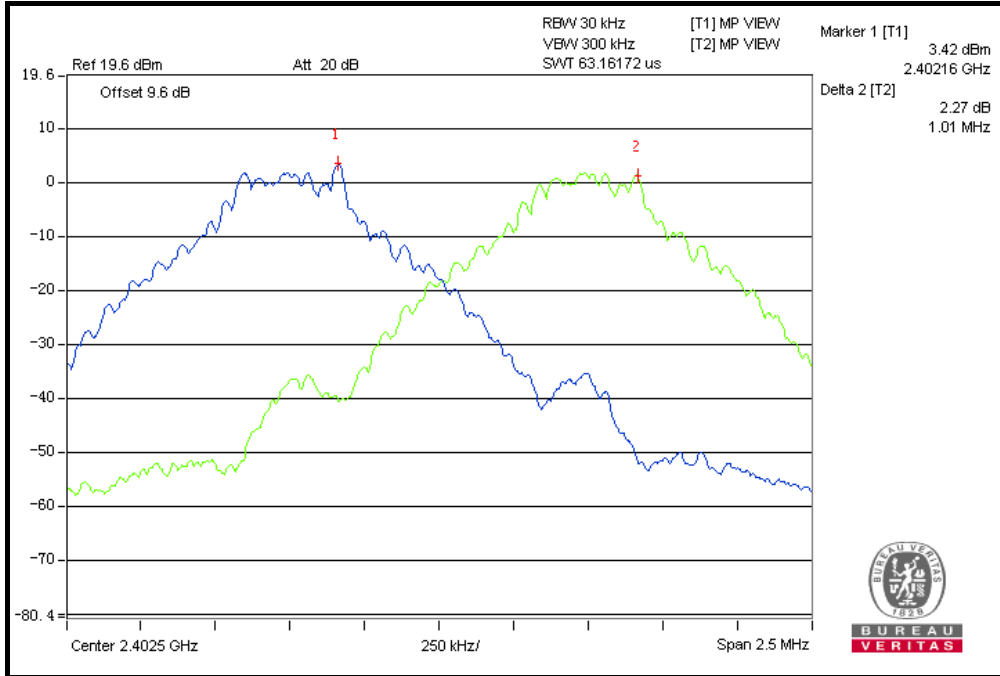

### 8DPSK

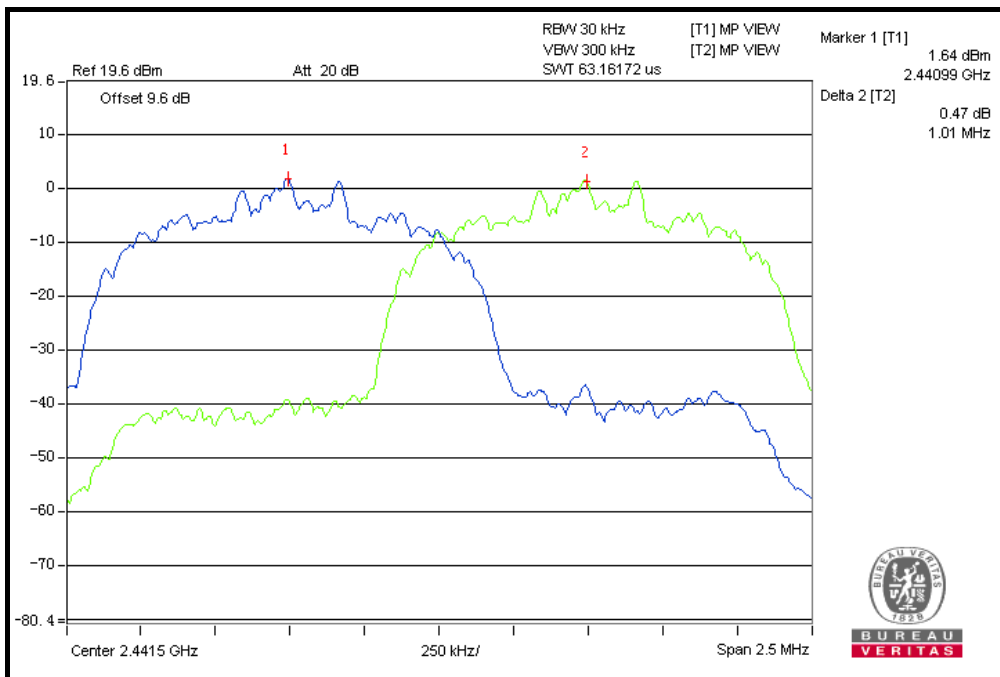

Bureau Veritas Shenzhen Co., Ltd.  
Dongguan Branch

No. 34, Chenwulu Section, Guantai Rd., Houjie  
Town, Dongguan City,  
Guangdong 523942, China

Tel: +86 769 8593 5656  
Fax: +86 769 8593 1080  
Email: [customerservice.dg@cn.bureauveritas.com](mailto:customerservice.dg@cn.bureauveritas.com)



## 4.7. MAXIMUM OUTPUT POWER

### 4.7.1 LIMITS OF MAXIMUM OUTPUT POWER MEASUREMENT

The Maximum Output Power Measurement is 125mW.

### 4.7.2 TEST SETUP

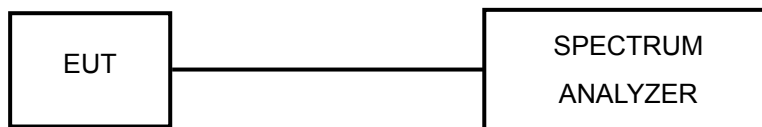

### 4.7.3 TEST INSTRUMENTS

Refer to section 4.1.2 to get information of above instrument.

### 4.7.4 TEST PROCEDURES

- a. Check the calibration of the measuring instrument using either an internal calibrator or a known signal from an external generator.
- b. Turn on the EUT and connect it to measurement instrument. Then set it to any one convenient frequency within its operating range. Set a reference level on the measuring instrument equal to the highest peak value.
- c. The center frequency of the spectrum analyzer is set to the fundamental frequency and using 3MHz RBW and 10 MHz VBW.
- d. Measure the captured power within the band and recording the plot.
- e. Repeat above procedures until all frequencies required were complete.



**BUREAU  
VERITAS**

Test Report No.: RF120924N006

#### 4.7.5 DEVIATION FROM TEST STANDARD

No deviation.

#### 4.7.6 EUT OPERATING CONDITION

Same as item 4.1.6.

#### 4.7.7 TEST RESULTS

##### GFSK

CHANNEL	CHANNEL FREQUENCY (MHz)	POWER OUTPUT (dBm)	POWER OUTPUT (mW)	POWER LIMIT (mW)	PASS/FAIL
0	2402	4.62	2.98	125	PASS
39	2441	5.48	3.53	125	PASS
78	2480	6.83	4.82	125	PASS

##### CH 78

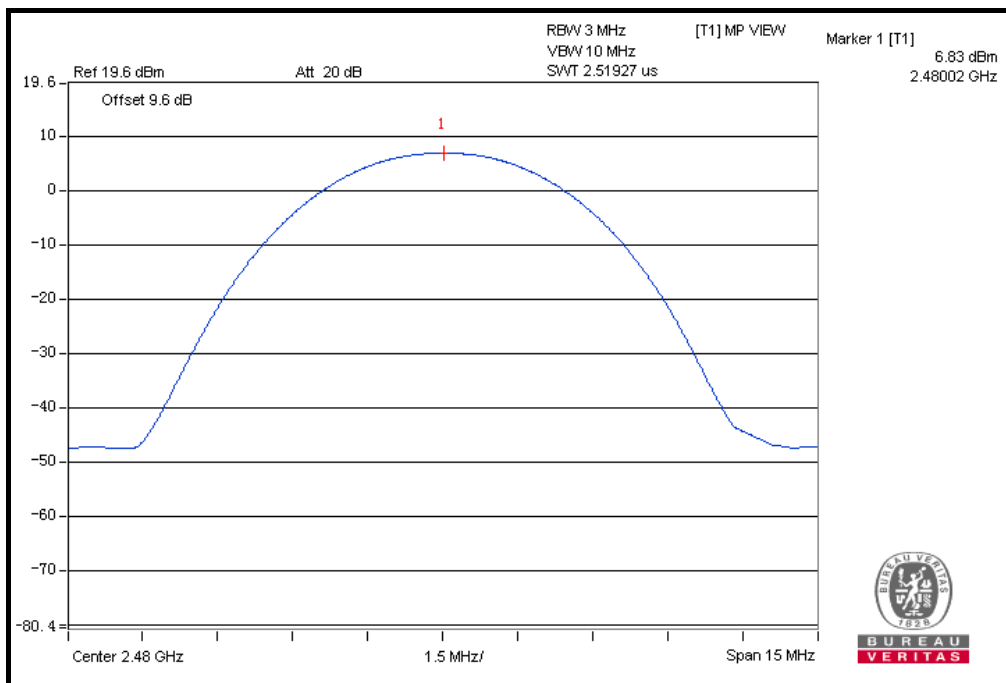



BUREAU VERITAS

Test Report No.: RF120924N006

### 8DPSK

CHANNEL	CHANNEL FREQUENCY (MHz)	POWER OUTPUT (dBm)	POWER OUTPUT (mW)	POWER LIMIT (mW)	PASS/FAIL
0	2402	4.61	2.89	125	PASS
39	2441	5.44	3.50	125	PASS
78	2480	6.84	4.83	125	PASS

### CH 78

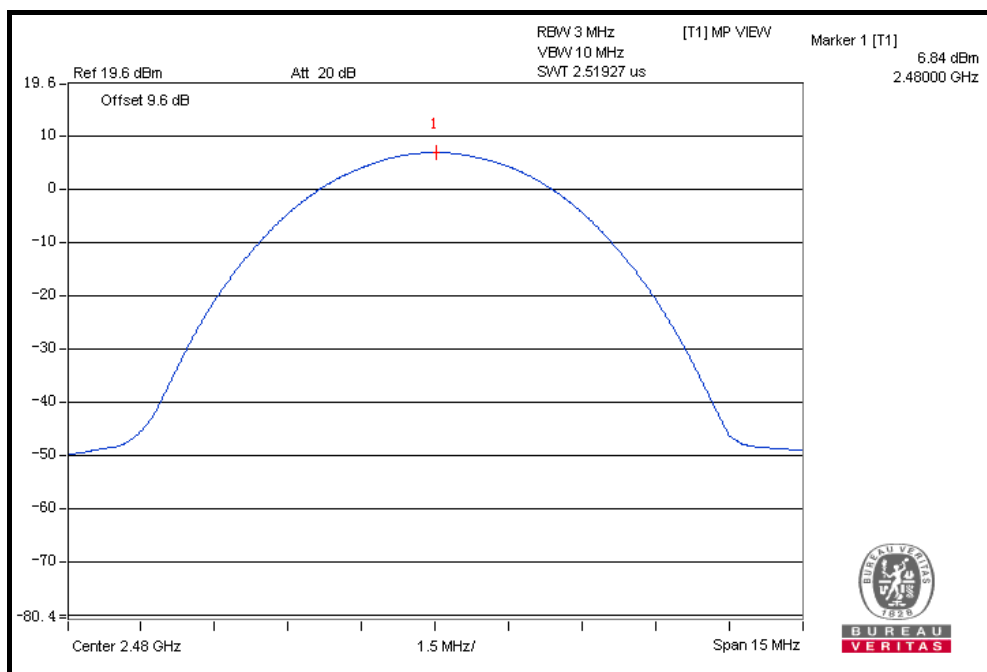



## 4.8. BAND EDGES MEASUREMENT

### 4.8.1 LIMITS OF BAND EDGES MEASUREMENT

Below -20dB of the highest emission level of operating band (in 100KHz RBW).

### 4.8.2 TEST INSTRUMENTS

Refer to section 4.1.2 to get information of above instrument.

### 4.8.3 TEST PROCEDURE

The transmitter output was connected to the spectrum analyzer via a low lose cable. Set both RBW and VBW of spectrum analyzer to 100 kHz with suitable frequency span including 100 MHz bandwidth from band edge. The band edges was measured and recorded.

### 4.8.4 DEVIATION FROM TEST STANDARD

No deviation.

### 4.8.5 EUT OPERATING CONDITION

Same as item 4.2.6



BUREAU VERITAS

Test Report No.: RF120924N006

### 4.8.6 TEST RESULTS

The spectrum plots are attached on the following images., D1 line indicates the 20dB offset below D1.

#### GFSK CH0

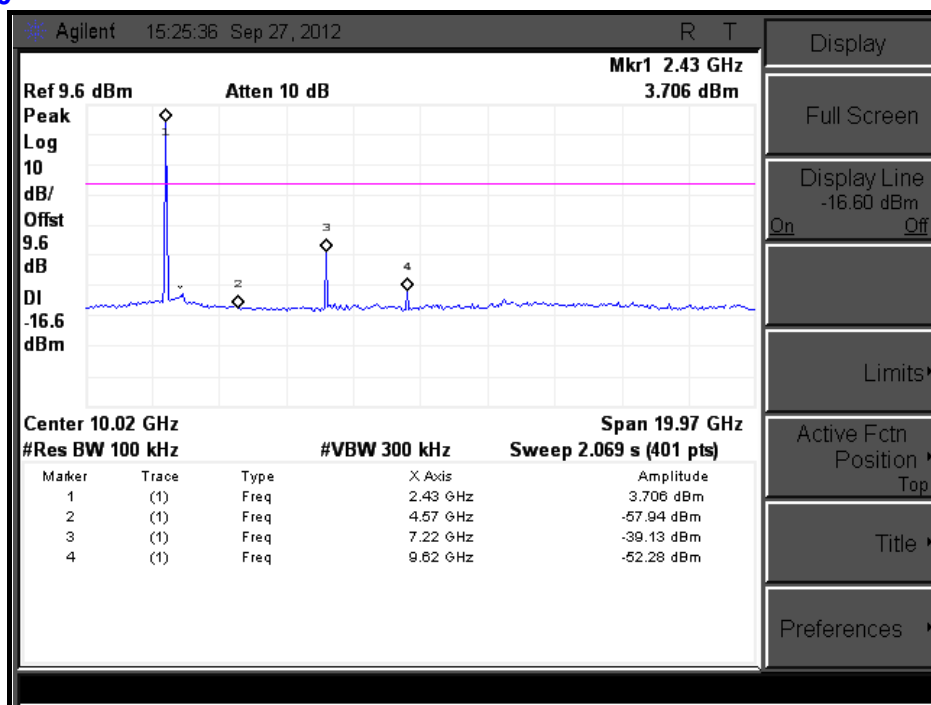





BUREAU VERITAS

Test Report No.: RF120924N006

### GFSK CH39

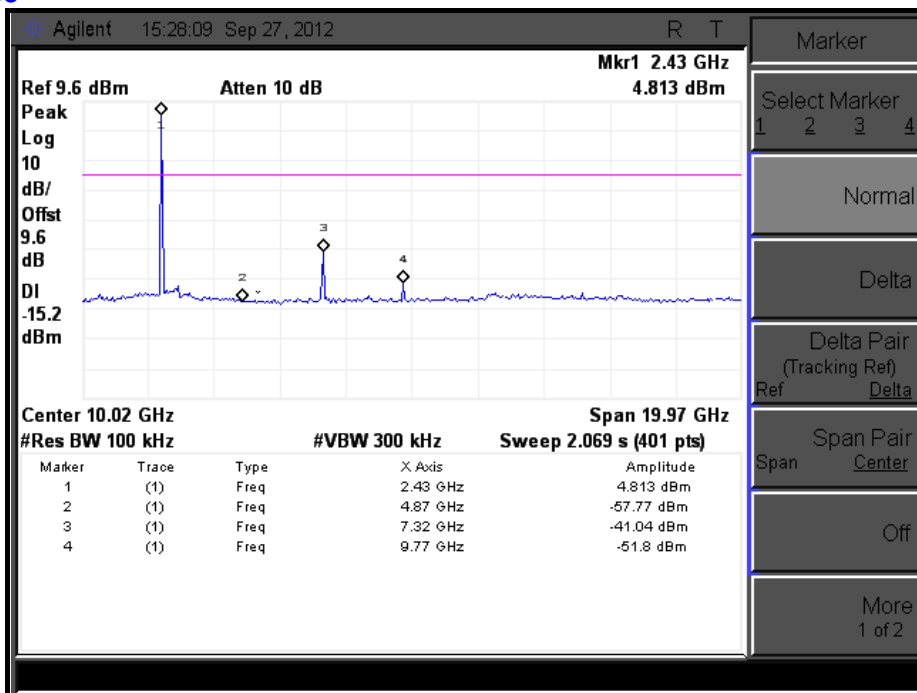

### GFSK CH78

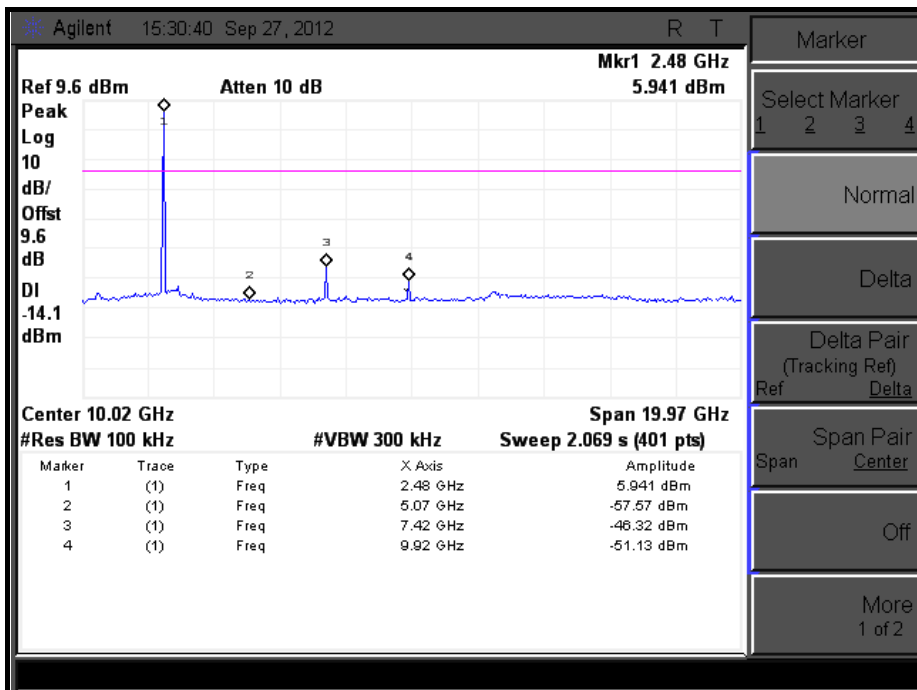



BUREAU VERITAS

Test Report No.: RF120924N006

### 8DPSK CH0

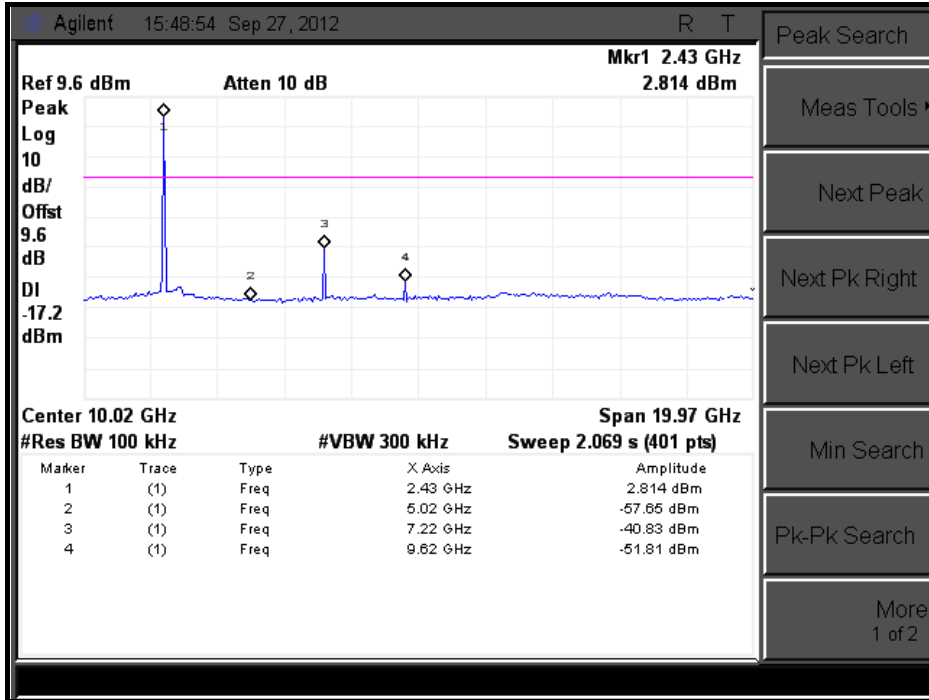

### 8DPSK CH39

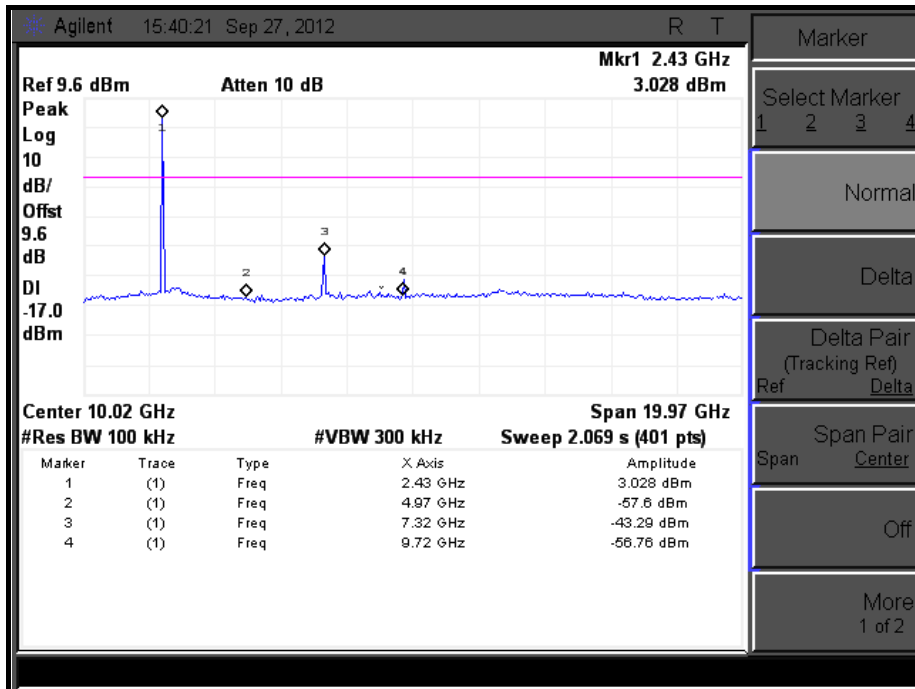



BUREAU VERITAS

Test Report No.: RF120924N006

### 8DPSK CH78

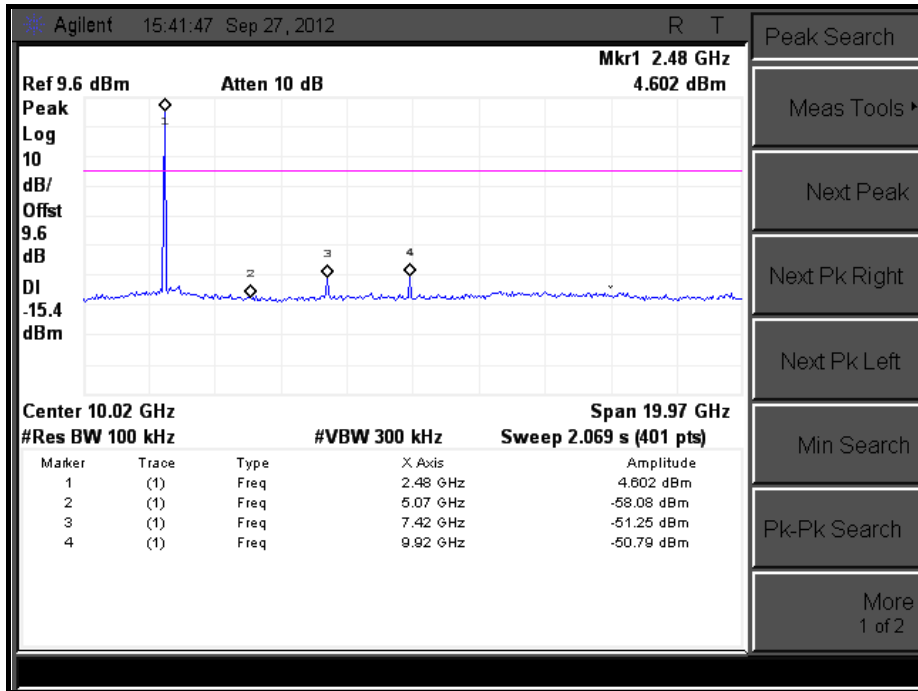



**BUREAU  
VERITAS**

Test Report No.: RF120924N006

## 5. PHOTOGRAPHS OF THE TEST CONFIGURATION

Please refer to the attached file (Test Setup Photo).



**BUREAU  
VERITAS**

Test Report No.: RF120924N006

## 6. APPENDIX A - MODIFICATIONS RECORDERS FOR ENGINEERING CHANGES TO THE EUT BY THE LAB

No any modifications are made to the EUT by the lab during the test.

---END---